

521  
0<1

**A STUDY ON THE EFFECTS OF TWO IRRIGATION SYSTEMS AND  
THE REUSE OF DRAINAGE WATER ON CORN AND SUNFLOWER  
YIELD**

By

ADEL MOHAMAD HELAL EL-METWALLY

*B. Sc. In Agric. (Agric. Eng.), Faculty of Agric.,*

Alexandria University, 1993

Thesis

*Submitted to the Graduate division in Partial Fulfilment  
of the Requirements for the Degree of*

MASTER OF SCIENCE

IN

AGRICULTURAL MECHANIZATION

DEPARTMENT OF AGRICULTURAL MECHANIZATION

Faculty of Agriculture,

Kafr El-Sheikh,

Tanta University.

1999

# Approval Sheet

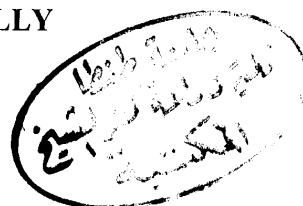
## ***REUSE OF DRAINAGE WATER WITH DIFFERENT IRRIGATION SYSTEMS***

**A STUDY ON THE EFFECTS OF TWO IRRIGATION SYSTEMS AND  
THE REUSE OF DRAINAGE WATER ON CORN  
AND SUNFLOWER YIELD**

By

**ADEL MOHAMAD HELAL EL-METWALLY**

Thesis for M.SC. Degree in  
Agricultural Mechanization



**Has been approved by:**

**Prof. Dr. Mohamed N. El-Awady**.....*M. N. El-Awady*.....  
Professor of Ag. Eng., Ag. Mech. Dept.,  
Faculty of Agric., Ain Shams University.

**Prof. Dr. Metwalli M. Mohamed**.....*M. Metwalli*.....  
Professor of Ag. Eng., and head of Ag. Mech. Dept.,  
Faculty of Agric., Kafr El-Sheikh, Tanta University.

**Prof. Dr. Mamdouh A. Helmy**.....*M. Helmy*.....  
Professor of Ag. Eng., Ag. Mech. Dept.,  
Faculty of Agric., Kafr El-Sheikh, Tanta University.

**Dr. Samir M. Gomaa**.....*S. M. Gomaa*.....  
Associate professor of Ag. Eng., Ag. Mech. Dept.,  
Faculty of Agric., Kafr El-Sheikh, Tanta University.

Date: 28 / 6 / 1999

## ***SUPERVISION COMMITTEE***

Prof . Dr.

**MAMDOUH ABBAS HELMY**

Prof. of Agricultural Engineering,

Faculty of Agriculture,

Kafr El-Sheikh, Tanta University.

***Dr. SAMIR MAHMOUD GOMAA***

Associate Prof. of Agricultural Engineering,

Faculty of Agriculture,

Kafr El-Sheikh, Tanta University.

***Dr. EL-SAIED MOHAMAD KHALIFA***

Lecturer of Agricultural Engineering,

Faculty of Agriculture,

Kafr El-Sheikh, Tanta University.

## **ACKNOWLEDGEMENT**

The author wishes to express his deep gratitude and sincere appreciation to Prof. Dr. **Mamdouh Abbas Helmy**, Professor of Agricultural Engineering Agric. Mech. Dept., Faculty of Agriculture, Kafr El Sheikh, Tanta University and Dr. **Samir Mahmoud Gomaa**, Associate Professor of Agricultural Engineering, Agric. Mech. Dept., Faculty of Agriculture, Kafr El Sheikh, Tanta University and Dr. **El Saeid Mohamed Khalifa**, lecturer of Agricultural Engineering, Agric. Mech. Dept., Faculty of Agriculture, Kafr El Sheikh, Tanta University for their supervision , helpful advises and constructive criticisms.

Dr. **Tarek Zaki Hassan**, lecturer of Agricultural Engineering, Agric. Mech. Dept., Faculty of Agriculture, Tanta, Tanta University for his , helpful advises and constructive criticisms.

Thanks are also, presented to Dr. **M. Attef**, Dr. **A. Merghany**, Mr. **A. Khamees** and Mr. **E. Ghalap** and all members of soils department, Agricultural research center for their helps and provided facilities during the work.

# CONTENTS

1. INTRODUCTION.....	1
2. REVIEW OF LITERATURE.....	3
2.1. Sources of irrigation water in Egypt.....	3
2.2. Reuse of drainage water for irrigation.....	3
2.3. Effect of irrigation water salinity, applied water volume and irrigation system on salt content and distribution in the soil.....	7
2.4. Effect of irrigation water salinity, applied water volume and irrigation system on soil moisture content and its distribution.....	11
2.5. Effect of irrigation water salinity, applied water volume and irrigation system on vegetative growth.....	13
2.6. Effect of irrigation water salinity, applied water volume and irrigation system on crop yield.....	15
2.7. Effect of irrigation water salinity, applied water volume and irrigation system on water use efficiency (WUE).....	22
3. MATERIALS AND METHODS.....	25
4. RESULTS AND DISCUSSION .....	35
4.1. Effect of irrigation water salinity, applied water volume and irrigation system on salt content and distribution.....	35
4.2. Effect of irrigation water salinity, applied water volume and irrigation system on soil moisture content and distribution.....	39
4.3. Effect of irrigation water salinity, applied water volume and irrigation system on vegetative growth.....	43
4.4. Effect of irrigation water salinity, applied water volume and irrigation system on crop yield.....	54
4.5. Effect of irrigation water salinity, applied water volume and irrigation system on water use efficiency (WUE).....	59
5. SUMMARY AND CONCLUSION.....	66

6. REFERENCES.....	71
7. APPENDIX.....	81
8. ARABIC SUMMARY .....	

## INTRODUCTION

The River Nile is being the main source of the water in Egypt. It is truly described to be its pulsing nerve and cornerstone of any development projects. Egypt annual quota of the Nile water is 55.5 billion m<sup>3</sup> (El-Wakeel and ElMowelhi, 1993) being used to the different water demands. When we are looking to the future , the quantity of Nile water is not sufficient to the requirements of drinking purposes , industrial development , horizontal expansion of Agriculture , and other purposes. Therefore, we must be looking for another sources of water. The reuse of drainage water is already practiced on a large scale.

Egypt is one of the leading countries in the reuse of drainage water for irrigation. At present, an average of about 4.6 billion m<sup>3</sup> of drainage water is annually used for irrigation up to the year 2000. It has been planned to make use of about 7 billion m<sup>3</sup> (El-Wakeel and El-Mowelhi, 1993).

The farmers who suffer from shortage of fresh water, they readily used agricultural drainage water.

Most of drainage water about 12.5 billion m<sup>3</sup> (El-Wakeel and ElMowelhi, 1993) is thrown to the Mediterranean Sea and northern lakes and Suez canal. In fact, drainage water is generally saline composition and concentration differs from one location to another. Therefore, drainage water utilization in irrigation purposes should have some effective changes on irrigated soils such as physical properties and chemical properties. This effect depends on quantity and quality of used drainage water.

The objectives of the present research are to study the possibility of drainage water reuse with surface and drip irrigation systems and investigate its effect on growth both corn and sunflower crop.



## **2.REVIEW OF LITERATURE**

### **2.1.Sources of irrigation water in Egypt:**

The Egyptian water budget consists of the following items:

- 1-The country share of the river Nile water which is fixed according to international agreement at 55.5 billion cubic meter.
- 2-Minor quantities of underground water exploited from the western and eastern desert reservoirs and reservoir underneath the Nile in the Upper Egypt.
- 3-Negligible amounts of rains that falls on the North East and North West coasts and on the Nile delta. About 80 percent of the total of previous quantities used for the irrigation.
- 4-Agricultural drainage waters which is due to land drainage.

(El-wakeel and El-Mowelhi, 1993) stated that an amount of about 4.6 billion cubic meter of drainage water is annually used for irrigation. Up to the year 2000. It has been planned to make use of about 7 billion cubic meter. Despite of the availability of legislation for water pollution control in Egypt, majority of drainage water courses receive untreated or insufficient treated wastes. These wastes which pollute our natural resources are serious today and may progressively become more serious in the year ahead.

### **2.2.Reuse of drainage water for irrigation:**

Ismail *et al.* (1978) reused the drainage water that come from the main drains in Fayuam. The study revealed that the water from drains is not suitable for irrigation without precaution. The water of El-Wady and Batn Ahreet drains has better quality than that of the other drains, because it does not cause alkalisation of the soils. This maybe due to their high calcium content.

El-Nahal *et al.* (1979) determined the possibility of using low water quality for irrigating cotton, grown on both the Nile valley and delta lands and the

recently reclaimed land in the desert fringe. They used two sources of water for irrigation, the first one was tap water and the other was drainage water. Their results indicated that the drainage water of most of the main drains in the Delta could be safely used for irrigating cotton plant, provided that adequate leaching.

**Balba and Atta (1981)** mentioned that the water quality of the main drains in El-Behaira governorate varies considerably according to the drained area. In order to utilize the water from these drains several specifications should be followed as the application of leaching requirement ( $LR_{EC}$  and  $LR_{SAR}$ ). At the same time the expected soil salinity ( $EC_e$ ) and the maximum allowable irrigation water salinity ( $EC_{iw}$ ), should be taken into consideration. They added that the blending water is a practice, which might be enable increased the amount of water and the irrigated area.

**Amer and Van der Zel (1983)** studied the quality of Egyptian drainage water for irrigation. They found that salinity of drainage water varied from one drain to another with average concentration ranging from 400 to 5000 ppm. The higher concentration being found in the areas subjected to upward seepage of saline ground water. The salinity has been generally fluctuated seasonally as to be high during the annual maintenance of the irrigation system in January and February when the irrigation canals being emptied for period of twenty days.

**El-Nahal *et al.* (1983)** reported that the water of both Bahr El-bakr and El-Wadi drains contained less than 1000 ppm salinity and their sodium adsorption ratio (SAR) values were low throughout the year, it may be used directly for irrigation. The total annual discharge of these two drains was estimated at about 0.6 billion cubic meters, which is sufficient to irrigate about 60000 feddans. They suggested that, the water of Bahr El-Bakr drain maybe used for irrigating part of

the Salhia plain. El-Wadi drainage water can be used for irrigating new land areas South of Ismailia canal.

**Shehata *et al.* (1983)** studied the possibility of reusing drainage water in El-Menya, El-Mansoura and El-Beheira governorates. They also showed that in all cases, the values of total soluble salts (TSS) and sodium adsorption ratio (SAR) indicate the possibility of using this drainage water in irrigation without any side effect.

**Zartman and Gichuru (1984)** stated that the use of poor-quality water for irrigation can have pernicious effects of sodium adsorption ratio (SAR), soil salinity ( $EC_e$ ) and potassium (K). To prevent or curtail further problems, it may be necessary to follow: (1) the following points to irrigate more frequently to maintain a greater soil water quantity and limit osmotic potential, (2) to alternate irrigation with blow down water (BDW) and better quality water to dilute the salt concentration, (3) to use extra water to satisfy the leaching requirement, or (4) to improve the methods of irrigation to get better control of water flow and distribution. Water application method and management practices are likely the keys for successful irrigation.

**Rolston *et al.* (1986)** indicated that salt tolerant crops could be grown successfully under irrigation with either saline drainage water or a combination of saline and good-quality waters. But the long-term suitability of soils for cropping under these conditions depends on their water and air permeability and on soil structural properties which control the friability of seed beds.

**Ayars *et al.* (1988)** studied the management of saline irrigation water in arid areas with shallow ground water. They found that it is possible to use saline  $EC$  equal to 8 ds/m water salinity in conjunction with non saline water to grow salt

tolerant crops. Nearly 70 percent of the irrigation water required for growing sugar beet and cotton was saline drainage water.

**Rhoades *et al.* (1988)** stated that saline water could be successfully substituted for good water to irrigate certain crops in rotation when they are in a salt-tolerant growth stage. With the good water used for the other irrigation.

**Ayers *et al.* (1986)** used drip irrigating cotton with saline drainage water. They found that cotton was trickle irrigated with 8.5 ds/m saline water on saline soil in the presence of saline water table. The yields were equal to a well-watered check plot which was irrigated with non-saline water.

**El-Leithi *et al.* (1990)** studied the effect of drainage water reuse on the yield of wheat plants. They used three types of water for irrigation Nile water, mixed water (50% Nile water + 50% drainage water), and drainage water. Their results indicated that the yield of wheat grains was significantly decreased as drainage water was used. Mixed drainage water can be used in irrigation purposes for short time; but its continuous use may lead to accumulation of Zn and Cu in the soil to un-permissible levels.

**Abo-Soliman *et al.* (1992)** used drainage water in irrigation at north of Nile Delta, to study its effect on soil salinity and wheat production. His result showed that saline water having electrical conductivity equal to 3.2 ds/m with sodium adsorption ratio (SAR) of 7.5 could be use safely without inducing significant reduction in wheat production.

## **2.3.Effect of irrigation water salinity, applied water volume and irrigation system on salt content and distribution in the soil:**

### **2.3.1.Effect of irrigation water salinity on salt content and distribution:**

A salinity problem, exists if salt accumulates in the plant root zone to a concentration which causes a loss in yield. Yield reductions occur when the crop is no longer able to extract sufficient water from the saline soil solution.

**Omar and aziz (1982)** indicated that the electrical conductivity in solution of loamy had a significant increase as a result of salt concentration increase in the irrigation water.

**Subba-Rao et al. (1987)** reported that sandy soil irrigation with saline water having 3000 to 10000 ppm soluble salts resulted in a salt accumulation and the rate of this accumulation depended on the period of leaching and the amount of applied irrigation water

**Hamdy (1989)** reported that increasing the salinity of irrigation water caused a significant increase in salt content in the upper layer of soil profile.

**Aly (1990)** stated that the values of electrical conductivity (EC) and total dissolved solids (TDS) in soil extract were gradually increased with use of saline water for irrigation along soil profile up to 200cm depth.

**Kandil (1990)** revealed that using low water quality either from drains only or as a mixture between the canals and salinity drains resulted an apparent increase in soil salinity especially in the chloride and sodium forms. This increase was more clear in the surface layers.

**Sharma et al. (1990)** evaluated the effect of irrigation with drainage water of four different salinity levels ( $EC_{iw}$  of 6,9,12, and 27 ds/m) on soil salinity build up and growth and yield of wheat in a sandy loam soil. They found that application

of drainage water with increasing levels of salinity increased the soil salinity at all levels sampled to a depth of 90cm. They also suggested that saline drainage water having salinity up to 9 ds/m can safely be reused for irrigation of wheat in sandy loam soils under the provision of subsurface drainage system.

**Abo-soliman *et al.* (1992)** used drainage water in irrigation at north of Nile Delta and its effect on soil salinity. The results revealed that using drainage water for irrigation increased the total storage of total soluble salts (TSS) and salt components in soil, while using fresh water exerted the opposite trend. Using drainage water for irrigation in the first months and followed by fresh water decreased total storage of TSS and salt components values in soil. On the other hand, it could be concluded that using saline water having EC of 1.6 ds/m with SAR of 7.5 does not accumulate salts in soil.

**Mostafa *et al.* (1992)** conducted an experiment in greenhouse by using clay, calcareous and loamy soils and irrigation solutions differing in their salt concentration, sodium adsorption ratio (SAR) value and Ca:Mg ratios with barley crop. Their results indicated that increasing irrigation water salinity up to 4000 ppm gradually and significantly increased soil salinity ( $EC_e$ ), chloride (Cl) and  $SO_4$  concentrations and slightly decreased soil pH and  $HCO_3$  content. This trend was more pronounced in clay soil comparing to the other types.

**El-Shewikh (1996)** reported that irrigation with lower water quality has a highly effect on soil salinity. Surface soil profile of 0-20 Cm, was highly affected more than subsurface soil profile of 20-40 Cm. Irrigation with drainage water has a highly affected more than another irrigation types. Also using low water quality treatments leads to increase chloride ions more than sulphate ions in soil solution.

**Amer *et al.* (1997)** evaluated the effects of five years of irrigation drainage water on soil salinity build-up and yield of cotton, rice and maize grown on

clayey soil. The results indicated that the continuous use of drainage water for irrigating different crops, caused an increase of soil salinity and yield reduction with the time, so a proper water management should be used to minimize the salinity hazard and maximize the crop yield.

### 2.3.2. Effect of irrigation system on salt content and its distribution in soil:

**Bernstein and Francois (1973)** studied the effect of irrigation system on salt content and distribution in the soil, he found that under drip irrigation system the salts accumulated at mid way between emitters and the edge of the wetted zone.

**Bucks et al. (1974)** reported that the salts under drip irrigation system were moved from 3 to 4 ft. away from emitters and appeared near soil surface and increased soil salinity up to 4 to 5 mmhos/cm. On the other hand, salt distribution under furrow system remained less than 2.5 mmhos/cm.

**Gerard (1974)** used irrigation water which having electrical conductivity equal to 1.25 mmhos/cm, in drip and furrow irrigation systems to irrigate sugar cane on different textured soil and its effect on soil properties. He found that soil salinity increased under drip irrigation, especially at the edge of the wetted zone. The soil salinity ( $EC_e$ ) at lower depth of fine textured soil ranged from 3.7 to 7.0 mmhos/cm, comparing with 0.7 to 1.7 mmhos/cm, in the same lower depths of medium textured soil.

**Bakr et al. (1979)** compared between drip, sprinkler and furrow irrigation systems on salt distribution in sandy loam soil cultivated with watermelon plant and the electrical conductivity of irrigation water ( $EC_{iw}$ ) equal to 0.98 to 1.04 mmhos/cm. They found that soil salinity decreased in wetted drip irrigated area and increased at the edges of the wetted area. Irregular salt distribution was observed in the sprinkler irrigated plots while were concentrated close to the plants and root zone in the furrow irrigated plots.

**Groot and Alexander (1979)** found a very high salt concentration in the various soil layers of the drip treatment, while the flood irrigation treatment had a lower concentration of salts.

**West *et al.* (1979)** observed that the lowest concentration of salts occurred immediately below the emitters, while the highest one was found at the edge of wetting pattern. They added different amounts of sodium chloride to irrigation water in order to change the concentrations of salt in irrigation water.

**Kumar and Sivanappan (1980)** studied salt distribution with five levels of water salinity and three types of emitters. Their results showed that the soil salinity around the root zone of plants was maintained at the lowest level and salt was pushed to the other prephery of the moist zones.

**Kumar *et al.* (1985)** measured the soil salinity terms of saturated electrical conductivity ( $EC_e$ ) along and across the lateral profile. They used three treatments daily irrigation  $T_1$ , one-day interval  $T_2$ , and two days interval  $T_3$ . It was obvious that trickle irrigation system managed to minimize the soil salinity near the plants, which were sown by the side of emitters in all treatments. The daily irrigated treatment resulted a minimize soil salinity of about 1.4 mmhos/cm followed by one day interval of about 2.1 mmhos/cm and two days interval of about 2.3 mmhos/cm. they added that the reason maybe due to the continuous movement of salt away from the emitters in daily irrigation and this frequent irrigation prevented appreciable concentration of salts in between two irrigations.

**Hamdy (1992)** mentioned that the analysis of salt accumulation through the soil profile at different distances from source showed the movement of salt further from the water sources under both drip and furrow irrigation systems. Under drip system, the variations between different points of soil profile were more pronounced as compared to the furrow one.



Mohamed (1995) stated that the electrical conductivity of soil ( $EC_e$ ) remarkably increased by increasing the salinity of irrigation water up to 4000 ppm. Regardless of the other conditioning treatments. The increase takes the vertical and horizontal directions under drip irrigation systems and vertically only under furrow irrigation systems.

### **2.3.3. Effect of applied water volume on salt content and distribution:**

El-Ebaby (1979) reported that under sprinkler irrigation salt content in soil profile was mainly affected by the amount of water added, components of soil and type of irrigation water. Thus, the salt concentration increased as the moisture content decreased.

Badr (1980) reported that the salt concentration increased by decreasing moisture content. The control treatment (furrow irrigation) gave in general a low salt content with all over the soil layers at the different intervals of sampling. At the end of the experiment, the treatments of drip irrigation succeeded in leaching salt downwards till 30-35 cm, depth while accumulation of salts took place at the end of the season for drip treatment at 35-40 cm, depth.

### **2.4. Effect of irrigation water salinity, applied water volume and irrigation system on soil moisture content and its distribution:**

Bakr *et al.* (1979) found that soil moisture around the watermelon (*citrullus lanatus*) plant stems in the surface layer depth of 0-15 cm, after 24 h from irrigation was higher in the drip than that in both sprinkler and furrow irrigated plots.

El-Ebaby (1986) studied the soil moisture characteristic and distribution under drip irrigation condition. They found that moisture content generally decreased as soil depth increased and it was far from emitters. It reached its minimum value at mid-distance between emitters. After one day of irrigation, soil

retained water relatively equals to field capacity while after 2, 3 and 4 days a sharp decrease on moisture content was found. This maybe due to evaporation and plant consumption.

**Zartman and Gichuru (1984)** studied the effect of two irrigation water salinities having  $EC_{iw} = 12$  ds/m, SAR = 11 and  $EC_{w2} = 1.5$  ds /m, SAR = 4.5 on some chemical and physical properties of fine sandy loam soil in field plots for four years. They found that water retention and distribution were not significantly affected by irrigation water salinity.

**El-Kobia et al. (1986)** compared between furrow and drip irrigation systems and their effect on the soil moisture distribution in the root zone. Their results indicated that the highest mean value of soil moisture content was found directly under the emitters; however it decreased away from them. Under furrow system, there was a gradual decrease in soil moisture from bottom to top of line.

**El-Gindy (1988)** indicated that the soil moisture content differs through the soil profile layers due to the irrigation method. He added that the moisture content in the top layer profile of 0-20 cm of silt loam soil was higher in the drip irrigation fields than those of sprinkler and surface methods. Meanwhile, the lowest moisture content in the same layer was in the surface irrigated field.

**Abdel-Maksoud et al. (1992)** indicated that under drip system the moisture distribution in the soil increased through the surface layer of 0-30 cm compared with sprinkler. They stated that the moisture content decreased by decreasing of applied water.

**Abdel-Razek et al. (1992)** studied the effect of different irrigation system on soil moisture distribution in clay soil. They found that, less fluctuation in soil moisture content between furrows were obtained under furrow system, while drip

system resulted in nonuniformity distribution of soil moisture content between drip lines, but a better uniformity and a higher soil moisture content along the laterals were obtained under the 70 cm, between emitters treatment compared to the 100 cm, one. Soil moisture content before irrigation was higher for layer of 0-50 cm layer under drip irrigation system in comparison with sprinkler and furrow irrigation systems. After irrigation, the range of increasing rate in soil moisture content for layer of 0-50 cm were 79.65, 53.8 and 54, 15.7 % under furrow sprinkler and drip irrigation systems, respectively.

Mohamed (1995) stated that soil moisture content, decreased by increasing soil depth under both furrow and drip irrigation systems. Also, the soil moisture content, was higher under drip irrigation system than furrow one. This maybe due to the high efficiency of drip irrigation comparing to the furrow one.

## **2.5.Effect of irrigation water salinity and irrigation system on vegetative growth:**

### **2.5.1.Effect of irrigation water salinity on vegetative growth:**

Paliwal and Maliwal (1975) illustrated that cabbage growth decreased by increasing salinity in both sand culture and field experiments. The growth was highly reduced by a given salinity levels in sand culture than that in field experiments.

Moosa (1976) found that the growth of cotton plants decreased by increasing salinity levels of irrigation water.

El-Saidi *et al.* (1983) used a saline water which having electrical conductivity equal to 3000 ppm and fresh water as a control treatment to irrigation of cotton plants cultivar Giza 79 variety at early stage (beginning of budding till the appearance of 7<sup>th</sup> true leaf). They found that, the plant height and dry matter of

plant decreased by using the saline water comparison with that used fresh water in irrigation.

**Rathert (1983)** found that the dry matter of leaves and root and leaf : root ratio of two cotton varieties (Dandara and Giza 45) decreased by increasing salinity in irrigation water.

**Francois *et al.* (1984)** studied the effect of irrigation water salinity (1.5, 2.7, 5.0, 7.4, 9.8, and 12.1 ds/m) on plant growth with two varieties of sorghum (Double Tx and Nk 265) cultivated in clayey over calcareous soil. The results indicated that there was a reduction in plant height when the plants had approximately one month old. This was due to effect of salinity. The maximum plant height of both cultivars at maturity was significantly reduced by increasing salinity.

**Lotfy *et al.* (1987)** stated that increasing soil salinity levels intended to decreased height, dry mass of both shoots and roots as well as leaves number of cotton seedlings.

**Abdel-Al and Syiam (1990)** studied the effect of saline soils and irrigation water on cotton growth, yield and yield components. They used two types of saline water the first one having electrical conductivity equal to 11.99 mmhos/cm and the other having 0.54 mmhos/cm and electrical conductivity of irrigation water 6.37 mmhos/cm. The results indicated that in both clay soil types, irrigation period with saline water had a significant effect on dry mass, yield, yield components and the main fiber properties.

**Barakat (1996)** studied the effect of irrigation with saline water on growth and yield of potato. He found that the plant height, fresh and dry mass of the root were significantly reduced when soil salinity  $EC_e$  exceeded 7.1 ds/m. Also, the

fresh and dry mass of shoot were significantly, reduced when soil salinity  $EC_e$  was more than 3.82 and 3.6 ds/m in 1994 and 1995, respectively.

### **2.5.2. Effect of irrigation system on vegetative growth:**

**Bakr and Shakshook (1977)** found that the drip irrigation had better vegetative growth of cucumber and tomato plants and less water consumptive use comparing with both sprinkler and furrow irrigation. Drip irrigation gave the highest values of cucumber and tomato yield.

**Bakr et al. (1979)** stated that drip irrigation caused earlier flowering and better higher rates of watermelon vegetative growth and yield than sprinkler and furrow irrigation under the conditions of sandy loam-soil.

## **2.6. Effect of irrigation water salinity and irrigation system on crop yield:**

### **2.6.1. Effect of irrigation water salinity on yield:**

**Mass and Hoffman (1976)** stated that both two levels of salinity 1200 and 900 ppm ( $EC$  ranged from 2 to 1.5 ds/m) allow production of almost full yield of the sensitive crops, They also had tabulated a number of economic crops according to their tolerance to salt concentration and their expected yield percentage when specified leaching requirement is applied.

**Dutt et al. (1984)** noticed that irrigation water salinity ( $EC_{iw}$  of 6.2 ds/m) should be capable of producing a better than 90% yield and the water of  $EC_{iw}$  equal to 11 ds/m should be capable for giving at least 50% yield. They also found that lint cotton yields increased from 0.834 to 1.076 Mg /ha by increasing the salinity of irrigation water from 4 to 11.1 ds/m.

**El-Shakweer et al. (1984)** studied the effect of salinity and sodium adsorption ratio (SAR) of irrigation water on different varieties of Egyptian

cotton. They found that seed cotton yield was reduced to 60 % by raising the salinity of irrigation water from 2000 to 8000 ppm and to 80 % by raising adjusted SAR from 10 to 30. Reduction due to salinity was increased as adjusted SAR increased. Most varieties, especially Giza 80, were not negatively affected by salinity up to 4000 ppm.

**Van Hoorn (1984)** reported that water quality problem can occur in four general categories: salinity, permeability, toxicity and miscellaneous. Each of them may affect the crop singly or in a combination of two or more. A combination of problems may be more difficult to solve and may affect the crop production more severely than a single problem. He also found that the effect of salinity on crop growth is mainly ascribed to reduce water uptake by the crop. As the salinity of a solution increases, its osmotic potential increases too and reduces the availability of water for the crop. This osmotic effect may explain why vegetable crops which are known to prefer readily available soil water not exceeding a potential of 1 bar. They are so sensitive to salinity. He also found that the water quality test, certain crops especially vegetables already show severe reduction in yield between  $EC_e$  values of 2 and 4 ds/m. On the other hand, wheat, barley, sugar beet, cotton alfalfa and ray grass can tolerate much higher salinity levels.

**Francois *et al.* (1986)** studied the effect of salinity on germination and grain yield for wheat crop. They showed that no significant reduction of wheat crop with soil salinity up to 10.8 ds/m. However, with higher soil salinity, grain yield was significantly reduced. The decreased yield was the result of decreased seed mass per spike and individual seed mass.

**Rains *et al.* (1987)** stated that use of drainage water for irrigated cotton and sunflower with different water salinities (1500, 3000, 4500, 6000, and 9000 mg/l total dissolved solids (TDS)), water was used after the preplanting irrigation. The

saline treatments did not significantly reduce cotton yields. However, the yield of the sunflower was reduced by almost 40% at the highest salinity level of 9000 mg /l TDS. The sunflower crop was more sensitive to salinity than cotton.

**Al-Najium and Neimmah (1989)** reported that increasing water salinity up to 6 mmhos/cm significantly decreased growth and caused 50% reduction in the yield of cultivated tomato in sandy and sandy-loam soils.

**Abou-Hadid et al. (1988)** studied the effect of saline irrigation water  $EC_{iw}$  equal to 1.5 mmhos/cm, for tomato grown in sandy soil. Their results indicated that, irrigation tomato plants with saline water reduced both the rate of transpiration and the difference between air and leaf temperature. Moreover, the reduction in transpiration rate was coupled with reduction in plant growth and final yield.

**Ayars et al. (1988)** studied the managing saline irrigation water in arid areas with shallow ground water. They found that it is possible to use saline water having EC equal to 8 ds/m in conjunction with non saline water to grow salt tolerant crops. Nearly 70% of the irrigation water required for growing sugar beet and cotton was saline water drainage. He also reported that yield comparisons between saline irrigated and non-saline irrigated areas for the cotton and sugar beets showed that neither of these crops were suffered yield reductions due to the use of saline water for irrigation.

**Rhoades et al. (1988)** determined crop yields and changes in soil salinity when representative Imperial Valley drainage water was substituted for some of the Colorado River water, which conventionally was used for irrigation in the Valley. They found that, there was no significant differences in wheat and sugar beet yields occurred in cycle of the successive-crop rotation as a result of

substituting drainage water (even in the greater amount 65 to 75 percent) for colorado river water to irrigate these crops after seedling establishment.

**Selem *et al.* (1989)** pointed out that irrigation of cotton with drainage water reduced fresh and dry substance mass, number of leaves and bolls per plant, and mass of seed, lint and blossoms than treatment irrigated with fresh water.

**Abdel-Al and Syiam (1990)** stated that all yield components (number of bolls, boll weight, lint % and seed index) were significantly affected by type of soil and irrigation period with saline water, all these components were reflected to the yield of seed cotton/plant especially for irrigation at seedling stage, which gave the lowest value and flowering stage. The reduction in the yield was about 52.2 % for the seedling stage which could be considered the most critical period for salinity in the ontogenesis of cotton plant.

**Alam and Ali (1990)** found that the height, dry matter and yield of bajra plant grown on desert sand and graded soil were significantly decreased by increasing the salinity level of irrigation water up to 14.06 ds/m.

**Aly (1990)** studied the effect of irrigation with saline water on yield of berseem, wheat, rice and maize at Elhamol, Edko and Wadi areas. The results indicated that grain and straw yields of wheat decrease by increasing electrical conductivity values for both irrigation water and soil extract. The decrease in wheat grain yield due to the use of mixed water were 22.7, 23.6, and 26.4 % comparing to conventional irrigation water in El-hamoul, Edko and Wadi areas, respectively. While the use of drainage water caused a pronounced decrease of wheat grain yield, which reached 41.7, 59 and 55.3 % in the same areas, respectively. Results also showed that the reduction in maize grain yield due to the use of mixed water were 22.5, 34.3 and 32.3 % comparing to conventional water in Elhamol, Edko and Wadi areas, respectively. While the use of drainage



water caused a pronounced decrease of maize grain yield, which reached 56.2 , 69.6 and 67.2 % at same areas, respectively.

**El-Leithi *et al.* (1990)** studied the effect of water salinity on wheat yield in two seasons. They concluded that the grain yield was significantly decreased in second season by total substitution of Nile water with drainage water. While, no significant differences were found among the Nile water and mixed water treatments in the two seasons.

**El-Shewikh (1996)** reported that irrigation with low water quality had a significant effect of decreasing height barley plant. The treatments that irrigated by low quality of irrigation water were significant effect on grain, straw and total yield. The irrigation treatment of alternatively once of canal water followed with twice drainage water significant response to barley yield comparing to other treatments. The treatments of drainage water had a highly effect on decreasing grain yield of barley and straw yield. The results also indicated there was a highly significant decrease in fresh mass, and sorghum grain yield with irrigation water quality treatments.

**Abo-soliman *et al.* (1992)** studied the effect of irrigation with saline water on soil salinity and wheat yield which cultivated in silt clay soil. The results showed that the reduction percentages of grain yield were found to be 38.9, 43.72, 47, 48.1 and 57.92 % when drainage water having electrical conductivity equal to 1.6 mmhos/cm applied were two, four irrigations (at the end of the growing season), two, four and six irrigations (from the beginning of the growing season), respectively, comparing to the fresh water which having electrical conductivity equal 0.47 mmhos/cm.

**Abdel-Sayed *et al.* (1993)** stated that there was no significant differences in sugar beet yield when irrigation water with salinity levels of 1000,2000 and 3000

ppm were used for 4, 5 and 6 months in clay loam soil. This means that saline water with salinities up to 3000 ppm can be safely used to irrigate sugar beet crop.

**Sharma *et al.* (1994)** used a highly saline drainage water which having electrical conductivity equal to 10.5 to 15 ds/m to irrigate winter wheat on a sandy-loam soil. The results indicated that wheat yield obtained with fresh canal water as the potential value (100%) the mean relative yield of wheat irrigated with only saline drainage water was 74 % substitution of canal water at first post plant irrigation and applying, therefore, only saline drainage water, increased the yield to 84 % cyclic irrigations with canal and drainage water in different treatments resulted in yields of 88 % to 94 % of the potential yield.

**Aly *et al.* (1995)** studied the effect of drainage water that used to irrigate two cotton cultivars (Giza-45 and Mc Nair-220) on clay soil. They found that the total yield of cotton decreased with decreasing water quality of irrigation water for both cotton cultivars but the differences for Giza 45 were not significant. The Mc Nair-220 variety was more sensitive to water quality effects. The yield with drainage water was 62.8 % comparing to tap water.

**Mohamed (1995)** studied the effect of soil conditioning, irrigation systems, saline irrigation water and irrigation interval on cucumber yield cultivated on clay soil. His results indicated that the maximum yield of cucumber is obtained from the treatment of low irrigation water salinity (tap water which having electrical conductivity equal to 350 ppm) under the two irrigation systems at both 1991 and 1992 seasons.

**Amer *et al.* (1997)** studied the effect of water quality on some crops (cotton, rice and maize) production for five years (from 1991 to 1996). They reported that the continuous use of drainage water for five years in irrigation adversely affected

the crop yield. The reduction in yield of cotton, rice and maize in the first season were 7, 7 and 24.5%, respectively. But the reductions in the last season (5<sup>th</sup> year) were amounted to be 16.7, 8.0, and 31.0 %, respectively, comparing to the yield of these crops irrigated with fresh water.

#### **2.6.2. Effect of irrigation system on yield:**

**El-Ebaby (1986)** reported that the used drip irrigation system to irrigate cucumber crop in sandy soil. His results showed that the cucumber yield increased by about 3 times more than that obtained when furrow irrigation was used

**Younis (1986)** stated that the least amount of water required with higher yield to produce tomato in new lands was obtained under the trickle irrigation. The percentage increase in the net profit under this system were 11 and 14.8 % compared to furrow and sprinkler systems, respectively.

**El-Gindy (1988)** used three of different irrigation systems (drip, sprinkler and furrow) to irrigate tomato and cucumber crops in silt loam soil. He found that the yield of tomato increased under drip irrigation system by 33 and 53.6% over the furrow and sprinkler irrigation system, respectively. He also found that the cucumber yield increased by 54.5 and 154.9% under drip irrigation system comparing to furrow and sprinkler irrigation systems, respectively.

**Abdel-Maksoud *et al.* (1992)** studied the effect of three different irrigation systems (drip, sprinkler and furrow) to select the proper system of tomato irrigation in new land. The results indicated that the yield of tomato obtained under drip irrigation increased by 19.36 and 14.15 % comparing to the sprinkler and furrow systems, respectively.

● **Badr (1993)** determined the production of tomato, cucumber and muskmelon grown on sandy loam soil under drip and sprinkler irrigation system by using two qualities of irrigation water (high quality water of 0.6 mmhos/cm and saline water of 4.5 mmhos/cm). The obtained results showed that the highest yield of these vegetable crops were obtained under the conditions of drip irrigation and high quality of irrigation water.

**Mohamed (1995)** studied the effect of soil conditioning, irrigation water salinity, irrigation interval and irrigation system on cucumber crop cultivated in clay soil. His results indicated that the yield of cucumber under drip irrigation system is more higher than the obtained yield under furrow one in the treatments of saline irrigation water 2000 and 4000 ppm.

## **2.7.Effect of irrigation water salinity, applied water volume and irrigation system on (WUE):**

### **2.7.1.Effect of irrigation water salinity on water use efficiency (WUE):**

● **Boland et al. (1993)** mentioned that water use efficiency of wheat and peach were reduced when saline water was used for irrigation.

**Mohamed (1995)** studied the effect of irrigation water salinity on water use efficiency of cucumber decreased as a result of increasing the salinity of irrigation water up to 4000 ppm under both furrow and drip irrigation systems, regardless the other factors.

### **2.7.2.Effect of applied water volume on water use efficiency (WUE):**

● **Lin et al. (1983)** they reported that the values of water use efficiency (WUE) for tomato plant under drip irrigation system were increased by decreasing the amounts of irrigation water added.

**Ghazy *et al.* (1987)** studied the effect of soil moisture strength on water use efficiency (WUE) in clay soil. The result showed that where soil moisture fluctuated between a minimum value of 26% and a maximum value of 43% (depletion of 70% of the available water) gave the best WUE compared to the other treatments, while the moisture content of the soil did not go below a minimum of 31 and 37% (depletion of 50% of available water and depletion of 30% of available water), respectively.

**El-Nagar (1997)** stated that, water use efficiency was affected by varying amounts of irrigation water. He found that the water use efficiency were decreased by decreasing amounts of irrigation water, for fresh and dry yield of potato tuber production. The values of water use efficiency calculated by using actual seasonal evapotranspiration values that measured by gravimetric method were 9.32, 6.27 and 5.94 gm/l for the fresh yield, while these values were 2.51, 1.73, and 1.67 gm/l for the dry yield, under the application of 400, 300 and 200 mm/season, respectively.

### **2.7.3. Effect of irrigation system on water use efficiency (WUE):**

**El-Gindy (1984)** elucidate the effect of quantity and frequency of water application on pepper production using different irrigation techniques. He found that the sprinkler method produce the lowest yield and had also the lowest water use efficiency due to a low water application efficiency and high water losses by evaporation.

**El-Ebaby (1986)** reported that the WUE of cucumber plant under drip utilization irrigation was high and reached 14.5 kg/m<sup>3</sup> as compared to center pivot, sprinkler and furrow methods.

**Younis (1986)** studied different irrigation methods in Western Nobarria to produce tomato crop. He found that water requirements to produce one kg of

tomato were 0.63 0.173 and 0.067 m<sup>3</sup> under furrow, sprinkler and drip irrigation systems, respectively.

**El-Gindy (1988)** used three different irrigation systems (drip, sprinkler and furrow) to irrigate tomato and cucumber crops in silt loam soil. He found that the water use efficiency (WUE) were 16.47, 5.23 and 6.11 kg/m<sup>3</sup> for tomato and 7.47, 5.23 and 2.38 kg/m<sup>3</sup>, for cucumber under drip, sprinkler and furrow irrigation systems, respectively.

**Abdel-Maksoud *et al.* (1992)** irrigated the tomato crop in new lands by using three different of irrigation systems (drip, sprinkler and furrow). Their results indicated that the values of water use efficiency (WUE) under drip irrigation was of 10.96 kg/m<sup>3</sup> increasing by 19.34 % and 14.4% than the sprinkler and furrow systems.

**Mohamed (1995)** noticed that the use of drip irrigation for cucumber plant highly increased WUE, as compared to furrow system, in all cases. Therefore, it can be concluded that drip irrigation is considered as the very suitable method for water management to obtain the highest yield and save more water.

## **3. MATERIALS AND METHODS**

The field experiment was carried out in the North of El-Tahrir District, El-Behaira Governorate, Egypt. This area is located at about 5 km from the desert road (Ciro-Alexandria).

The aim of the present work was to study the possibility of use of drainage water to irrigate corn and sunflower crops by using drip and surface irrigation systems.

### **3.1. Variables:**

#### **3.1.1. Irrigation systems:**

Two of irrigation methods were used in the present study as follows:

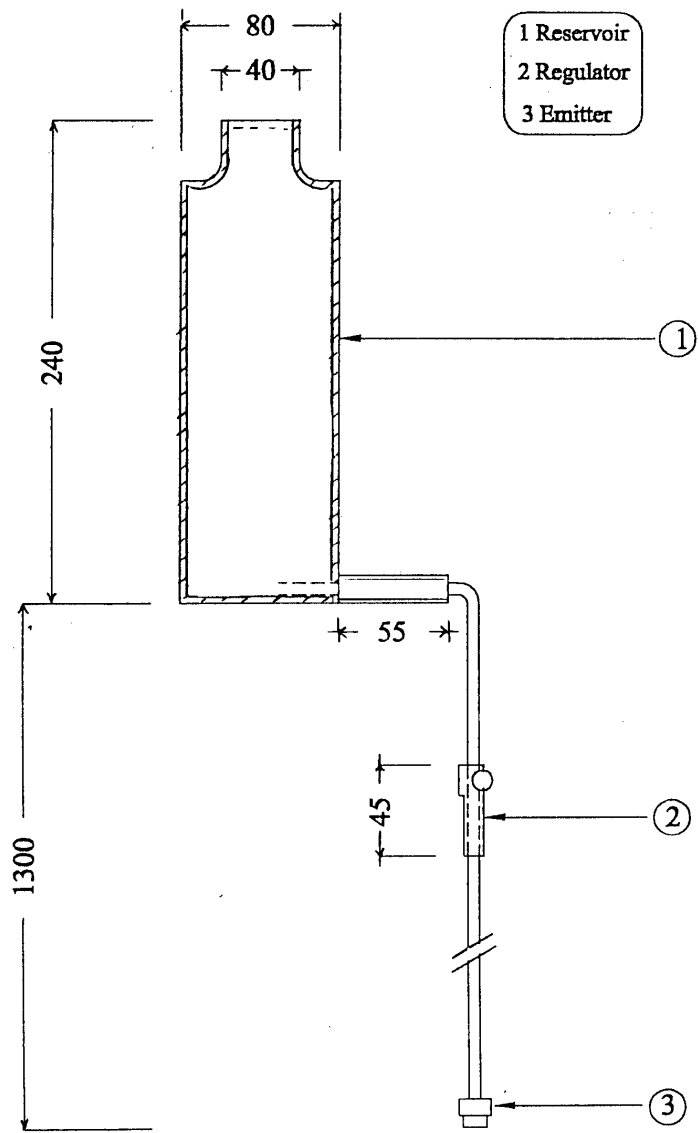
- a) Flood irrigation system.
- b) Drip irrigation system

A model of drip irrigation system, used in this study consists of reservoir, regulator and emitter. Operating pressure head was constant during experiment by fixing the reservoir at 1.54 m from the emitter as shown in Fig.1. The lateral spacing was 80 cm and the distance between emitters was 60 cm. Under flood irrigation, the distance between furrows was 70 cm and the distance between plants was 60 cm.

#### **3.1.2. Applied water volume:**

The present study included three different amounts of applied water volume per season per feddan for corn and sunflower as shown in Table 1

The water consumption for corn and sunflower were calculated by Attia et al. 1994<sub>a</sub> and Attia et al. 1994<sub>b</sub> methods, respectively.



Dimension in mm

Fig.1 :Model of drip irrigation which used in the experiment.



### **3.1.3. Water quality treatments:**

Four water qualities were used in the present study and it is obtained by mixing fresh water with drainage water as follows:

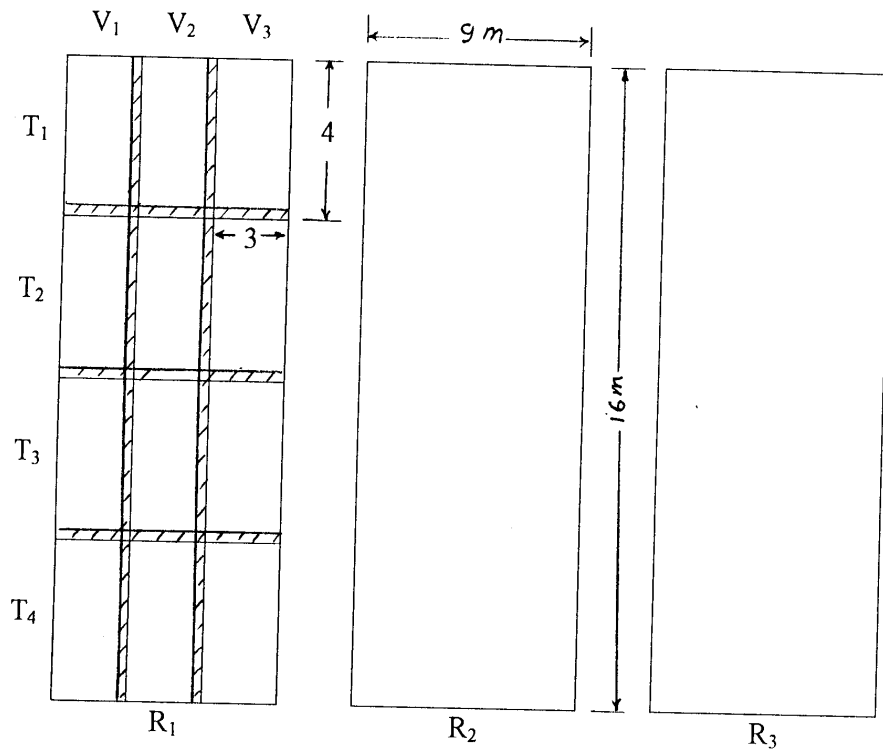
- a) Fresh water having an average electrical conductivity along growing season, EC of 1.33 mmhos/cm.
- b) Mixed water (2fresh water:1drainage water) by volume which having an average electrical conductivity along growing season EC of 2.087 mmhos/cm.
- c) Mixed water (2drainage water:1fresh water) by volume which having an average electrical conductivity along growing season EC of 2.85 mmhos/cm.
- d) Drainage water which having an average electrical conductivity along growing season EC of 3.61 mmhos/cm.

Table 1: The amount of applied water volumes for corn and sunflower

Applied water volume m <sup>3</sup> /fed/season	Crop type			
	Corn		Sunflower	
	Irrigation system		Irrigation system	
	Flood	Drip	Flood	Drip
V1	2066.4	1215.48	2314.2	1360.8
V2	2755.2	1621.20	3087.0	1814.8
V3	3444	2029.44	3855.6	2268.0

### **3.2. Experimental design**

In the present study, thirty six equal plots each 12 m<sup>2</sup> were designed as split plot with completely randomized blocks of three replications as shown in Fig.2. The main plots were the amount of applied water volume and sub-plots were different water salinity.



T- Type of water (four types).

V- Volumes of applied water (3 volumes).

R- Replicates (3 replicates).

Fig.2: Split plot design for both drip and flood irrigation experiment.

### **3.3.cultivated crops**

Corn (Single cross-10) and sunflower were planted during the summer season of 1997. Seeds were sown in 25 May, three seeds were sown in each hill, after twenty-one days the seedling were thinned to one plant per hill. Corn and sunflower were irrigated each 13-day under flood irrigation and each two days under drip irrigation system.

### **3.4.Methods of analysis:**

#### **3.4.1.Soil analysis.**

Soil chemical and mechanical analysis were carried out at Nobaria agricultural research center, soils department.

#### **3.4.1.1.Soil physical analysis.**

- 1) Particle size distribution, was carried out by using the international pipette method according to Richards (1954)
- 2) Calcium carbonate, was determined volumetrically by using the collin's calcimeter , Richards (1954)
- 3) Soil bulk density was determined according to Black (1965).

#### **3.4.1.2. Soil chemical analysis:**

Chemical analysis were carried out according to Jackson (1967) and included:

- 1-Electrical conductivity (EC) mmhos/cm determined in soil paste extract by using electrical conductivity meter.
- 2-Soil reaction (pH) was determined in 1 soil : 2.5 water by using Beckman pH meter.
- 3- Calcium and Magnesium: were determined by using versinate method. Eriochrom black T was used as an indicator for determining calcium plus magnesium and ammonium purporate was used as an indicator for determining calcium. Magnesium was calculated by difference.

- 4- Sodium and potassium: were determined photometrically by using Beckman flame photometer.
- 5- Carbonates and Bicarbonates: were determined by titration against 0.025 N Sulphuric acid using phenolphthalein and methyl orange as indicators.
- 6- Chloride was determined by titration with 0.02 silver nitrate solution and potassium chromate as indicator.
- 7- Sulphate was calculated by the difference between total cations and total anions.

### 3.4.2. Water chemical analysis:

Chemical analysis of water was carried out according to Jackson (1967).

Water samples were collected periodically before every irrigation from irrigation canal and the nearest collector drain ditch. These samples were directly analyzed chemically.

Table 2: The Mechanical analysis of the soil used in experiment.

Sample depth, cm				Soil texture
	Sand, %	Silt, %	Clay, %	
0-30	82.5	5.00	12.5	Sandy loam
30-60	70.0	20.0	10.0	Loam

Table 3: The chemical analysis of the soil used in experiment.

Sample Depth, cm	PH	EC, mmho/cm	Cations, meq/l				Anions, meq/l			
			Ca	Mg	Na	K	CO <sub>3</sub>	HCO <sub>3</sub>	Cl	SO <sub>4</sub>
0-30	7.8	3.38	37.5	1.25	10.75	1.83	0.2	18.55	28.13	4.45
30-60	7.9	1.6	13.75	2.00	7.25	0.75	0.05	6.19	14.38	3.13

Table 4: Bulk density and soil moisture content of soil at different depths 0, 15, 30 and 45 cm before carrying out experiment

Depth, cm	$\rho_b$ , g/cm <sup>3</sup>	M.C, %
0	1.7	3.1
15	1.6	14.1
30	1.5	16.8
45	1.5	19.8

Table 5: The chemical analysis of fresh irrigation water samples

Irrig. No.	PH	EC, mmhos/cm	Cations, meq/l				Anions, meq/l			
			Na	Ca	K	Mg	CO <sub>3</sub>	HCO <sub>3</sub>	Cl	SO <sub>4</sub>
1	8.1	1.45	.0	10.0	0.	3.5	0.01	8.0	6.0	3.89
2	8.3	1.51	3.51	7.8	0.16	3.63	0.04	9.96	5.0	0.10
3	7.5	1.22	8.2	4.1	0.23	1.94	0.7	3.6	5.0	5.17
4	7.5	1.22	8.2	4.1	0.23	1.94	0.7	3.6	5.0	5.17
5	7.7	1.39	8.6	5.5	0.25	3.3	0.0	3.7	5.0	8.95
6	7.7	1.39	8.6	5.5	0.25	3.3	0.0	3.7	5.0	8.95
7	7.6	0.99	5.4	5.0	0.2	2.0	0.0	3.2	3.2	6.2
8	7.2	1.45	7.1	9.0	0.25	3.5	0.01	4.5	6.5	8.84

Table 6: The chemical analysis of drainage water samples

Irrig. No.	PH	EC, mmhos/cm	Cations, meq/l				Anions, meq/l			
			Na	Ca	K	Mg	CO <sub>3</sub>	HCO <sub>3</sub>	Cl	SO <sub>4</sub>
1	8.0	4.1	11.0	20.0	0.5	10.0	0.0	9.0	30.0	2.50
2	8.1	3.9	10.7	23.8	0.44	9.75	0.02	9.98	28.0	6.69
3	7.0	3.1	20.0	7.4	0.37	5.4	0.3	3.4	16.4	13.07
4	7.0	3.1	20.0	7.4	0.37	5.4	0.3	3.4	16.4	13.07
5	8.0	3.68	24.6	13.0	0.43	4.1	0.04	3.9	19.0	19.19
6	8.0	3.68	24.6	13.0	0.43	4.1	0.04	3.9	19.0	19.19
7	6.8	2.24	12.6	10.7	0.3	3.1	0.0	3.5	9.0	14.2
8	7.3	5.1	12.7	22.5	1.3	13.0	0.05	5.45	40.0	4.0

### **3.5. Indices:**

#### **3.5.1. distribution of soil moisture and salt content.**

1- Soil salinity and moisture content.

To determine salinity and soil moisture content, soil samples were taken before and after two hours from irrigation in four different locations from emitters 0, 15, 30 and 45 cm at four different profile depths of 0, 15, 30 and 45 cm under drip irrigation. In the flood irrigation soil samples were taken at four different depths 0, 15, 30 and 45 cm.

The soil moisture content was determined by taking the soil samples and drying at 105 °C for 24 h, then the soil sample was weighed directly after drying, and wet samples also weighed. Therefore, the soil moisture content was calculated according to the following equation:

$$\% \text{ M.C} = \frac{\emptyset_1 - \emptyset_2}{\emptyset_2}$$

Where:

$\emptyset_1$  = weight of soil sample before drying

$\emptyset_2$  = weight of soil sample after drying.

To determine soil salinity, a soil water extract was prepared by adding 5g soil to 25 ml water as a ratio of (1:5 by weight). The electrical conductivity meter was used to measure soil salinity in mmhos/cm.

#### **3.5.2. Vegetative growth:**

The plant height, leaf area and stem diameter of corn and sunflower were recorded for each plot at different stages of growth (after 21 and 50 day from planting and at harvesting date).

The leaf area was measured by using planimeter, and plant height was measured by tape. The peripheral of stem was calculated as follows:

$$\text{Ph} = \frac{D}{2}$$

Where:

Ph is Peripheral of stem and D diameter of stem

Leaf area index was calculated by using the following equation.

$$\text{Leaf area index} = \frac{\text{L.A}}{\text{S.A}}$$

Where:

L.A leaf area per plant (by taken leaf area of all leaves of plant)  
and S.A spacing area per plant

### **3.5.2.Crop yield:**

The plots were harvested at maturity of crop. Corn was harvested on 15<sup>th</sup> of September, 1997 and sunflower was harvested on 5<sup>th</sup> of September, 1997. Grain yield of each plot (1m x 1m) of corn and sunflower was obtained and separately weighed, and values were multiplied by 4200 to get on yield per feddan.

### **6.3.Water use efficiency:**

Water use efficiency is the ratio between crop yield and total amount of used irrigation water and expressed by kg of yield per m<sup>3</sup> of used irrigation water, and it is calculated by using the following equation:

$$\text{WUE} = \text{Y} / \text{A.I.W.}$$

Where:

Y grain yield in kg/fed

A.I.W. applied irrigation water in m<sup>3</sup>/fed.



## 4. RESULTS AND DISCUSSION

the present work was to study the effect of irrigation water salinity, applied water volume and irrigation systems on the following:

### 4.1. Distribution of salt in the soil profile

Salinity control is one of the major objectives of irrigation management because it effects on crop yield. The key to salinity control is deep percolation of soil water through the root zone. The appropriate irrigation method is that which removes the salts from soil, or at least reduces the concentration of salts in soil solution to a suitable level for grown plants, or at least gives a proper and adequate salt balance in favour of plant growth.

Under flood irrigation system the soil salinity increased with soil depth after irrigation. But before the next irrigation soil salinity decreases with depth due to movement of salts from subsurface layers to surface layer by capillary force.

Figures 3, 4 and from 5 to 10 in appendix indicate the effect of applied water volume and salinity of irrigation water on salt content and distribution in soil profile. The obtained data was agreed Mohamed (1995) and Omer and Aziz (1982), they found that the increasing in soil salinity ( $EC_e$ ) was significant and proportional to salt concentration in irrigation water.

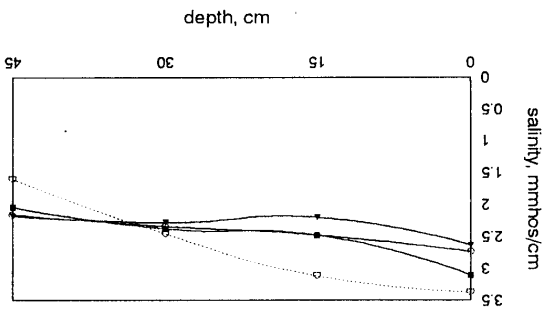
The applied water volume had a highly significant effect on salt content in soil profile. Increasing the amount of applied water volume tends to decrease the soil salinity because moisture content increased with increasing the amount of applied water and matric potential. Therefore, the capillarity action by which salts rise towards the upper soil layer will be depressed. Also, the amount of percolation water is increased and reduced the salt content in this soil layer (Kumar et al., 1985 and Abdel-Maksoud et al. 1993).

Under drip irrigation system, the soil salinity increased by increasing the distance from emitter in both directions (vertical and horizontal), as shown in Figs.11 and from 12 to 18 in appendix, Data indicated that far from emitters the soil profile has a high value of salt content ( $EC_e$ ) in surface layers compared to soil profile beside the emitters which has a lower values of salt content ( $EC_e$ ), these results maybe due to the fact that, soil mass beneath the emitters more saturated with water and matric potential reaches zero. Under these conditions, soil water potential will be function of gravitational potential and osmotic potential as additive values. But far from the emitters, the soil will be under more unsaturated conditions and contribution of osmotic potential will be much smaller than that of the matric potential to the values of soil water potential.

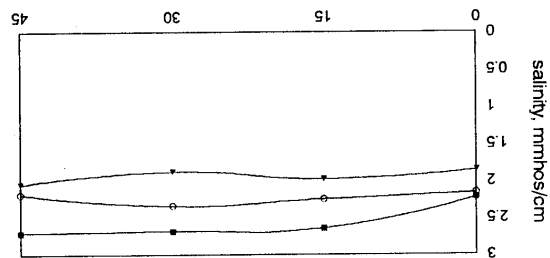
The values of salt content in the root zone under flood irrigation system were higher than the values under drip irrigation due to increase of irrigation frequencies in drip irrigation. Therefore, the lowest values of soil salt content ( $EC_e$ ) were obtained in the treatments irrigated by canal water (EC of 1.33 mmhos/cm), with high amount of applied water under drip irrigation system for corn and sunflower.

In general, increasing the salt content in irrigation water tends to increase the soil salt content.

Regression analysis was followed and the multi regression equations were developed to described the relationship between the salt content change (Y) as affected by applied water volume (v) and irrigation water salinity (t) as shown in Table 55. The statical analysis revealed that, there is a highly correlation between salt content change and both applied water volume and irrigation water salinity. The difference between predicted and measured values are low as shown in Table 56.



After irrigation  
 + 2066.4 m<sup>3</sup>/season + 2755.2 m<sup>3</sup>/season  
 + 3444 m<sup>3</sup>/season



After irrigation  
 + 2066.4 m<sup>3</sup>/season + 2755.2 m<sup>3</sup>/season  
 + 3444 m<sup>3</sup>/season

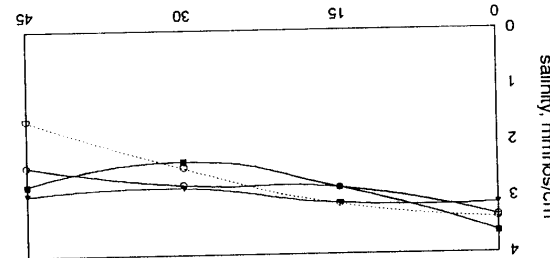


Fig. 3: Effect of applied water volume on salt content at 1.33 mmhos/cm, irrigation water salinity under flood irrigation for corn.

Fig. 4: Effect of applied water volume on salt content at 2.087 mmhos/cm, irrigation water salinity under flood irrigation for corn.

Across lateral

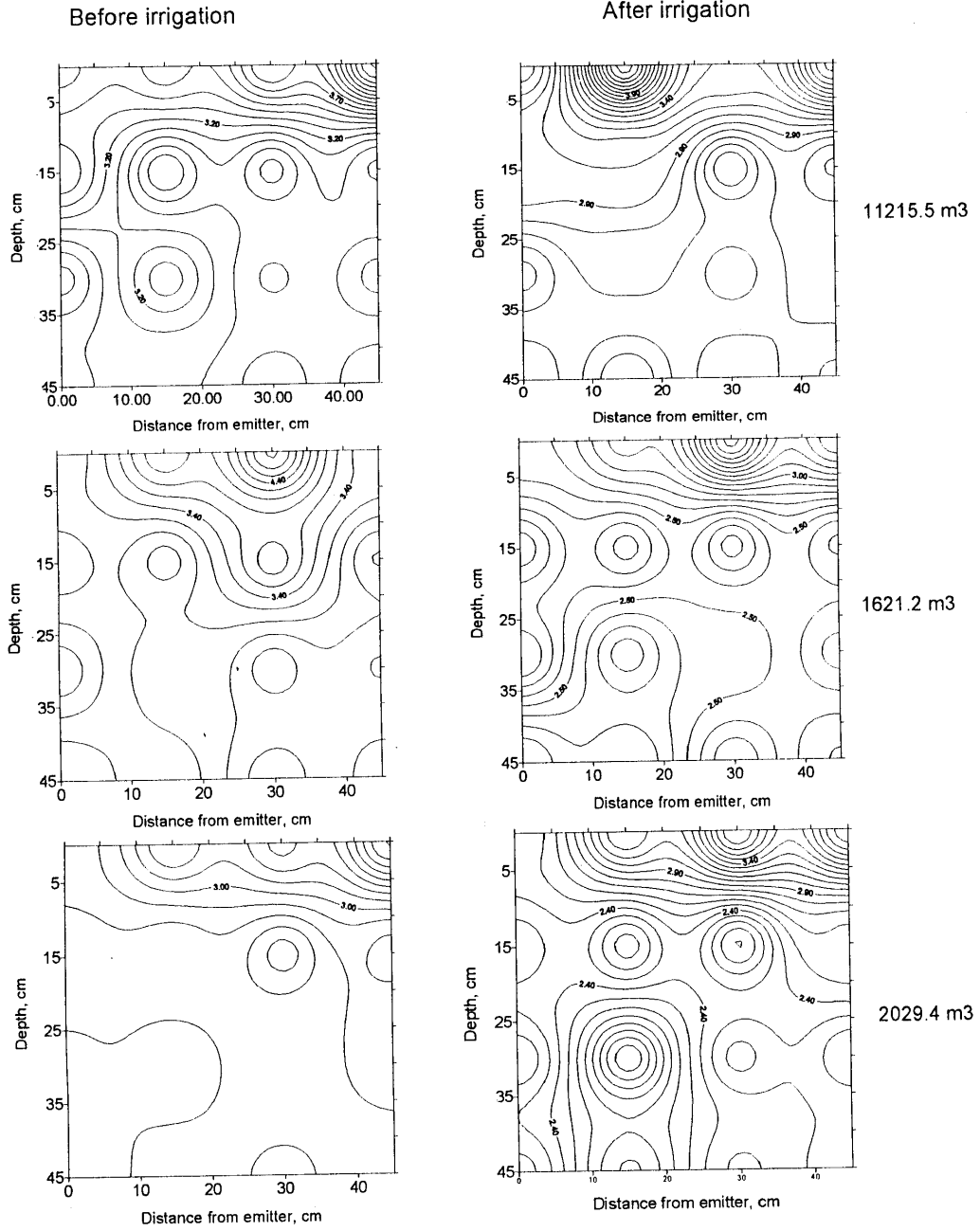


Fig.11-a: Salt content and distribution as affected by applied water volume under drip irrigation at 1.33 mmhos/cm irrigation water salinity for corn

## **2- Distribution of soil moisture content:**

The soil moisture content was affected by many factors such as soil properties (pore size distribution, porosity), soil and water management, water quality and irrigation systems. The soil moisture content was carried out at the end of both corn and sunflower growing season .

Figures 19, 20 and from 21 to 26 indicate that, the soil moisture content generally decreased with the depth of soil during irrigation period under flood irrigation system. flood irrigation system takes high amount of applied water that is able to infiltrate quickly downward through the soil profile.

The results revealed that increasing of applied water volume tends to increase wetted soil volume due to increasing movement of water in both direction (horizontal and vertical).

### **Soil moisture content under drip irrigation system.**

Figures from 27 and from 28 to 34 illustrate the effect of applied water volume and water quality on the soil moisture content and distribution in soil profile. The soil moisture content decreased by increasing the distance from emitters. The applied water volume had a highly significant effect on soil moisture content and its distribution.

Data also revealed that soil moisture content is more pronounced in the surface layer 0-15 and 15-30 cm comparing to the deeper layers especially in the treatments of drip irrigation system. This may be due to high efficiency of drip irrigation in controlling water in the root zone.

The results also revealed that the soil moisture content is not affected by irrigation water salinity levels. This may be due to that the range of water salinity is not high, but it can be stated that the available water may be decrease as a

result of increasing irrigation water salinity. This finding is in agreement with Zartman and Gichuru, 1984.

The soil moisture content increased in both directions (vertical and horizontal directions), by increasing the amount of applied water volume.

The soil moisture content and its distribution in the soil profile in the root zone was higher in drip irrigation system than the flood irrigation. This may be due to high efficiency of drip irrigation for water management comparing with the flood irrigation, and more frequency of wetting and drying process under drip irrigation which enhance the formation of more water stable aggregates having capacity for retained water. In addition, the roots distribution is more intensive under drip irrigation than flood irrigation, which also introduces more holding forces of soil towards its content of water.

Finally, it can be reported that the results of the study for soil moisture content and distribution can be summarized as follows:

1-Drip irrigation system provides the soil with the suitable conditions of moisture content and aeration in the root zone.

2-Drip irrigation provides plant by the suitable amount of water requirements to the growing crops (corn and sunflower) without any percolation losses.

3-Fertilizers can be easily added with irrigation water through this system of irrigation without any losses and with high economic efficiency to plants.

4-Drip irrigation saves more water an about (41%) from water requirements comparing with the flood irrigation.

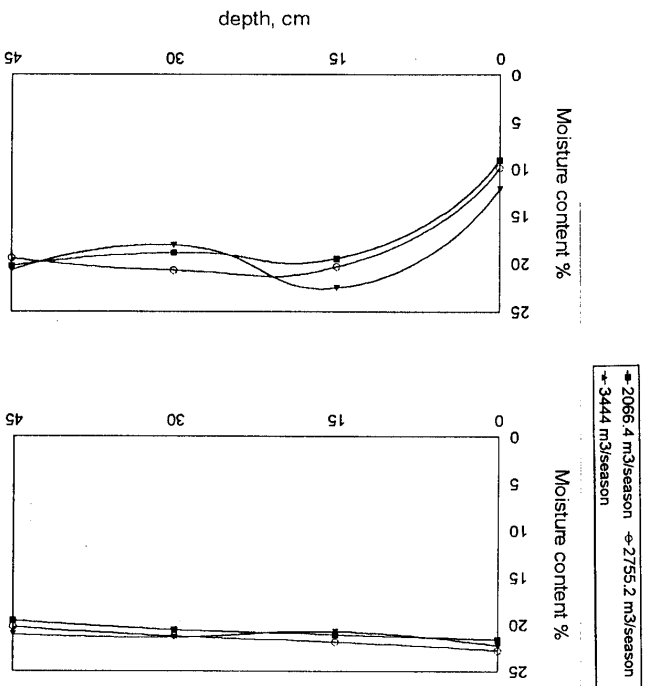


Fig.19: Effect of applied water volume on soil moisture content at 1.33 mmhos/cm, irrigation water salinity under flood irrigation for corn.

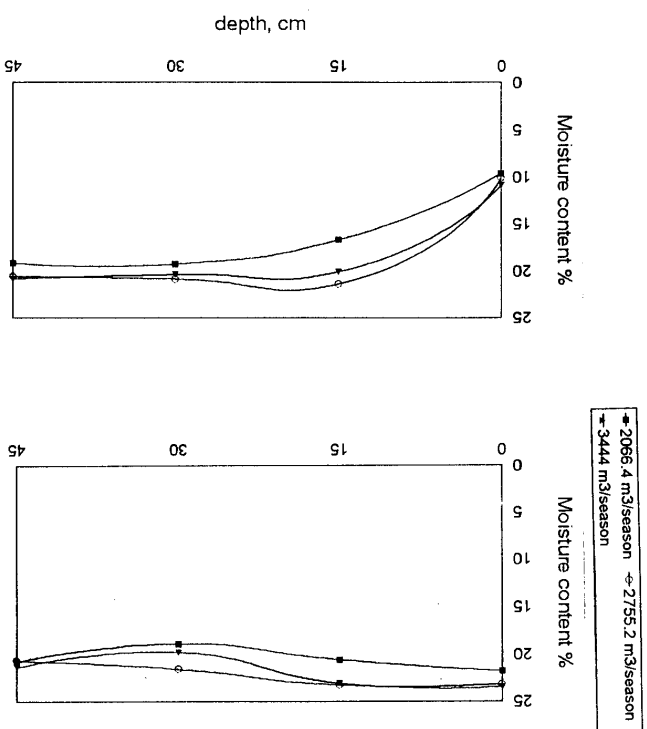


Fig.20: Effect of applied water volume on soil moisture content at 2.087 mmhos/cm, irrigation water salinity under flood irrigation for corn.

# Across lateral

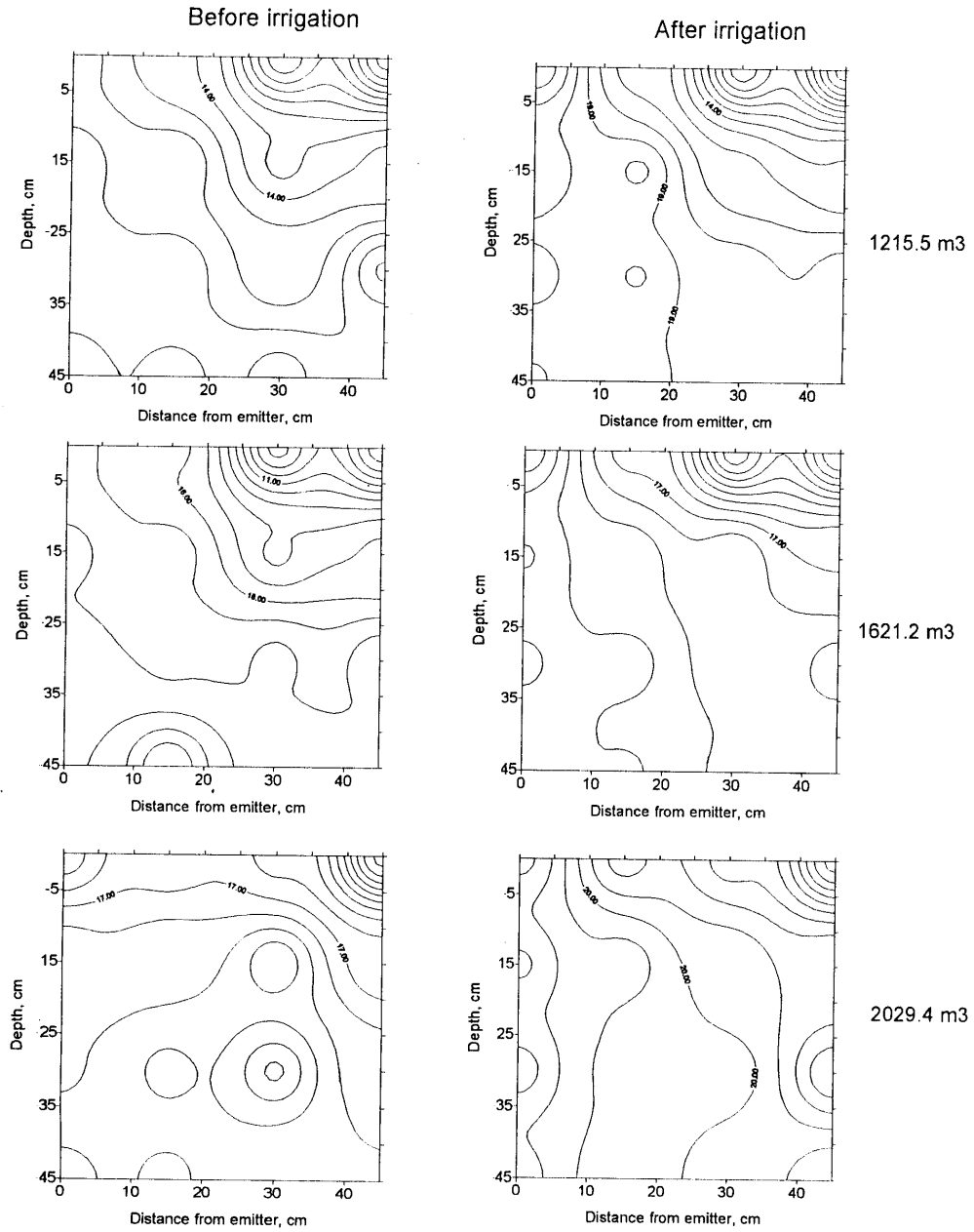


Fig.27-a: Soil moisture content and distribution as affected by applied water volume under drip irrigation at 1.33 mmhos/cm irrigation water salinity for corn



### **3. Vegetative growth of corn and sunflower:**

#### **3.1. corn plant:**

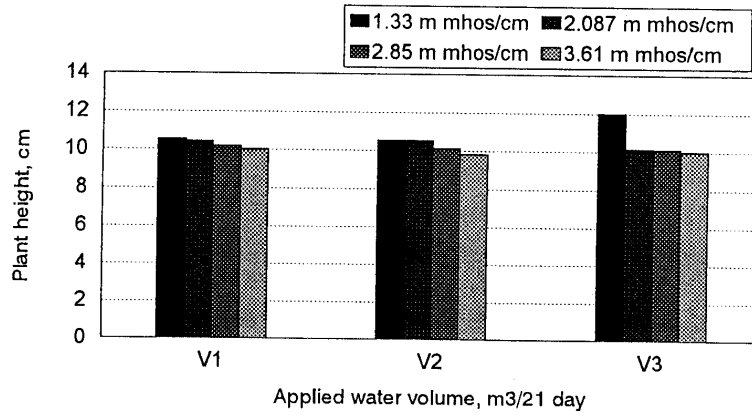
##### **3.1.1. Plant height**

Plant height of corn was affected by irrigation water salinity as shown in Figs. 35, 36 and Tables from 7 to 12, Figs. from 37 to 40 in appendix. The irrigation water salinity had a highly significant effect on plant height of corn under both irrigation systems (drip and flood) at all stages of growing season, especially in the first stage and at harvesting.

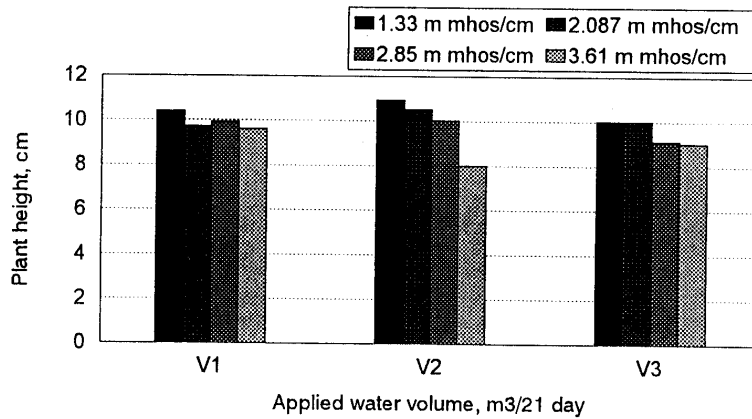
In general, it can be reported that irrigation with low water quality (drainage water EC of 3.61 mmhos/cm) has a great effect on decreasing the plant height. This may be due to the main function of good water quality (canal water EC of 1.33 mmhos/cm) in building new cells and their elongation.

Also results in the same tables and figures showed that in the first stage (after 21 day from sowing) plant height is not significantly affected by various amounts of applied water volume under both irrigation systems, but at the two other stages (after 50 day from sowing and at harvesting), applied water volume had a highly significant effect on corn plant height. This may be due to that the plant at starting of growing season has small roots, therefore, water demand is small. but at the end of growing season, the plants have a long roots and water demands are high.

The plant height under drip irrigation is taller than the plant height under flood irrigation at all stages of growing season, except the first stage. This may be due to high efficiency of drip irrigation in providing the suitable amount of water and fertilizer without any losses at all stages of growing season.



**Fig. 35: Effect of applied water volume and irrigation water salinity on corn plant height after 21 day from sowing under flood irrigation**



**Fig. 36: Effect of applied water volume and irrigation water salinity on corn plant height after 21 day from sowing under drip irrigation**

The maximum value of corn plant height of 196 cm was obtained from the treatments of received canal water (EC of 1.33 mmhos/cm), under drip irrigation system.

### **3.1.2. Stem diameter:**

Stem diameter of corn was affected by irrigation water salinity as shown in Tables from 13 to 18 and Figs from 41 to 46. The irrigation water salinity had a highly significant effect on stem diameter of corn under both irrigation systems (drip and surface), especially at the late stages (after 50 day from sowing and at harvesting)

In general, it can be reported that irrigation with low water quality (drainage water EC of 3.61 mmhos/cm) has a great effect on decreasing the stem diameter, this may be due to the main function of good water quality (canal water EC of 1.33 mmhos/cm) in building new cells.

Stem diameter of corn was affected by the amount of applied water volume as shown in the same Tables and Figures. The amount of applied water volume had a highly significant effect on stem diameter, especially in the first two stages (after 21 day from sowing and after 50 day from sowing) under both irrigation systems (drip and flood), but at harvesting stem diameter was not significantly affected by various amounts of applied water volume under surface irrigation system.

Data also showed that the stem diameter under drip irrigation system is larger than under to the flood irrigation at all stages of growing season. This may be due to high efficiency of drip irrigation system in water management and fertilizer supply.

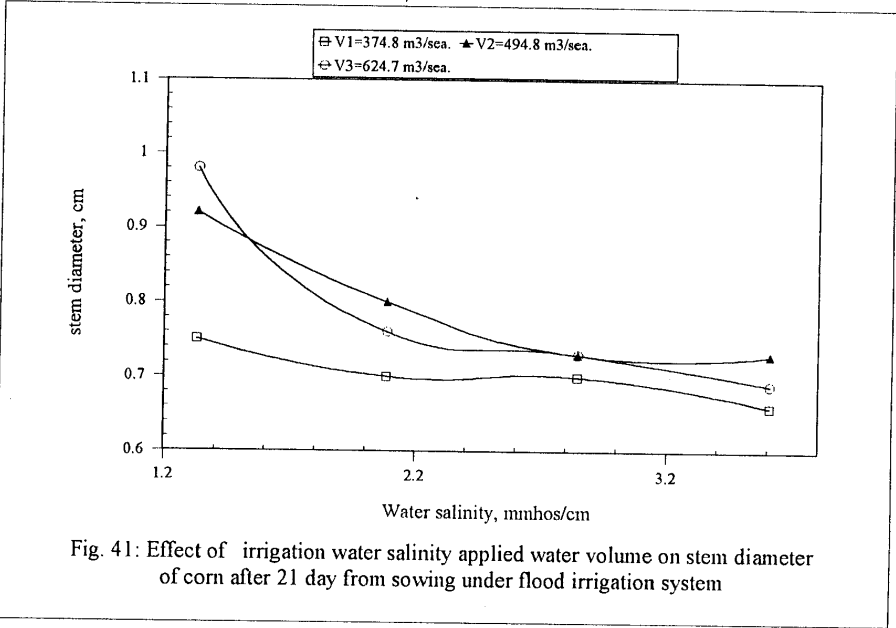


Fig. 41: Effect of irrigation water salinity applied water volume on stem diameter of corn after 21 day from sowing under flood irrigation system

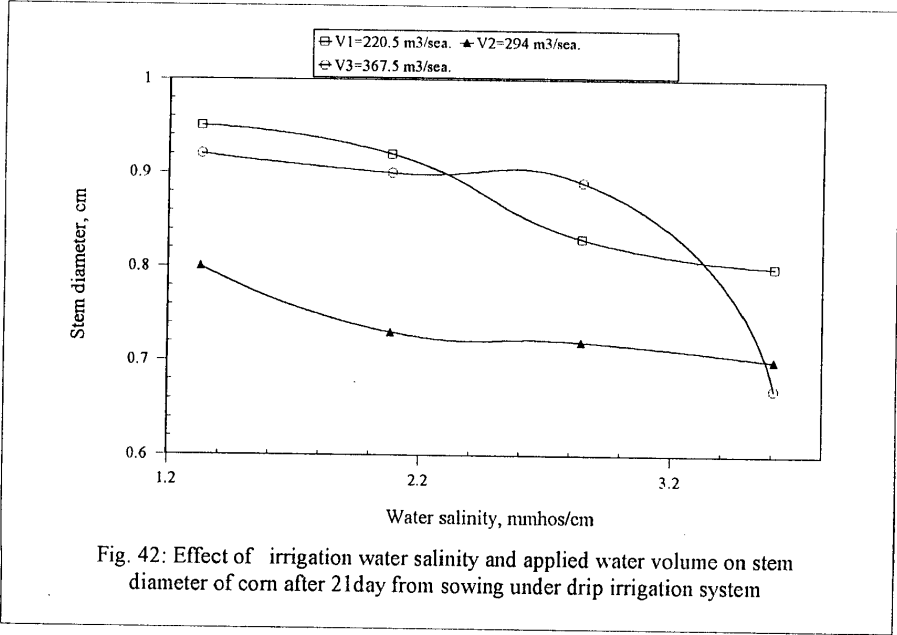


Fig. 42: Effect of irrigation water salinity and applied water volume on stem diameter of corn after 21 day from sowing under drip irrigation system

The maximum value of corn stem diameter of 2.75 cm, was obtained from the treatments that received canal water (EC of 1.33 mmhos/cm), and 3444 m<sup>3</sup>/season, of applied water under drip irrigation system at harvesting.

### **3.1.3. Leaf area index:**

Leaf area index of corn was affected by irrigation water salinity as shown in Tables from 19 to 22 in appendix and illustrated in Figs.47, 48 and from 47 to 50 in appendix which showed that water salinity had a highly significant effect on leaf area index of corn at all stages of growing season. The irrigation water salinity had a highly significant effect on leaf area index of corn, especially at harvesting, this maybe due to high osmotic pressure in the root zone, therefore, reducing leaf area per plant.

Data presented in the same tables and figures showed that the leaf area index is high significantly affected by various amounts of applied water volume, especially at the first stage and at harvesting under both irrigation systems (drip and flood irrigation systems).

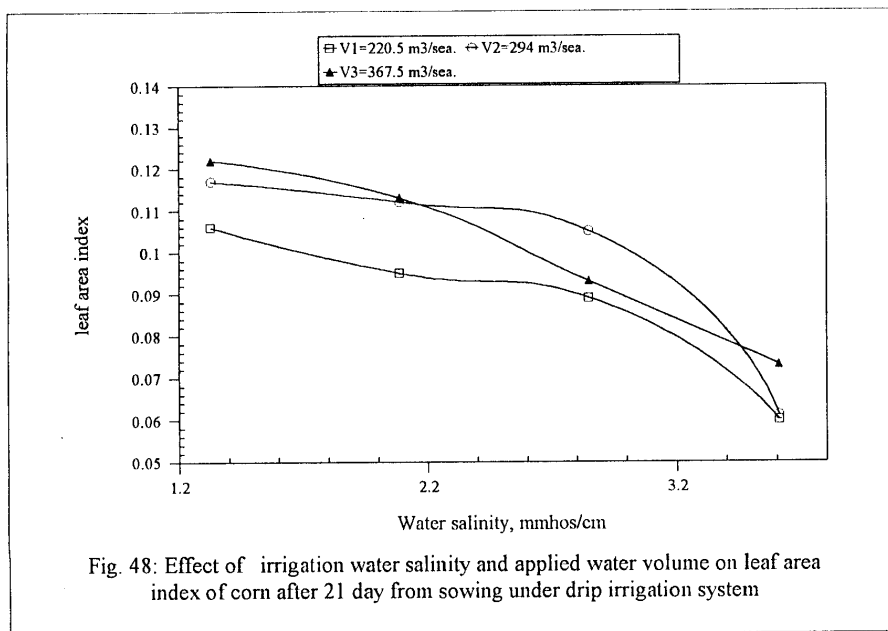
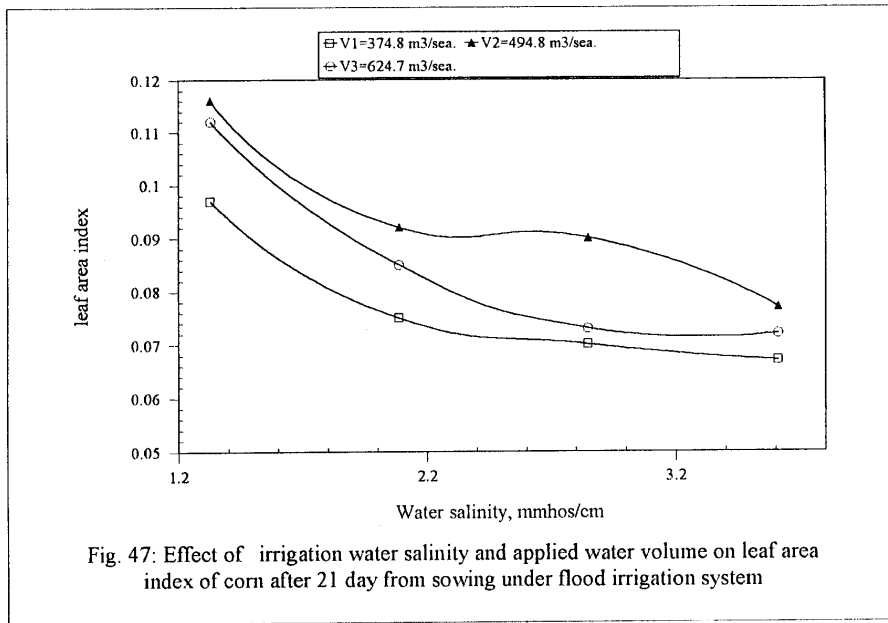
Data also showed that leaf area index under drip irrigation is higher compared to the flood irrigation at all stages of growing season. This may be due to that drip irrigation provides the plants by the suitable amount of water and fertilizers without any losses.

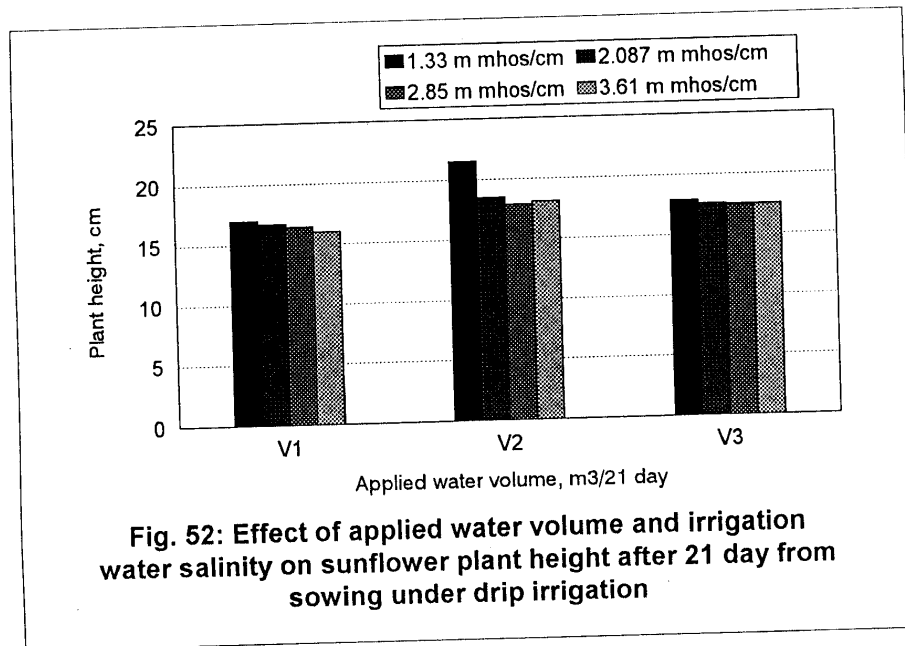
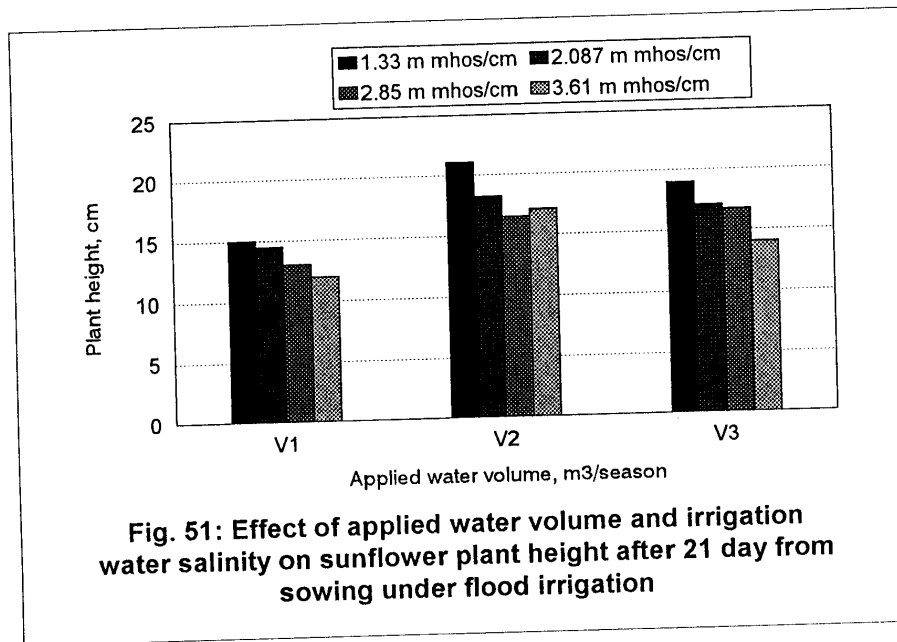
The maximum leaf area index of 2.01 at harvesting was obtained from the treatments that received canal water (EC of 1.33 mmhos/cm), and 2029.4 m<sup>3</sup>/season, of applied water under drip irrigation system with canal water.

## **3.2.Sunflower plant:**

### **3.2.1.Plant height.**

Plant height of sunflower was affected by irrigation water salinity as shown in Tables from 23 to 28 in appendix and illustrated in Figs 51, 52 and from 53 to





56 in appendix. The irrigation water salinity had a highly significant effect on plant height of sunflower, especially at harvesting under drip irrigation, this may be due to sunflower unlikely water and it have along root, which far from the wetted zone.

It can be reported that irrigation with low water quality (drainage water EC of 3.61 mmhos/cm) decreases plant height of sunflower. This may be due to the function of good water quality in building new cells and their elongation.

Data presented in the same tables and figures showed that the plant height is high significantly affected by various amounts of applied water volume at all stages of growing season under both irrigation systems (drip and flood), except at harvesting under surface irrigation system. Treatments at this period do not show any significant effect on plant height.

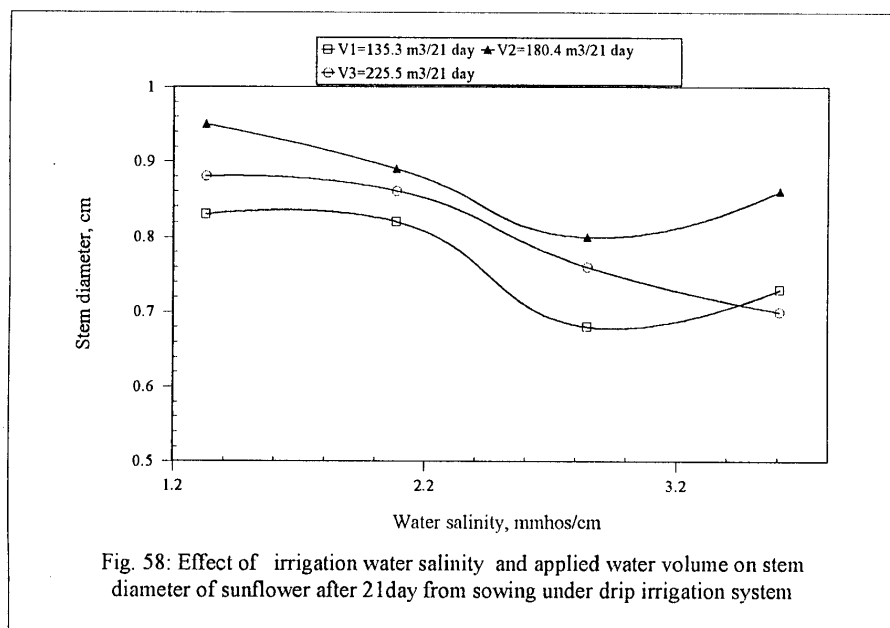
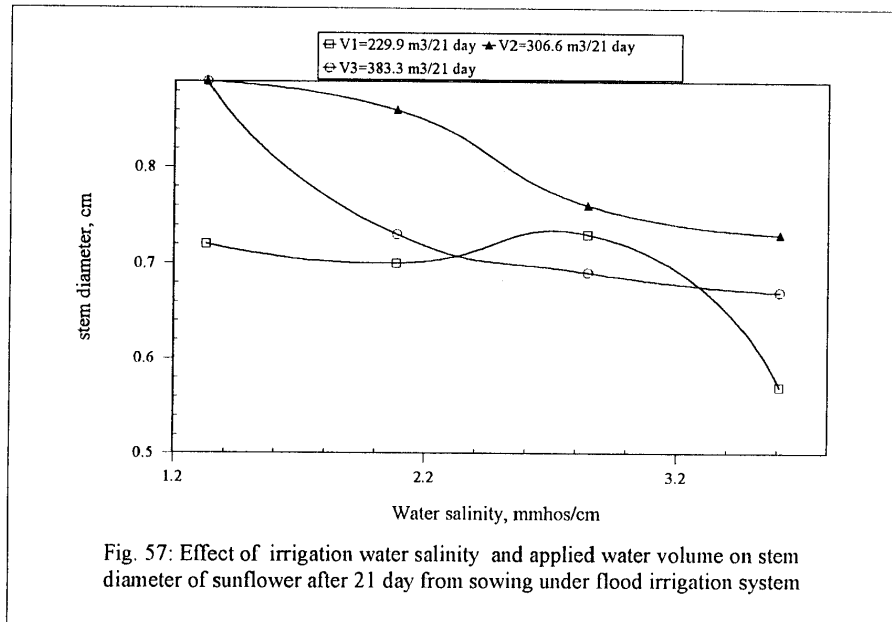
Data also revealed that under drip irrigation, plant height is taller compared to the flood irrigation. This finding may be due to high efficiency of drip irrigation in controlling water and fertilizer supply without any losses.

The maximum values of sunflower plant height of 305 cm, was obtained from the treatments that received canal water (EC of 1.33 mmhos/cm), and 1814.8 m<sup>3</sup>/season, of applied water under drip irrigation.

### **3.2.2. Stem diameter:**

The stem diameter of sunflower was affected by various irrigation water salinity treatments at all stages of growing season under both irrigation systems (drip and flood) as shown in tables from 29 to 34 in appendix and figures 57, 58 and from 59 to 62 in appendix, except at harvesting under drip irrigation, treatments do not show any significant effect on stem diameter. This may be due to high efficiency of drip irrigation in controlling water in the root zone.





Data presented in the same Tables and Figures showed that stem diameter of sunflower is high significantly affected by various amounts of applied water volume at all stages of growth under both irrigation systems (drip and flood).

Results also, revealed that the maximum value of sunflower stem diameter of 3.81 cm, was obtained from the treatments that received canal water (EC of 1.33 mmhos/cm), and 1814.8 m<sup>3</sup>/season, of applied water under drip irrigation

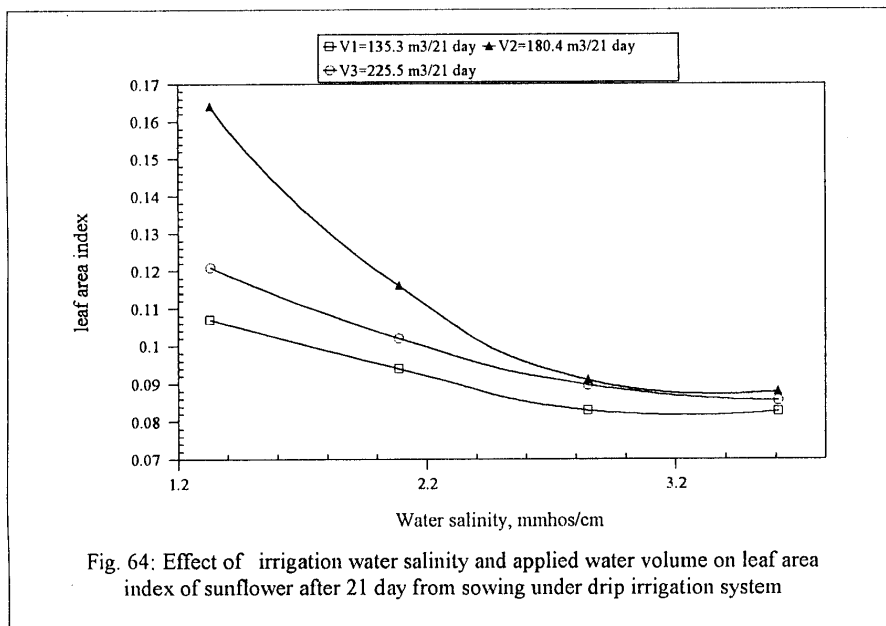
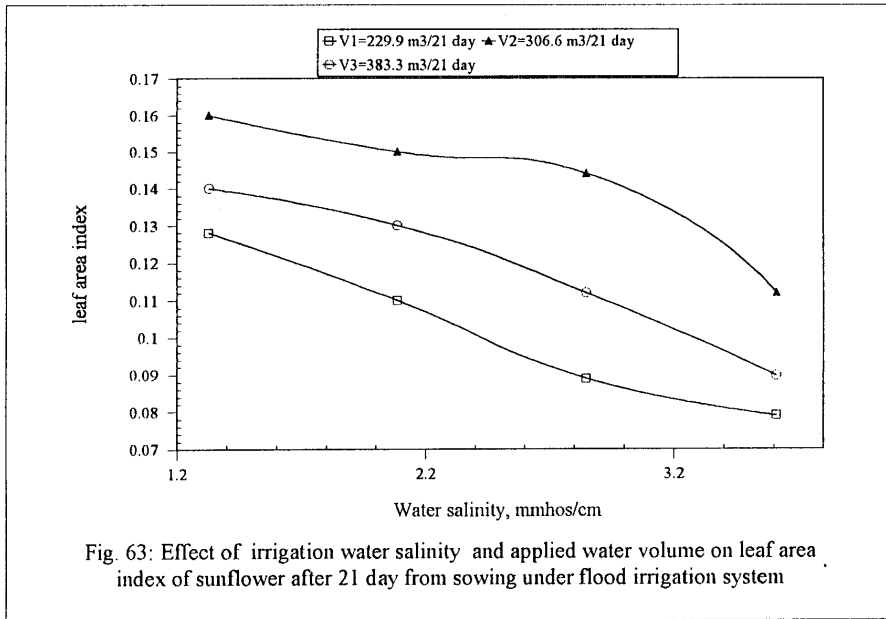
### **3.2.3. Leaf area index:**

Data presented in Tables from 35 to 38 in appendix and illustrated in Figs. 63, 64 and from 65 to 66 in appendix showed that irrigation water salinity had a highly significant effect on leaf area index at all stages of growing season under both irrigation systems (drip and flood).

In general, it can be reported that leaf area index decreased by using low water quality (EC of 3.61 mmhos/cm). This may be due to high osmotic pressure in the root zone. Therefore, water is not available for plants.

Data also showed that the leaf area index of sunflower is significantly affected by various amount of applied water volume at all stages of growing season, especially under flood irrigation system.

Data presented in the same tables and figures showed that the maximum leaf area index was obtained from flood irrigation system. The maximum value of leaf area index of sunflower of 2.04 was obtained from the treatment of received canal water (EC of 1.33 mmhos/cm), and 3855.6 m<sup>3</sup>/season, under flood irrigation at harvesting.



## **4. Crop yield of corn and sunflower:**

### **4.1. Corn crop yield:**

Data presented tables 39 and 40 in appendix and illustrated in Figs. 67 and 68 show that the water salinity treatments had a highly significant effect on corn crop yield under both irrigation systems (drip and flood). The values of corn yield were 4.960, 4.640, 4.370 and 3.870 Mg/fed under flood irrigation system and they were 5.414, 5.008, 4.561 and 4.252 Mg/fed under drip irrigation system by using water salinity levels of 1.33, 2.087, 2.85 and 3.61 mmhos/cm, respectively.

The average values of corn yield were 3.94, 4.464 and 4.968 Mg/fed, when amounts of applied water volume were 2066.4, 2755.2 and 3444 m<sup>3</sup>/season, respectively, under flood irrigation system. They were 4.419, 4.827 and 5.181 Mg/fed, when amounts of applied water volume were 1215.48, 1621.2 and 2029.44 m<sup>3</sup>/season, respectively, under drip irrigation system.

Drip irrigation system tends to increase the yield of corn by about 9.75% and save the irrigation water by about 41% compared to flood irrigation system. It can be reported that drip irrigation system is the best method for water management. This finding may be due to high efficiency of drip irrigation in providing the suitable amount of water and fertilizer to plant at different growth stages (Awady et al., 1975; El-Ebaby, 1986; El-Gindy, 1988; Bakr et al., 1979)

The maximum value of corn yield of 6.150 Mg/fed, was obtained by using canal water (EC of 1.33 mmhos/cm), as an irrigation water and 2029.44 m<sup>3</sup>/season, of applied water volume under drip irrigation system.

The minimum value of corn yield of 3.070 Mg/fed, was obtained by using a drainage water (EC of 3.61 mmhos/cm), as an irrigation water and 2066.4 m<sup>3</sup>/season, of applied water volume under flood irrigation system. Also, drip irrigation system gave the highest corn yield compared to flood irrigation system

especially in the treatments of saline irrigation water (drainage water which having salinity EC of 3.61 mmhos/cm), this can be attributed to the effect of drip irrigation system in controlling water and fertilizers supply (Badr, 1993)

Regression analysis was followed and the following multiple regression equation was developed to describe the relationship between the productivity of corn (Y) as affected by applied water volume ( $X_1$ ) and irrigation water salinity ( $X_2$ ) as follows:

Under drip irrigation the equation is

$$Y = 4.565 + 0.00093 X_1 - 0.515 X_2 \quad (R = 0.913)$$

As  $X_1$  ranged from 1215.48 to 2029.44 m<sup>3</sup>/fed/season and irrigation water salinity ranged from 1.33 to 3.61mmhos/cm.

Under flood irrigation the equation is

$$Y = 3.64 + 0.000725 X_1 - 0.475 X_2 \quad (R = 0.959)$$

As  $X_1$  ranged from 2066.4 to 3444 m<sup>3</sup>/fed/season and  $X_2$  ranged from 1.33 to 3.61mmhos/cm.

**Where**

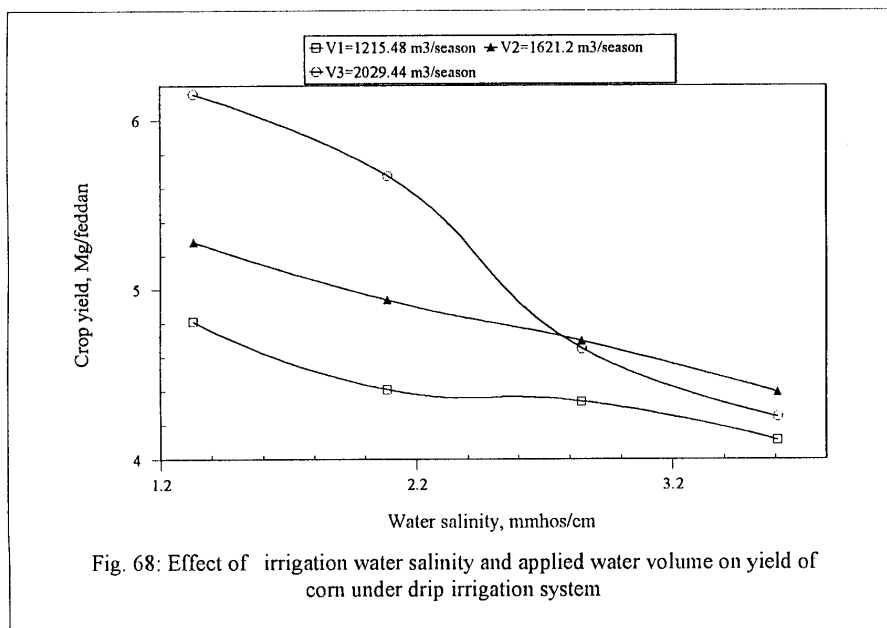
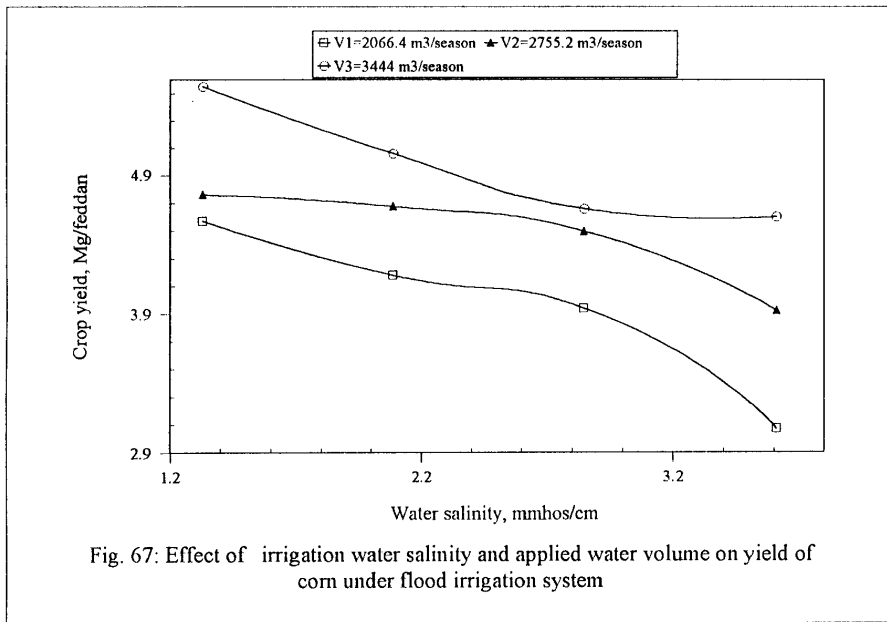
Y = corn crop yield

$X_1$  = The amount of applied water volume

$X_2$  = irrigation water salinity

R = correlation coefficient

Data presented in Tables 47 and 48 revealed that the difference between the measured values and predicted values of corn crop yield is low under both irrigation systems (flood and drip). The maximum residual percentages were 11.5 and 7.97% under flood and drip irrigation, respectively. The statical analysis revealed that, there is a highly correlation between corn crop yield and both irrigation water salinity and amount of applied water volume.



#### 4.2. Sunflower crop:

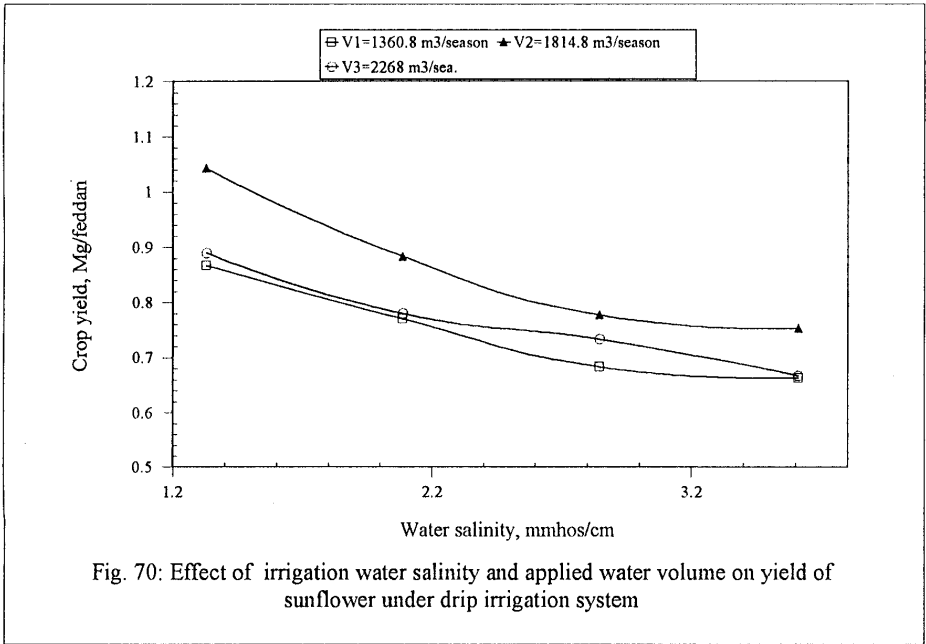
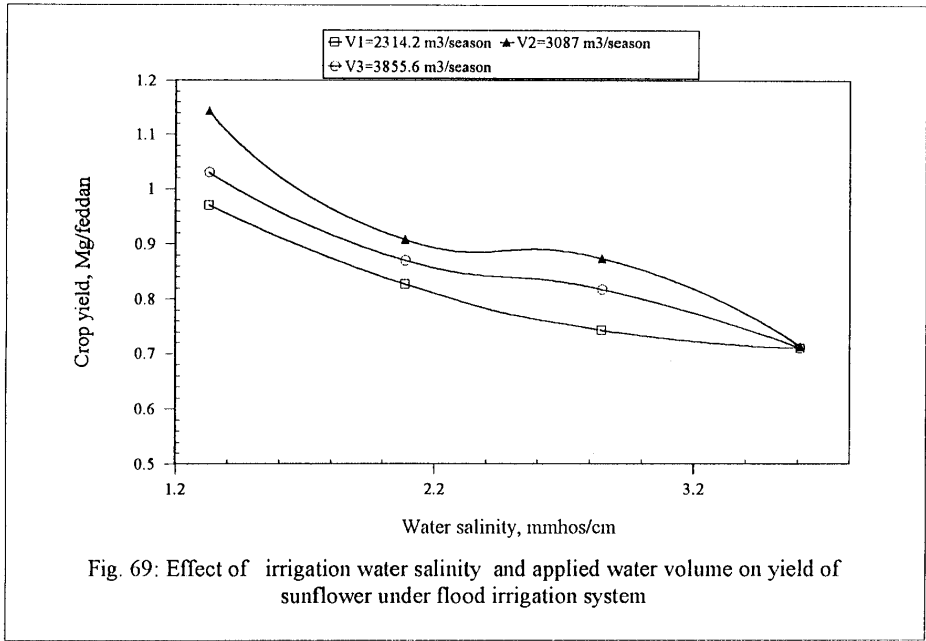
The water salinity had a highly significant effect on sunflower crop yield under both of irrigation systems (drip and flood) as shown in Tables 41 and 42 in the appendix, and illustrated in Figs 69 and 70. The average values of sunflower yield were 1.048, 0.868, 0.811 and 0.711 Mg/fed, under flood irrigation and were 0.910, 0.794, 0.731 and 0.661 Mg/fed, under drip irrigation system by using water salinity levels of 1.33, 2.087, 2.85 and 3.61 mmhos/cm, respectively.

Increasing applied water volume from 2314.2 to 3087 m<sup>3</sup>/season, tends to increase the sunflower yield by about 10.6%, and 5.13% when the amount of applied water volume increased from 2314.2 to 3855.6 m<sup>3</sup>/season, under flood irrigation system. Under drip irrigation, the increase in sunflower yield was about 20% when the amount of applied water increased from 1360.8 to 1814 m<sup>3</sup>/season, and about 11.14% when the amount of applied water increased from 1360.8 to 2268 m<sup>3</sup>/season.

The maximum value of sunflower yield was 1.143 Mg/fed by using 3087 m<sup>3</sup>/season, canal water (EC of 1.33 mmhos/cm), as irrigation water under flood irrigation system. The flood irrigation gave the highest yield of sunflower compared to drip irrigation, but the drip irrigation system saved about 41% of irrigation water.

In general, it can be reported that drip irrigation system is the best method for water management. This may be due to high efficiency of drip irrigation system in providing the suitable amount of water and fertilizers to plants at different growth stages (El-Ebaby, 1986; El-Gindy, 1988; Bakr et al., 1979).

Regression analysis was followed, and the following multiple regression equation was developed to describe the relationship between the productivity of





sunflower (Y) as affected by applied water volume ( $X_1$ ) and irrigation water salinity ( $X_2$ ) as follows:

Under drip irrigation the equation was

$$Y = 0.984 + 0.00063 X_1 - 0.1204 X_2 \quad (R = 0.858)$$

As  $X_1$  ranged from 1360.8 to 2268 m<sup>3</sup>/fed/season and  $X_2$  ranged from 1.33 to 3.61mmhos/cm.

Under flood irrigation the equation is

$$Y = 1.1113 + 0.0000298 X_1 - 0.138 X_2 \quad (R = 0.903)$$

As  $X_1$  ranged from 2314.2 to 3855.6 m<sup>3</sup>/fed/season and  $X_2$  ranged from 1.33 to 3.61mmhos/cm.

**Where**

Y = sunflower crop yield

$X_1$  = The amount of applied water volume

$X_2$  = irrigation water salinity

R = correlation coefficient

Data presented in Tables 49 and 50 revealed the difference between the measured values and predicted values of sunflower crop yield is low under both irrigation systems (flood and drip). The maximum residual percentages were 11.1 and 13.6 % under surface and drip irrigation, respectively. The statical analysis revealed that, there is a highly correlation between sunflower crop yield and both irrigation water salinity and amount of applied water volume under drip and flood irrigation.

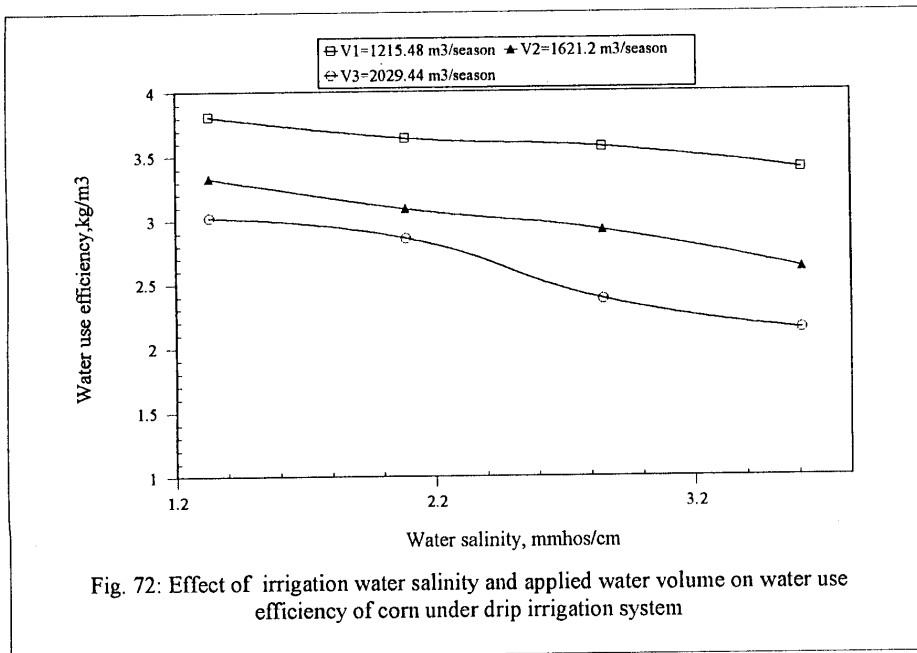
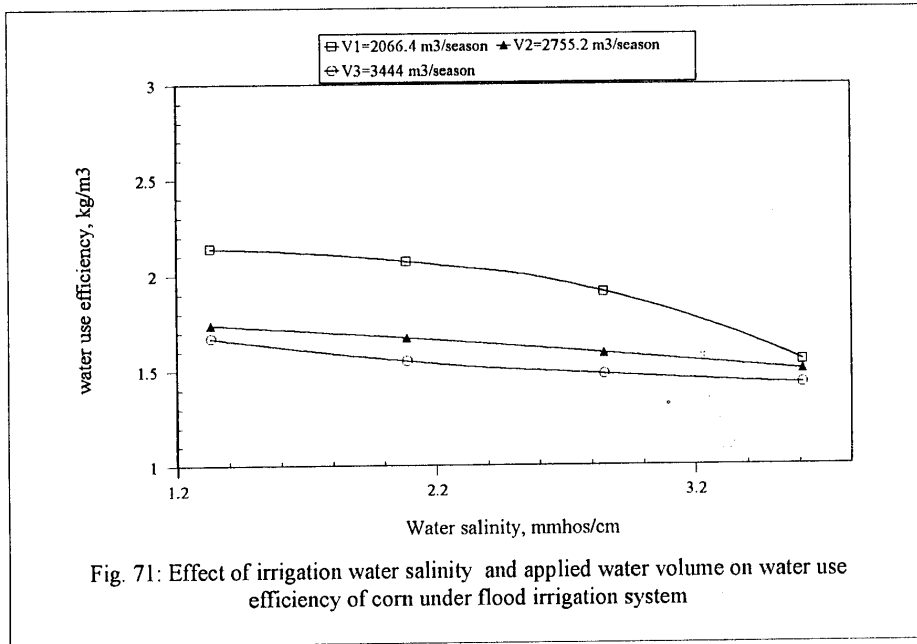
### **5. Water use efficiency (WUE) of corn and sunflower:**

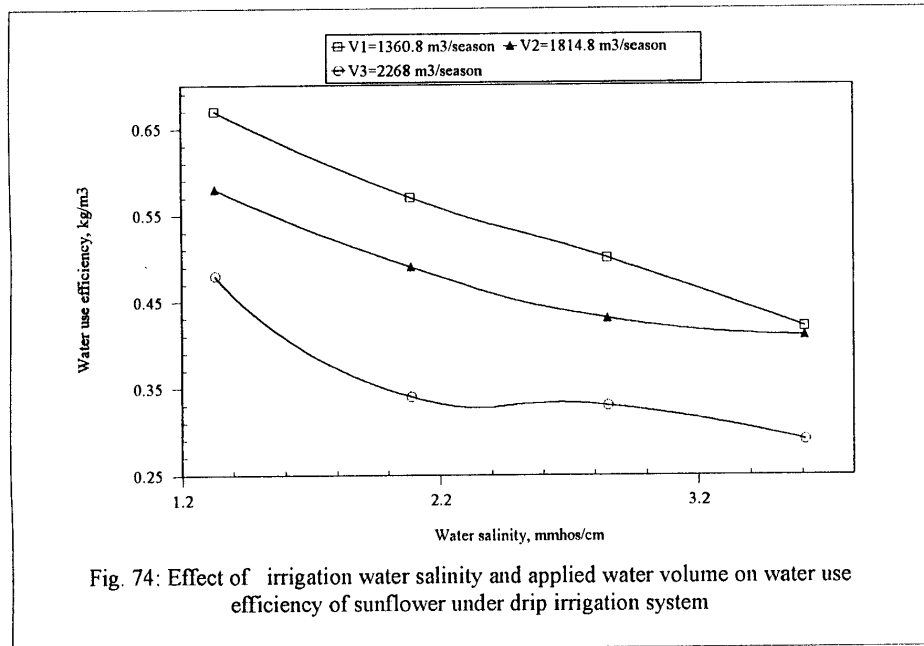
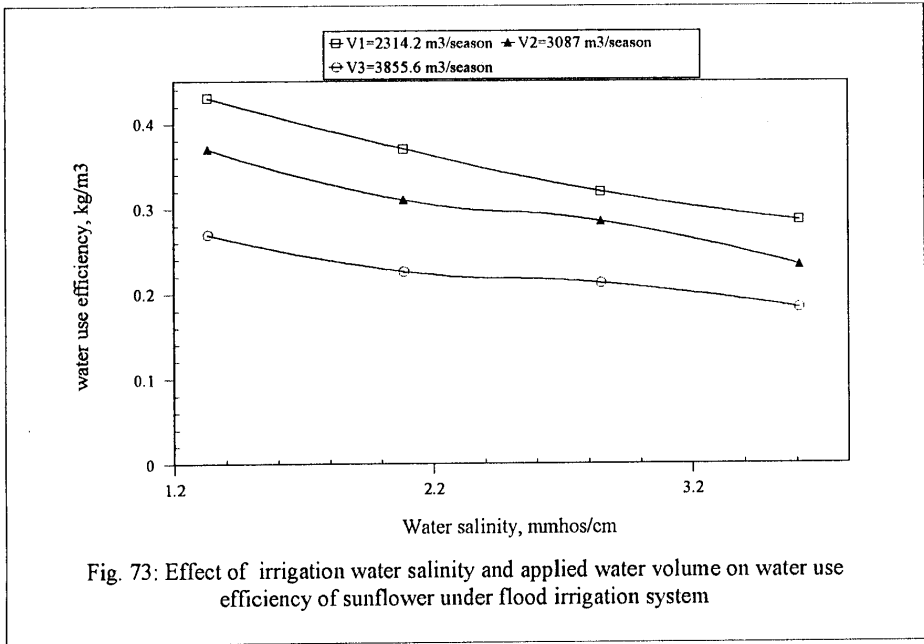
Water use efficiency is affected by many factors such as (irrigation water salinity, irrigation system, applied water volume and ...etc.

The values of water use efficiency (WUE) were affected by water salinity and applied water volume as shown in Tables 43, 44, 45 and 46 from appendix and Figures from 71 to 74. It decreased by increasing the salinity of irrigation water under both irrigation systems (drip and flood) for corn and sunflower crops, because the availability of water decreased with increasing of irrigation water salinity and causes raise in the osmotic potential in the root zone, therefore, the crop yield decreased.

The average values of water use efficiency for sunflower were 0.36, 0.30, 0.27 and 0.23 kg/m<sup>3</sup> under flood irrigation system and they were 0.58, 0.47, 0.42 and 0.37 kg/m<sup>3</sup> under drip irrigation system by using irrigation water salinity levels of 1.33, 2.087, 2.85 and 3.61 mmhos/cm, respectively. Also, the average values of water use efficiencies for corn were 1.85, 1.76, 1.66 and 1.49 kg/m<sup>3</sup> under flood irrigation system and they were 3.39, 3.29, 3.20 and 2.72 kg/m<sup>3</sup> under drip irrigation system by using irrigation water salinity levels of 1.33, 2.087, 2.85 and 3.61 mmhos/cm, respectively. Similar results were obtained by Mohamed (1995), who stated that water use efficiency of cucumber decreased by increasing irrigation water salinity.

Data revealed that the water use efficiency (WUE) decreased by increasing the amount of applied water volume for both crops (corn and sunflower) under both flood and drip irrigation systems. The obtained values of water use efficiency for corn were 1.92, 1.62 and 1.53 kg/m<sup>3</sup>, under flood irrigation by using 2066.4, 2755.2 and 3444 m<sup>3</sup>/season, of irrigation water and these values were 3.6, 2.99 and 2.6 kg/m<sup>3</sup>, under drip irrigation by using 1215.48, 1621.2, and 2029.44 m<sup>3</sup>/season, of irrigation water. The obtained values of water use efficiencies for sunflower were 0.35, 0.30, and 0.22 kg/m<sup>3</sup> under flood irrigation system by using 2314.2, 3087, and 3855.6 m<sup>3</sup>/season, irrigation water and they





were 0.54, 0.48, and 0.36 kg/m<sup>3</sup>, under drip irrigation by using 1360.8, 1814.82, and 2268 m<sup>3</sup>/season, of irrigation water.

The drip irrigation had a highly significant effect on water use efficiency compared to the flood irrigation. The water use efficiency increased by about 43.83 and 35.82 % for corn and sunflower crops, respectively, under drip irrigation compared to flood irrigation.

The maximum value of water use efficiency for corn of 3.81 kg/m<sup>3</sup> was obtained by using canal water (EC of 1.33 mmhos/cm), and 1215.48 m<sup>3</sup>/season, as an irrigation water under drip irrigation system. This value was 0.67 kg/m<sup>3</sup>, for sunflower crop by using 1360.8 m<sup>3</sup>/season, of canal water (EC of 1.33 mmhos/cm), as an irrigation water under drip irrigation, this finding was in agreement with (El-Gindy, 1984; Mohamed, 1995; El-Ebaby, 1986), they reported that drip irrigation system gave the highest value of water use efficiency compared to flood irrigation system.

Regression analysis was followed and the following multiple regression equation was developed to describe the relationship between the water use efficiency of corn and sunflower (Y) as affected by applied water volume (X<sub>1</sub>) and irrigation water salinity (X<sub>2</sub>) as follows:

#### 1- corn crop

Under drip irrigation the equation is

$$Y = 5.904 + 0.0013 X_1 - 0.295 X_2 \quad (R = 0.976)$$

As X<sub>1</sub> ranged from 1215.48 to 2029.44 m<sup>3</sup>/fed/season and irrigation water salinity ranged from 1.33 to 3.61mmhos/cm.

Under flood irrigation the equation is

$$Y = 3.065 + 0.00034 X_1 - 0.191 X_2 \quad (R = 0.815)$$

As  $X_1$  ranged from 2066.4 to 3444  $m^3$ /fed/season and irrigation water salinity ranged from 1.33 to 3.61mmhos/cm.

**Where:**

Y = The water use efficiency of corn

$X_1$  = The amount of applied water volume

$X_2$  = irrigation water salinity

R = correlation coefficient

Data presented in Tables 51 and 52 revealed that the difference between the measured values and predicted values of water use efficiency of corn is low under both irrigation system (flood and drip). The maximum residual percentages were 12.8 and 6.14% under flood and drip irrigation, respectively.

**2- Sunflower crop**

Under drip irrigation the equation is

$$Y = 1.047 + 0.00023 X_1 - 0.07 X_2 \quad (R = 0.971)$$

As  $X_1$  ranged from 1360.8 to 2268  $m^3$ /fed/season and irrigation water salinity ranged from 1.33 to 3.61mmhos/cm.

Under flood irrigation the equation is

$$Y = 0.6659 + 0.0000829 X_1 - 0.0497 X_2 \quad (R = 0.97)$$

As  $X_1$  ranged from 2314.2 to 3855.6  $m^3$ /fed/season and irrigation water salinity ranged from 1.33 to 3.61mmhos/cm.

**Where:**

Y = the water use efficiency of sunflower

$X_1$  = The amount of applied water volume

$X_2$  = irrigation water salinity

R = correlation coefficient

Data presented in Tables 53 and 54 revealed that the difference between the measured values and predicted values of water use efficiency of sunflower were low under both irrigation system (flood and drip). The maximum residual percentages were 7.69 and 11.7% under flood and drip irrigation, respectively. Statical analysis revealed that, there is a highly negative correlation between water use efficiency of both corn and sunflower and both irrigation water salinity and amount of applied irrigation water under both drip and flood irrigation

## **SUMMARY AND CONCLUSION**

Due to scarcity of fresh water at the end of canals. There is choice for the farmer to use another types of water for irrigation such as agricultural drainage water, which is available for him. Many areas use drainage water for irrigation such as El-Wady and Kafr El-Sheikh.

A field experiment was carried out during summer season of 1997 in North of El-Tahrir district, El-Bohaira Governorate. To study the individual and interaction effect of irrigation water salinity, irrigation systems and applied water volume on salt content and distribution of loamy sand soil, soil moisture content and distribution, crop yield, vegetative growth and water use efficiency of corn and sunflower crops.

The experiment was laid out in split plot design with three replicates. The experiment included the following factors:

### **Irrigation systems:**

There are two different irrigation systems as follows:

- 1- Flood irrigation
- 2- Drip irrigation

### **Applied water volume:**

Three different amounts of applied water volumes for two crops (corn and sunflower) under both irrigation systems (drip and surface) were used as follows:

Under flood irrigation, the amounts were 2066.4, 2755.2 and 3444 m<sup>3</sup>/season, for corn plant and they were 2314.2, 3087 and 3855.6 m<sup>3</sup>/season, for sunflower plant.



Under drip irrigation the amounts were 1215.48, 1621.2 and 2029.44 m<sup>3</sup>/season, for corn plant and they were 1360.8, 1814.82 and 2268 m<sup>3</sup>/season, for sunflower plant.

### **Water quality**

Four different water salinity levels were used in this research for both corn and sunflower as follows:

- 1-Fresh water (EC of 1.33 mmhos/cm)
- 2-Mixing water 2fresh water: 1drainage water (EC of 2.087 mmhos/cm)
- 3-Mixing water 2drainage water: 1fresh water (EC of 2.85 mmhos/cm)
- 4-drainage water (EC of 3.61 mmhos/cm)

The study included:

- 1-Before every irrigation, water samples were taken from canal and the nearest drain for chemical analysis.
- 2- Before starting the experiment, soil samples were taken at two different depths of 0-30 and 30-60 cm, from soil surface to determine different soil chemical and physical properties (soil moisture content and distribution, salt content and distribution, bulk density and pore size distribution).
- 3- Vegetative growth and crop yield measurements for corn and sunflower plants included plant height, leaf area, diameter of stem and grain yield.
- 4- At harvesting, soil samples were taken from four different depths 0, 15, 30 and 45 cm, to determine soil moisture content and salt content.

The obtained results could be summarized as follows:

### **1.Soil salinity distribution:**

The values of soil salinity (EC<sub>e</sub>) markedly increased with increasing the salinity of irrigation water. This increase takes vertical direction under flood irrigation system and this increase takes vertical and horizontal directions under drip irrigation system. Also, results obtained that soil

salinity ( $EC_e$ ) decreased by increasing the amount of applied water volume per season. In drip irrigation system the minimum value of salt concentration was found directly under emitters and increased when measured away far from emitters. Soil salinity under flood irrigation was higher than under drip irrigation in the root zone. Therefore, it can be reported that the use of drip irrigation controlled the salinity increase in the root zone.

## **2. Soil moisture content distribution:**

Generally soil moisture content decreased as soil depth increased after irrigation under flood irrigation, and it decreased as the soil depth increased and far away from the emitter under drip irrigation system. Soil moisture content increased by increasing the amount of applied water volume under both irrigation systems (drip and flood), therefore, soil wetted volume increased. Drip irrigation provides the soil with most favorable conditions of moisture content in the root zone, and provides the suitable amount of water requirements to the growing crops without any percolation losses comparing to surface irrigation.

## **3- vegetative growth:**

### **a- Corn plant:**

Results indicated that the maximum vegetative growth of corn was obtained in the plots, irrigated with canal water (low water salinity  $EC$  of 1.33 mmhos/cm), under drip irrigation. Also, it can be reported that irrigation with low water quality (drainage water  $EC$  of 3.61 mmhos/cm), has a high effect on decreasing plant height, stem diameter and leaf area index.

**b- Sunflower plant:**

Results also, indicated that the maximum plant height and stem diameter were found under drip irrigation but the maximum leaf area index was found under flood irrigation system. Also, results indicated that the maximum vegetative growth was obtained in the plots irrigated with low water salinity (canal water EC of 1.33 mmhos/cm).

**4.Crop yield:**

**a- Corn crop yield:**

The maximum value of corn yield of 6150 kg/fed was obtained in the plots, irrigated with low water salinity (canal water EC of 1.33 mmhos/cm), and received the highest amount of water of 2029.44 m<sup>3</sup>/season, under drip irrigation. Also, it is evident that although the drip irrigation saved about 41% of water requirements compared to surface one, the obtained corn yield was higher in the plots of drip irrigation comparing to the flood irrigation. Drip irrigation increased corn yield by 9.75% compared to flood irrigation.

**b- Sunflower crop yield:**

Results indicated that the maximum sunflower yield is obtained in the plots irrigated with good water quality (canal water EC of 1.33 mmhos/cm), and received the second amount of applied water volume 3087 m<sup>3</sup>/season, under flood irrigation. Also, it is evident that although the yield obtained from flood irrigated plots is higher than the drip one, the latter is the best method for water management. It saves about 41% from water requirement compared to the surface irrigation. Flood irrigation increased sunflower yield by 8.75% compared to drip irrigation.

### **5-Water use efficiency:**

The highest water use efficiencies of corn and sunflower of 3.81 and 0.67 Kg/m<sup>3</sup> were obtained from the treatments that received canal water irrigation (EC of 1.33 mmhos/cm), and lower amount of applied water volume under drip irrigation. Drip irrigation increased water use efficiency by 43.8 and 35.8% for corn and sunflower. Therefore, drip irrigation is the best considering water management, high corn yield, more water saved and high water use efficiency of corn and sunflower.

### **6- Applied recommendations:**

During summer season of 1997, the experiment was carried out in the North of El-Tahreer district. It can be recommended that.

- 1- Drainage water can be reused after mixing with canal water in that district.
- 2- If the farmer wants to plant corn, he will use drip irrigation because it gives the highest yield of corn comparing to flood irrigation. But, If he wants to plant sunflower, he will use flood irrigation because it gives the highest yield of sunflower comparing to drip irrigation.
- 3- If the farmer wants to plant corn and sunflower in this district, he will need applied water rates of 2029.45 and 3087 m<sup>3</sup>/season, respectively.
- 4- Drip irrigation in this case will save about 41% from water requirement comparing to flood irrigation.

## REFERENCES

- Abdel-Al, M.H. and M.M Syiam (1990). Effect of irrigation with saline water in two types of soil on growth, yield, yield components and fiber quality of Giza 75 cotton variety. *Agric. Res. Rev.*, 68 (6): 1155-1169.
- Abdel-Maksoud, S.E.; M.A.Hassan; M.S. El-Shal and E.E. Abdel-Aal (1992). Study on selecting the proper system of tomato-irrigation in new lands. *Misr J. Ag. Eng.*, 9 (3): 347-358.
- Abdel-Razek, A.A.; A.A. Wahdan; E.E. Kaoud and A.M. Abdel-Shafi (1992). Soil moisture and salt distribution patterns in clay soils as affected by different irrigation systems. *Egypt.J.Soil Sci.*, 32 (3): 343-360.
- Abdel-Sayed, S.M; Mona M. Shehata and A.M. Sorour (1993). Re-use of drainage water and its effect on soil salinity status under sugar beet. *Egypt. J.Agric. Res.*, 71 (3): 601-607.
- Abo-Soliman, M.S.M.; M.R. Khalifa; W.S. El-Sabry and K.M. Sayed (1992). Use of drainage water in irrigation at North of Nile Delta, its effects on soil salinity and wheat production. *J.Agric. Res., Tanta Univ.*, 18 (2): 425-435.
- Abou-Hadid, A.F.; A.S. El-Beltagy and H.M. El-Saeid (1988). Transpiration as affected by irrigation with saline water. *Egypt, J. Hort.*, 15 (2): 177-186.
- Alam, S.M. and S.A. Ali (1990). Effect of salinity on growth and nutrient content of bajra plant grown on desert and gravel. *Pakistan J. of Sci. and Ind. Res.*, 33 (5): 228-230.
- Al-Najium, M.A. and A.A. Neimmah (1989). The interactive effects of water quality and fertilizer levels on yield and quality of tomato lycmprsicion

- esculentum in sandy soil. *Journal of Agr. and Water Resources Res.*, 8 (1): 113-124.
- Aly, A.M. (1990). An evaluation study on the effect of drainage water on soil productivity and properties. Ph.D. Thesis, Soil Sci. Dept., Fac. of Agric., Ain shams Univ.
- Aly, S.M.; E.A. Mashaly and M. El-S. Mohamed (1995). Effect of irrigation with drainage water on soil properties, yield and fiber quality of two cotton cultivars. *Menofiya J. Agric. Res.*, 20 (6): 2379-2398.
- Amer, A.A.; S.A. Abdel-Wahab and M.A. Abou El-Soud (1997). Effect of water quality on soil salinity and some crops production. *J.Agric. Sci., Mansoura Univ.*, 22 (4): 1287-1295.
- Amer, M.H.; and H.J. van der zel (1983). The Egyptian-dutch Advisory Panel on land drainage: its activities and impact. Reprint of an article from the 1982 annual report of the Int. Inst. for Land Rec. and improvement with lists of panel publications. Ministry of Irrigation, Water Res. Center, Drainage Res. Inst.
- Attia, M.M.; A.M. Osman; M.A. Sayed and A.A. El-Kafory (1994<sub>a</sub>). Effect of irrigation intervals and plant density on sunflower yield in calcareous soil of west Nubaria Region. *J. Agric. Sci., Mansoura Univ.*, 19 (10): 3163-3168.
- Attia, M.M.; H.A. Agrama and H.E. Khalifa (1994<sub>b</sub>). Effect of irrigation intervals on yield of some corn varieties in calcareous soil of west Nubaria region. *J. Agric. Sci., Mansoura Univ.*, 19 (10): 3155-3162.
- Awady, M. N., G. W. Amerhom and M. S. Zaki (1975). Trickle irrigation trail on pea in conditions typical of Qalubia, *Ann. Ag. Sc., Moshtohor*, 4: 235-244.

- Ayars, J.E.; R.B.Hutmacher; R.A. Schoneman; S.S.vail and D.Felleke (1986). Drip irrigation of cotton with saline drainage water. *Trans. of the ASAE*, 29 (6): 1668-1673.
- Ayars, J.E.; R.B. Hutmacher; R.A. Schoneman and S.S. vail (1988). Managing saline irrigation water in arid areas with shallow saline groundwater. *Proc. Int. Conf. on Irrig. System Evaluation and Water Management, Wuham, china*: 1-12.
- Badr, A.E. (1980). Evaluation of drip irrigation system under Egyptian conditions. Ph. D. Thesis, Agric. Eng. Dept., Fac. of Agric., Cairo Univ.
- Badr, A.E. (1993) Production of some vegetables under drip and sprinkler irrigation systems. *Misr. J. Ag. Eng.*, 10 (2): 230-252.
- Bakr, M.A. and A.M. Shakshook (1977). A field trail to apply trickle, sprinkler and furrow irrigation to tomato plants on borg El-Arab calcareous soil. *J. Agric. Bes.*, 25: 343-350.
- Bakr,M.A. ; M.N. Hassan.; S. Marei and M.F.M. Ghanayem (1979). A comparison between drip, sprinkler and furrow irrigation systems on plant growth and salt distribution. *Egypt. J. Soil Sci.*, 19 (1): 31-39.
- Balba, A.M. and S.K. Atta (1981). Suitability and utilization of drainage waters for irrigation in El-Bahaira governorate. *Egypt .J. Soil Sci.*, 21 (3): 277-288.
- Barakat, M.A. (1996). Effect of irrigation with saline water on growth, yield and chemical constituents of potato under calcareous soil conditions. *Alex.J. Agric. Res.*, 41 (2): 389-397.

- Bernstein, L. and L.E. Francois (1973). Comparison of drip, furrow and sprinkler irrigation. *Soil Sci.*, 115 (1): 73-86.
- Black, C.A. (1965). *Methods of soil analysis. Part 1. Physical and Mineralogical properties, including statistics of measurements and sampling.* Amer. Soc. of Agron., Inc publ., Madison, Wisc., U.S.A: 213-377.
- Boland, A.M.; P.D. Mitchell and P.H. Jerie (1993). Effect of saline water combined with restricted irrigation on peach tree growth and water use. *Australian J. of Agr. Res.*, 44 (4): 799-816.
- Bucks, D.A; L.T. Erie; F.S. Nakayama and O.F. French (1974). Trickle irrigation management for grape. *Proc. 2<sup>nd</sup>. Inter Drip Irrig. Cong., San Diego, Cal., U.S.A.*: 503-507.
- Dutt, G.R.; D.A. pennington and F.J. Turner (1984). Irrigation as a solution to salinity problems of river basins. In: *salinity in water courses and reservoirs*, R.H. French (ed.). Ann Arbor Sci., 465-472.
- El-Ebaby, F.G. (1979). Evaluation of sprinkler irrigation under Egyptian condition. *M.Sc. Th., Agr. Eng. Dept., Fac. of Agric., Cairo Univ.*
- El-Ebaby, F.G. (1986). *Technology of irrigation for sandy soils.* Ph. D. Th., Agr. Eng. Dept., Fac. of Ag., Cairo Univ.
- El-Gindy, A.M. (1984). Optimization of water use for pepper crop. *Annals of Argic. Sci. Fac. of Agric., Ain-Shams Univ.*, 29 (1): 539-556.
- El-Gindy, A.M. (1988). Modern chemigation techniques for vegetable crops under Egyptian conditions. *Misr. J. Ag. Eng.*, 5 (1): 99-111.



- El-Kobia , T.; M.N. El-Awady ; A.M. El-Gindy and M. Hegazy (1986).  
Materials application through trickle irrigation system. *Misr. J.Agr. Eng.*, 3  
(3): 43-56.
- El-Leithi, A.A.; F.I. Zien and F.I. Headar (1990). Effect of drainage water reuse  
on the Micronutrient content and the yield of wheat plants. *J. Agric. Res.*,  
Tanta Univ., 16 (1): 141-149.
- El-Naggar, E.M.I. (1997). Consumptive use under drip irrigation system. M.Sc.  
Th., Soil Sci. Dept., Fac. of Agric., Ain Shams Univ.
- El-Nahal, M.A.; A.A. Abdel-Wahid, K.I. Noman and F.M. Howela (1983).  
Irrigation potential of drainage water in the Eastern Nile Delta region.  
*Egypt J. Soil Sci.*, 23 (2): 181-194.
- El-Nahal, M.A.; M.A. Barakat; W.M. El-Ghamry and M.E. Ibrahim (1979).  
Effect of soil kind, salinity of irrigation water and fertilization rate on  
cotton yield. *Agric. Res. Rev.*, 57 (4): 55-63.
- El-Saidi, M.T.; W.A. Hegazy; M. Kortam and H. El-Zein (1983). The use of  
saline water for irrigation and its effect on growth and yield of cotton  
plants. *Proc. 1 St Conf. Agro.*, Cairo, 100: 739.
- El-Shakweer, M.H.A. and M.A. Barakat (1984). Effect of salinity and sodium  
adsorption ratio of irrigation water on different varieties of Egyptian cotton.  
*Agr. Res. Rev.*, 62 (4a): 163-173.
- El-Shewikh, M.A.B. (1996). Effect of irrigation with drainage water on some soil  
characteristics and production of some field crops. M.Sc. Thesis, Soil Sci.  
Dept., Fac. of Agric., Mansoura Univ.

- El-Wakeel, A.F. and N.M. El-Mowelhi (1993). Reuse of drainage water on farm with reference to soil properties, crop production and heavy metal contents in plant tissues and dairy products. *Egypt J. Agric. Res.*, 71 (4): 845-861.
- Francois, L.E.; E.V. Mass T.J. Donovan and V.L. Youngs (1986). Effect of salinity on grain yield and quality, vegetative growth, and germination of semi-Dwarf and Durum wheat. *Agron. J.*, 78: 1053-1058.
- Francois, L.E.; T. Donovan and E.V. Mass (1984). Salinity effects on seed yield, growth and germination of grain sorghum. *Agron. J.*, 76: 741 - 744.
- Gerard, C.J. (1974). Drip and Furrow irrigation studies on sugar cane. 2<sup>nd</sup> int. Drip Irri., Congress, California, 329.
- Ghazy, A.; A.M. Selim and M.Z. Salem (1987). Effect of irrigation regime on the yield of wheat and the efficiency of water use. *Egypt. J. Soil Sci.*, 27 (3): 387-396.
- Groot, O.J. and D. Alexander (1979). Observation of soil water and salt movement under drip irrigation and flood irrigation in an apple orchard. *Soils and Fert.*, 42 (12): 8006.
- Hamdy, A. (1989). Salt accumulation and distribution in soil under different crops, water salinities and irrigation regimes. *Irrigazione-e-Drenaggio.*, 36 (4): 33- 37.
- Hamdy, A. (1992). Comparison study on the influence of irrigation with saline water using furrow and drip irrigation on tomato production and salt distribution in soils. *Proceedings 16<sup>th</sup> ICID European Regional Conference. Drought phenomena*, 1: 161-170.

- Ismail, S.N.; A. Abo-Gleil and M.E. El-Shal (1978). The suitability of drainage water of the main drains in Fayoum for irrigation purposes. Egypt J. Soil Sci., 18 (2): 181-189.
- Jackson, M.L. (1967). Soil chemical analysis. Prentice Hall India N. Y.
- Kandil, N.F. (1990). Effect of using drainage water on soil chemical, physical and hydrological properties on some soil of Egypt. Ph.D. Thesis, Soil Sci. Dept., Fac. of Agric., Cairo Univ.
- Kumar, R.; S.A.D. Sulieman and K. Larim (1985). Movement of salt and water under trickle irrigation and its field evaluation. Egypt. J. Soil Sci., 2 (2): 127-132.
- Kumar, V. and R.K. Sivanappan (1980). Salt distribution in drip irrigation. International Symposium on salt affected. Soil Symp. papers C.S.S.R.I., Karnal.
- Lin, S.S.M.; J.N. Hubbell and S.C.S. Tsou (1983). Drip irrigation and tomato yield under tropical conditions. Hortscience, 18 (4): 460-461.
- Lotfy, A.A.; M.M. Hussein and T.A. Nour (1987). Effect of salinity and vapor grade on growth and mineral constituents of cotton seedlings. Egypt. J. Soil Sci., 27 (1): 1-10.
- Mass, E.V. and G.J. Hoffman (1976). Crop salt tolerance current assessment. Proc. Int. Salinity Conf., Lub book, Tex.
- Mohamed, M.A. (1995). Some soil properties as affected by different irrigation conditions. Ph.D. Th., Soil Sci. Dept., Fac. of Agric., Ain Shams Univ.
- Moosa, K.F. (1976). The effect of salinity and moisture on suction power of cotton plants. M.Sc. Thesis, Soil Sci. Dept., Fac. Agric., Zagazig Univ.

- Mostafa, M.A.; E.M. Khaled; A.M. El-Sweedy and A.Sh. Abdel Nour (1992). The effect of irrigation water quality on some chemical properties of certain soils of Egypt. *Egypt J. Soil Sci.*, 32 (3): 391-406.
- Omar, M.S. and M.A. Aziz (1982). The use of saline irrigation waters, its effect on soil properties and plant growth. *Egypt. J. Soil Sci.*, 22 (1): 11-21.
- Paliwal, K.V. and G.L. Maliwal (1975). Effect of salts on the growth and mineral nutrition of cabbage (*Brassica oleraceq*) in soil and sand culture. *Proc., Indian Nat. Sci., A coid B*, 41 (2): 155-160.
- Rains D.W.; S. Goyal; R. Weyrauch and A. Lauchli (1987). Saline drainage water reuse in a cotton rotation system. *California Agriculture*, 41 (9/10): 24-26.
- Rathert, G. (1983). Effects of high salinity stress on mineral and carbohydrate metabolism of two cotton varieties. *Plant and soil*, 73: 247-256.
- Rhoades, J.D.; F.T.Bingham; J. Lety; P.J. Pinter; R.D. Lemert; W.J. Alves; G.J. Hoffman; J.A. Replogle; R.V. Swain and P.G. Pacheco (1988). Reuse of drainage water for irrigation: Results of Imperial valley studies, *Agricultural water management* (in press).
- Rhoades, J.D.; F.T.Bingham; J. Lety; P.J. Pinter; R.D. Lemert; W.J. Alves; G.J. Hoffman; J.A. Replogle; R.V. Swain and P.G. Pacheco (1988). Soil salinity and water balance. *Hilgardia*. 56 (5): 17-44.
- Richards, L.A. (1954). *Diagnosis and improvement of saline and alkali soils*. USDA, Handbook, 60.

- Rolston, D.E.; K.K. Tanji and D.W. Rains (1986). Saline drainage water reuse in the San Joaquin valley. Tech. Rep. WRCW-630 Cal. water resour. Ctr., Univ. of Cal. Riverside.
- Selem; M.M.; S.M. Abdel-Aziz, and F.S. Mustafa (1989). The use of drainage water for irrigation cotton. *Annals of Agric. Sci., Moshtohor*, 27 (3): 1917-1927.
- Sharma, D.P.; K.N. Singh; K.V. G.K. Roa and P.S. Kumbhare (1990). Reuse of saline drainage water for irrigation in sandy loam soil. Symposium on land drainage for salinity control in arid and semi arid regions, Cairo, Egypt. Feb. 25<sup>th</sup> to March 2<sup>nd</sup>, 3: 304-312.
- Sharma, D.P.; K.V.G.K. Rao; K.N. Singh; P.S. Kumbhare and R.J. Oastrbaan (1994). Conjunctive use of saline and non-saline irrigation waters in semi-arid regions. *Irrg. Sci.*, 15: 25-33.
- Shehata, A.A.; D.D. El-Badry and M. Hamdy (1983). Evaluating Drainage water quality in some Egyptian Governorates. *Egypt, J. Soil Sci.*, 23 (3): 211-224.
- Subba-Rao, N.; G.V. Subbaiah and B. Ramaiah 1987. Effect of saline water irrigation on tomato yield and soil property. *J. of Indian Soc. of Coastal Agr. Res.* 5 (2): 407-409.
- Talha, M. (1976). A comparison between two systems of irrigation on sunflower production. *Egypt. J. Soil Sci.*, 16 (1): 81-92.
- Van Hoorn, J.W. (1984). Drainage and salinity control for agricultural lands in Egypt. Use and management of saline water for irrigation training course, Cairo, March 24-April 19: 1-15.

West, D.W.; I.F. Merrigan; J.A.Taylor and G.M. Collins (1979). Soil salinity gradients and growth of tomato plants under drip irrigation. *Soil Sci.*, 127 (5): 281-291.

Younis, S.M. (1986). Study on different irrigation methods in western Nobarria to produce tomato. *Alex. J. Agric. Res.*, 31 (3): 11-19.

Zartman, R.E. and M. Gichuru (1984). Saline irrigation water: effects on soil chemical and physical properties. *Soil Sci.*, 138 (6): 417-422.

Table 7: Effect of applied water volume and irrigation water salinity on plant height of corn (cm) after 21 day from sowing under flood irrigation

Growth stage	Water salinity mmhos/cm	Applied water volume (m <sup>3</sup> /21day)			T- Mean
		374.8	499.8	624.7	
After 21 day from sowing	1.330	10.5	10.5	12.00	11.00
	2.087	10.4	10.5	10.13	10.34
	2.850	10.17	10.1	10.10	10.12
	3.61	10.0	9.80	10.00	10.43
	V-Mean	10.40	10.23	10.81	

LSD 5% = 0.85

LSD 1% = 1.16

Table 8: Effect of applied water volume and irrigation water salinity on plant height of corn (cm) after 50 day from sowing under flood irrigation

Growth stage	Water salinity mmhos/cm	Applied water volume (m <sup>3</sup> /50 day)			T- Mean
		1042.6	1390.2	1737.7	
After 50 day from sowing	1.330	65.83	67.30	74.70	69.28
	2.087	65.70	66.20	71.73	67.88
	2.850	61.70	63.40	67.20	64.10
	3.61	60.30	61.30	62.47	62.50
	V-Mean	63.38	64.60	69.86	

LSD 5% = 9.44

LSD 1% = 12.9

Table 9: Effect of applied water volume and irrigation water salinity on plant height of corn (cm) at harvesting under flood irrigation

Growth stage	Water salinity mmhos/cm	Applied water volume (m <sup>3</sup> /season)			T- Mean
		2066.4	2755.2	3444	
At harvesting	1.330	153	179	181	171
	2.087	147	170	177	160
	2.850	146	168	168	159
	3.61	141	157	163	154
	V-Mean	147	165	171	

LSD 5% = 18.75

LSD 1% = 25.69

Table 10: Effect of applied water volume and irrigation water salinity on plant height of corn (cm) after 21 day from sowing under drip irrigation

Growth stage	Water salinity mmhos/cm	Applied water volume (m <sup>3</sup> /21 day)			T- Mean
		220.5	294.0	367.5	
After 21 day from sowing	1.330	10.4	10.9	10.0	10.20
	2.087	9.70	10.5	10.1	10.33
	2.850	9.90	10.0	9.10	10.00
	3.61	9.60	8.00	9.00	9.030
	V-Mean	9.90	10.1	9.70	

LSD 5% = 0.94

LSD 1% = 1.28

Table 11: Effect of applied water volume and irrigation water salinity on plant height of corn (cm) after 50 day from sowing under drip irrigation

Growth stage	Water salinity mmhos/cm	Applied water volume (m <sup>3</sup> /50 day)			T- Mean
		613.3	817.8	1022.2	
After 50 day from sowing	1.330	76.8	103	99.4	93.1
	2.087	72.5	91.2	96.9	86.9
	2.850	70.1	79.4	95.3	81.6
	3.61	56.3	77.1	81.6	71.7
	V-Mean	68.9	87.7	93.3	

LSD 5% = 14.11

LSD 1% = 19.34

Table 12: Effect of applied water volume and irrigation water salinity on plant height of corn (cm) at harvesting under drip irrigation

Growth stage	Water salinity mmhos/cm	Applied water volume (m <sup>3</sup> /season)			T- Mean
		1215.5	1621.2	2029.4	
At harvesting	1.330	180	186	196	187
	2.087	176	187	190	184
	2.850	161	178	186	175
	3.61	158	164	175	166
	V-Mean	169	179	187	

LSD 5% = 24.4

LSD 1% = 33.4



Table 13: Effect of applied water volume and irrigation water salinity on stem diameter of corn (cm) after 21 day from sowing under flood irrigation

Growth stage	Water salinity mmhos/cm	Applied water volume (m <sup>3</sup> /21 day)			T- Mean
		374.8	499.8	624.7	
After 21 day from sowing	1.330	0.75	0.92	0.98	0.880
	2.087	0.70	0.80	0.76	0.750
	2.850	0.70	0.73	0.73	0.720
	3.61	0.66	0.73	0.69	0.773
	V-Mean	0.72	0.82	0.81	

LSD 5% = 0.127

LSD 1% = 0.174

Table 14: Effect of applied water volume and irrigation water salinity on stem diameter of corn (cm) after 50 day from sowing under flood irrigation

Growth stage	Water salinity mmhos/cm	Applied water volume (m <sup>3</sup> /season)			T- Mean
		1042.6	1390.2	1737.7	
After 50 day from sowing	1.330	1.96	1.80	1.99	1.87
	2.087	1.64	1.77	1.93	1.78
	2.850	1.42	1.58	1.80	1.60
	3.61	1.39	1.31	1.75	1.49
	V-Mean	1.60	1.62	1.84	

LSD 5% = 0.142

LSD 1% = 0.194

Table 15: Effect of applied water volume and irrigation water salinity on stem diameter of corn (cm) at harvesting under flood irrigation

Growth stage	Water salinity mmhos/cm	Applied water volume (m <sup>3</sup> /season)			T- Mean
		2066.4	2755.2	3444	
At harvesting	1.330	2.36	2.48	2.57	2.43
	2.087	2.30	2.43	2.46	2.40
	2.850	2.15	2.40	2.38	2.32
	3.61	2.05	2.15	2.21	2.14
	V-Mean	2.18	2.38	2.41	

LSD 5% = 0.27

LSD 1% = 0.37

Table 16: Effect of applied water volume and irrigation water salinity on stem diameter of corn (cm) after 21 day from sowing under drip irrigation

Growth stage	Water salinity mmhos/cm	Applied water volume (m <sup>3</sup> /21 day)			T- Mean
		220.5	294.0	367.5	
After 21 day from sowing	1.330	0.95	0.80	0.92	0.890
	2.087	0.92	0.73	0.90	0.793
	2.850	0.83	0.72	0.89	0.793
	3.61	0.80	0.70	0.67	0.753
	V-Mean	0.872	0.748	0.807	

LSD 5% = 0.142

LSD 1% = 0.195

Table 17: Effect of applied water volume and irrigation water salinity on stem diameter of corn (cm) after 50 day from sowing under drip irrigation

Growth stage	Water salinity mmhos/cm	Applied water volume (m <sup>3</sup> /50 day)			T- Mean
		613.3	817.8	1022.2	
After 50 day	1.330	1.23	2.66	2.5	2.13
	2.087	1.16	2.10	2.12	1.79
	2.850	1.16	1.93	1.99	1.73
	3.61	1.10	1.86	1.70	1.55
	V-Mean	2.19	2.14	2.18	

LSD 5% = 0.192

LSD 1% = 0.263

Table 18: Effect of applied water volume and irrigation water salinity on stem diameter of corn (cm) at harvesting under drip irrigation

Growth stage	Water salinity mmhos/cm	Applied water volume (m <sup>3</sup> /season)			T- Mean
		1215.5	1621.2	2029.4	
At harvesting	1.330	2.64	3.05	2.78	2.822
	2.087	2.50	2.73	2.73	2.653
	2.850	2.43	2.61	2.73	2.590
	3.61	2.22	2.54	2.32	2.362
	V-Mean	2.45	2.73	2.64	

LSD 5% = 0.29

LSD 1% = 0.39

Table 19: Effect of applied water volume and irrigation water salinity on leaf area index of corn after 21 day from sowing under flood irrigation

Growth stage	Water salinity mmhos/cm	Applied water volume (m <sup>3</sup> /21 day)			T- Mean
		374.8	499.8	624.7	
After 21 day from sowing	1.330	0.097	0.116	0.112	0.108
	2.087	0.075	0.092	0.085	0.084
	2.850	0.070	0.090	0.073	0.078
	3.61	0.067	0.077	0.072	0.072
	V-Mean	0.077	0.094	0.085	

LSD 5% = 0.034

LSD 1% = 0.046

Table 20: Effect of applied water volume and irrigation water salinity on leaf area index of corn at harvesting under flood irrigation

Growth stage	Water salinity mmhos/cm	Applied water volume (m <sup>3</sup> /season)			T- Mean
		2066.4	2755.2	3444	
At harvesting	1.330	1.62	1.68	1.91	1.74
	2.087	1.476	1.52	1.77	1.59
	2.850	1.480	1.39	1.75	1.54
	3.61	1.270	1.26	1.50	1.34
	V-Mean	1.462	1.463	1.73	

LSD 5% = 0.126

LSD 1% = 0.173

Table 21: Effect of applied water volume and irrigation water salinity on leaf area index of corn after 21 day from sowing under drip irrigation

Growth stage	Water salinity mmhos/cm	Applied water volume (m <sup>3</sup> /21 day)			T- Mean
		220.5	294.0	367.5	
After 21 day from sowing	1.330	0.106	0.117	0.122	0.115
	2.087	0.095	0.112	0.113	0.107
	2.850	0.089	0.105	0.093	0.096
	3.61	0.060	0.061	0.073	0.065
	V-Mean	0.087	0.099	0.100	

LSD 5% = 0.01

LSD 1% = 0.013

Table 22: Effect of applied water volume and irrigation water salinity on leaf area index of corn at harvesting under drip irrigation

Growth stage	Water salinity mmhos/cm	Applied water volume (m <sup>3</sup> /season)			T- Mean
		1215.5	1621.2	2029.4	
At harvesting	1.330	1.80	1.87	2.01	1.890
	2.087	1.538	1.74	1.88	1.720
	2.850	1.54	1.48	1.83	1.620
	3.61	1.41	1.34	1.38	1.377
	V-Mean	1.570	1.610	1.775	

LSD 5% = 0.363

LSD 1% = 0.498

Table 23: Effect of applied water volume and irrigation water salinity on plant height of sunflower (cm) after 21 day from sowing under flood irrigation

Growth stage	Water salinity mmhos/cm	Applied water volume (m <sup>3</sup> /21 day)			T- Mean
		229.9	306.6	383.3	
After 21 day from sowing	1.330	15.0	21.1	19.0	18.4
	2.087	14.5	18.2	17.1	15.9
	2.850	13.0	16.5	16.7	15.9
	3.61	12.0	17.1	14.0	14.7
	V-Mean	13.63	18.46	16.60	

LSD 5% = 2.8

LSD 1% = 3.84

Table 24: Effect of applied water volume and irrigation water salinity on plant height of sunflower (cm) after 50 day from sowing under flood irrigation

Growth stage	Water salinity mmhos/cm	Applied water volume (m <sup>3</sup> /50 day)			T- Mean
		932.4	1243.2	1554	
After 50 day from sowing	1.330	124.2	184.3	172.8	160.4
	2.087	121.7	180.5	159.2	153.8
	2.850	115.1	176.1	144.0	145.1
	3.61	113.1	171.8	142.2	142.4
	V-Mean	118.53	178.20	154.60	

LSD 5% = 13.5

LSD 1% = 18.5

Table 25: Effect of applied water volume and irrigation water salinity on plant height of sunflower (cm) at harvesting under flood irrigation

Growth stage	Water salinity mmhos/cm	Applied water volume (m <sup>3</sup> /season)			T- Mean
		2314.2	3087.0	3855.6	
At harvesting	1.330	260	276	285	265
	2.087	251	270	274	262
	2.850	248	268	249	255
	3.61	237	263	242	247
	V-Mean	249	261	263	

LSD 5% = 27.93

LSD 1% = 33.27

Table 26: Effect of applied water volume and irrigation water salinity on plant height of sunflower (cm) after 21 day from sowing under drip irrigation

Growth stage	Water salinity mmhos/cm	Applied water volume (m <sup>3</sup> /21 day)			T- Mean
		135.3	180.4	225.5	
After 21 day from sowing	1.330	17.0	21.5	17.90	18.80
	2.087	16.7	18.5	17.60	17.57
	2.850	16.4	17.9	17.50	16.98
	3.61	16.0	18.1	17.53	17.38
	V-Mean	16.66	18.77	17.61	

LSD 5% = 0.66

LSD 1% = 0.90

Table 27: Effect of applied water volume and irrigation water salinity on plant height of sunflower (cm) after 50 day from sowing under drip irrigation

Growth stage	Water salinity mmhos/cm	Applied water volume (m <sup>3</sup> /50 day)			T- Mean
		548.5	731.3	914.1	
After 50 day from sowing	1.330	142.1	191.6	178.3	170.7
	2.087	138.2	179.1	175.6	164.3
	2.850	133.3	175.4	170.9	159.9
	3.61	130.6	172.7	165.4	156.2
	V-Mean	136.05	179.70	172.60	

LSD 5% = 22.5

LSD 1% = 30.8

Table 28: Effect of applied water volume and irrigation water salinity on plant height of sunflower (cm) at harvesting under drip irrigation

Growth stage	Water salinity mmhos/cm	Applied water volume (m <sup>3</sup> /season)			T- Mean
		1360.8	1814.8	2268.0	
At harvesting	1.330	267	305	289	287
	2.087	187	303	170	220
	2.850	156	285	166	202
	3.61	140	284	143	189
	V-Mean	187.5	294.5	192.2	

LSD 5% = 17.43

LSD 1% = 23.9

Table 29: Effect of applied water volume and irrigation water salinity on stem diameter of sunflower (cm) after 21 day from sowing under flood irrigation

Growth stage	Water salinity mmhos/cm	Applied water volume (m <sup>3</sup> /21 day)			T- Mean
		229.9	306.6	383.3	
After 21 day from sowing	1.330	0.72	0.89	0.89	0.817
	2.087	0.70	0.86	0.73	0.763
	2.850	0.73	0.76	0.69	0.727
	3.61	0.57	0.73	0.67	0.658
	V-Mean	0.67	0.81	0.75	

LSD 5% = 0.081

LSD 1% = 0.111

Table 30: Effect of applied water volume and irrigation water salinity on stem diameter of sunflower (cm) after 50 day from sowing under flood irrigation

Growth stage	Water salinity mmhos/cm	Applied water volume (m <sup>3</sup> /50 day)			T- Mean
		932.4	1243.2	1554	
After 50 day from sowing	1.330	2.04	2.60	2.64	2.430
	2.087	2.01	2.51	2.29	2.300
	2.850	1.97	2.39	2.25	2.203
	3.61	1.81	2.23	1.85	1.998
	V-Mean	1.98	2.45	2.26	

LSD 5% = 0.157

LSD 1% = 0.215

Table 31: Effect of applied water volume and irrigation water salinity on stem diameter of sunflower (cm) at harvesting under flood irrigation

Growth stage	Water salinity mmhos/cm	Applied water volume (m <sup>3</sup> /season)			T- Mean
		2314.2	3087.0	3855.6	
At harvesting	1.330	2.91	3.68	3.30	3.30
	2.087	2.73	3.42	3.21	3.12
	2.850	2.62	3.39	3.23	3.08
	3.61	2.34	3.18	2.98	2.83
	V-Mean	2.65	3.42	3.18	

LSD 5% = 0.447

LSD 1% = 0.612

Table 32: Effect of applied water volume and irrigation water salinity on stem diameter of sunflower (cm) after 21 day from sowing under drip irrigation

Growth stage	Water salinity mmhos/cm	Applied water volume (m <sup>3</sup> /21 day)			T- Mean
		135.3	180.4	225.5	
After 21 day from sowing	1.330	0.83	0.95	0.88	0.870
	2.087	0.82	0.89	0.86	0.857
	2.850	0.68	0.80	0.76	0.730
	3.61	0.73	0.86	0.70	0.783
	V-Mean	0.765	0.875	0.788	

LSD 5% = 0.095

LSD 1% = 0.130

Table 33: Effect of applied water volume and irrigation water salinity on stem diameter of sunflower (cm) after 50 day from sowing under drip irrigation

Growth stage	Water salinity mmhos/cm	Applied water volume (m <sup>3</sup> /50 day)			T- Mean
		548.5	731.3	914.1	
After 50 day from sowing	1.330	2.32	2.78	2.39	2.497
	2.087	2.23	2.58	2.35	2.387
	2.850	1.97	2.32	2.27	2.190
	3.61	1.88	2.23	2.26	2.197
	V-Mean	2.16	2.48	2.32	

LSD 5% = 0.136

LSD 1% = 0.186

Table 34: Effect of applied water volume and irrigation water salinity on stem diameter of sunflower (cm) at harvesting under drip irrigation

Growth stage	Water salinity mmhos/cm	Applied water volume (m <sup>3</sup> /season)			T- Mean
		1360.8	1814.8	2268.0	
At harvesting	1.330	2.91	3.81	3.12	3.28
	2.087	2.81	3.30	2.99	2.97
	2.850	2.74	3.13	2.99	2.95
	3.61	2.73	3.10	2.91	2.91
	V-Mean	2.76	3.33	3.00	

LSD 5% = 0.543

LSD 1% = 0.744



Table 35: Effect of applied water volume and irrigation water salinity on leaf area index of sunflower after 21 day from sowing under flood irrigation

Growth stage	Water salinity mmhos/cm	Applied water volume (m <sup>3</sup> /21 day)			T- Mean
		229.9	306.6	383.3	
After 21 day from sowing	1.330	0.128	0.160	0.140	0.143
	2.087	0.110	0.150	0.130	0.130
	2.850	0.089	0.144	0.112	0.115
	3.61	0.079	0.112	0.0897	0.094
	V-Mean	0.102	0.142	0.118	

LSD 5% = 0.009

LSD 1% = 0.013

Table 36: Effect of applied water volume and irrigation water salinity on leaf area index of sunflower at harvesting under flood irrigation

Growth stage	Water salinity mmhos/cm	Applied water volume (m <sup>3</sup> /season)			T- Mean
		2314.2	3087.0	3855.6	
At harvesting	1.330	2.09	1.92	2.403	2.140
	2.087	2.05	1.91	2.230	2.063
	2.850	2.07	1.76	2.200	2.010
	3.61	1.58	1.64	1.890	1.700
	V-Mean	1.95	1.81	2.18	

LSD 5% = 0.128

LSD 1% = 0.176

Table 37: Effect of applied water volume and irrigation water salinity on leaf area index of sunflower after 21 day from sowing under drip irrigation

Growth stage	Water salinity mmhos/cm	Applied water volume (m <sup>3</sup> /21 day)			T- Mean
		135.3	180.4	225.5	
After 21 day from sowing	1.330	0.107	0.164	0.121	0.131
	2.087	0.094	0.116	0.102	0.104
	2.850	0.083	0.091	0.0897	0.088
	3.61	0.0828	0.088	0.0856	0.085
	V-Mean	0.092	0.115	0.0996	

LSD 5% = 0.011

LSD 1% = 0.015

Table 38: Effect of applied water volume and irrigation water salinity on leaf area index of sunflower at harvesting under drip irrigation

Growth stage	Water salinity mmhos/cm	Applied water volume (m <sup>3</sup> /season)			T- Mean
		1360.8	1814.8	2268.0	
At harvesting	1.330	2.27	2.36	2.33	2.32
	2.087	1.94	2.16	2.24	2.11
	2.850	1.88	1.87	2.31	2.02
	3.61	1.65	1.69	1.74	1.69
	V-Mean	1.935	2.020	2.155	

LSD 5% = 0.286

LSD 1% = 0.392

Table 39: Effect of applied water volume and irrigation water salinity on yield of corn (Mg/fed) under flood system

Irrigation system	Water salinity mmhos/cm	Applied water volume (m <sup>3</sup> /season)			T- Mean
		2066.4	2755.2	3444	
Flood irrigation	1.330	4.570	4.760	5.550	4.960
	2.087	4.180	4.680	5.060	4.640
	2.850	3.940	4.500	4.660	4.370
	3.61	3.070	3.920	4.603	3.870
	V-Mean	3.940	4.464	4.968	

LSD 5% = 0.272

LSD 1% = 0.372

Table 40: Effect of applied water volume and irrigation water salinity on yield of corn (Mg/fed) under drip system

Irrigation system	Water salinity mmhos/cm	Applied water volume (m <sup>3</sup> /season)			T- Mean
		1215.5	1621.2	2029.4	
Drip irrigation	1.330	4.810	5.283	6.150	5.414
	2.087	4.413	4.937	5.673	5.008
	2.850	4.340	4.693	4.650	4.561
	3.61	4.113	4.393	4.250	4.252
	V-Mean	4.419	4.827	5.181	

LSD 5% = 0.260

LSD 1% = 0.360

Table 41: Effect of applied water volume and irrigation water salinity on yield of sunflower (Mg/fed) under flood irrigation system

Irrigation system	Water salinity mmhos/cm	Applied water volume (m <sup>3</sup> /season)			T- Mean
		2314.2	3087.0	3855.6	
Flood irrigation	1.330	0.970	1.143	1.030	1.048
	2.087	0.827	0.907	0.870	0.868
	2.850	0.743	0.873	0.817	0.811
	3.61	0.710	0.713	0.710	0.711
	V-Mean	0.813	0.909	0.857	

LSD 5% = 0.084

LSD 1% = 0.115

Table 42: Effect of applied water volume and irrigation water salinity on yield of sunflower (Mg/fed) under drip irrigation system

Irrigation system	Water salinity mmhos/cm	Applied water volume (m <sup>3</sup> /season)			T- Mean
		1360.8	1814.8	2268.0	
Drip irrigation	1.330	0.867	1.043	0.890	0.910
	2.087	0.770	0.883	0.780	0.794
	2.850	0.683	0.777	0.733	0.731
	3.61	0.663	0.753	0.667	0.661
	V-Mean	0.691	0.864	0.768	

LSD 5% = 0.077

LSD 1% = 0.106

Table 43: Effect of applied water volume and irrigation water salinity on water use efficiency of corn ( $\text{kg}/\text{m}^3$ ) under flood irrigation system

Irrigation system	Water salinity mmhos/cm	Applied water volume ( $\text{m}^3/\text{season}$ )			T- Mean
		2066.4	2755.2	3444	
Flood irrigation	1.330	2.14	1.74	1.67	1.85
	2.087	2.07	1.67	1.55	1.76
	2.850	1.91	1.59	1.48	1.66
	3.61	1.55	1.50	1.43	1.49
	V-Mean	1.92	1.62	1.53	

LSD 5% = 0.098

LSD 1% = 0.135

Table 44: Effect of applied water volume and irrigation water salinity on water use efficiency of corn ( $\text{kg}/\text{m}^3$ ) under drip irrigation system

Irrigation system	Water salinity mmhos/cm	Applied water volume ( $\text{m}^3/\text{season}$ )			T- Mean
		1215.5	1621.2	2029.4	
Drip irrigation	1.330	3.81	3.33	3.02	3.39
	2.087	3.64	3.09	2.86	3.29
	2.850	3.57	2.92	2.38	3.20
	3.61	3.40	2.62	2.14	2.72
	V-Mean	3.60	2.99	2.60	

LSD 5% = 0.59

LSD 1% = 0.81

Table 45: Effect of applied water volume and irrigation water salinity on water use efficiency of sunflower ( $\text{kg/m}^3$ ) under flood irrigation system

Irrigation system	Water salinity mmhos/cm	Applied water volume ( $\text{m}^3/\text{season}$ )			T- Mean
		2314.2	3087.0	3855.6	
Flood irrigation	1.330	0.43	0.37	0.27	0.36
	2.087	0.37	0.31	0.23	0.30
	2.850	0.32	0.285	0.21	0.27
	3.61	0.286	0.233	0.18	0.23
	V-Mean	0.35	0.30	0.22	

LSD 5% = 0.031

LSD 1% = 0.043

Table 46: Effect of applied water volume and irrigation water salinity on water use efficiency of sunflower ( $\text{kg/m}^3$ ) under drip irrigation system

Irrigation system	Water salinity mmhos/cm	Applied water volume ( $\text{m}^3/\text{season}$ )			T- Mean
		1360.8	1814.8	2268.0	
Drip irrigation	1.330	0.67	0.58	0.48	0.58
	2.087	0.57	0.49	0.34	0.47
	2.850	0.50	0.43	0.33	0.42
	3.61	0.42	0.41	0.29	0.37
	V-Mean	0.54	0.48	0.36	

LSD 5% = 0.0335

LSD 1% = 0.046

Table 47: Predicted and measured values of corn crop yield under flood irrigation system.

$$Y = 3.64 + 0.000725X_1 - 0.475X_2 \quad R = 0.959$$

Volumes m <sup>3</sup> /fed/season	Water salinity mmhos/cm	Y <sub>predicted</sub> kg/fed	Y <sub>measured</sub> kg/fed	Residual percentage %
2066.4	1.330	4.506	4.571	1.42
	2.087	4.147	4.303	3.60
	2.850	3.780	3.938	4.01
	3.610	3.420	3.067	11.5
2755.2	1.330	5.010	4.760	5.25
	2.087	4.650	4.676	0.55
	2.850	4.280	4.490	4.68
	3.610	3.920	3.920	0.00
3444	1.330	5.510	5.550	0.72
	2.087	5.150	5.062	1.74
	2.850	4.780	4.659	2.60
	3.610	4.420	4.604	3.99

Table 48: Predicted and measured values of corn crop yield under drip irrigation system.

$$Y = 4.655 + 0.00093X_1 - 0.515X_2 \quad R = 0.913$$

Volumes m <sup>3</sup> /fed/season	Water salinity mmhos/cm	Y <sub>predicted</sub> kg/fed	Y <sub>measured</sub> kg/fed	Residual percentage %
1215.48	1.330	5.010	4.810	4.16
	2.087	4.620	4.410	4.76
	2.850	4.230	4.340	2.53
	3.610	3.840	4.113	6.64
1621.2	1.330	5.390	5.281	2.06
	2.087	4.999	4.937	1.26
	2.850	4.610	4.694	1.79
	3.610	4.210	4.394	4.19
2029.44	1.330	5.770	6.145	6.10
	2.087	5.380	5.672	5.15
	2.850	4.990	4.650	7.31
	3.610	4.590	4.251	7.97

Table 49: Predicted and measured values of sunflower crop yield under flood irrigation system.

$$Y = 1.1113 + 0.0000298X_1 - 0.138X_2 \quad R = 0.903$$

Volumes m <sup>3</sup> /fed/season	Water salinity mmhos/cm	Y <sub>predicted</sub> kg/fed	Y <sub>measured</sub> kg/fed	Residual percentage %
2314.2	1.330	0.996	0.973	3.36
	2.087	0.892	0.824	8.25
	2.850	0.787	0.740	6.35
	3.610	0.682	0.710	3.94
3087.0	1.330	1.019	1.140	10.6
	2.087	0.915	0.910	0.55
	2.850	0.809	0.910	11.1
	3.610	0.705	0.720	2.08
3855.6	1.330	1.042	1.030	1.16
	2.087	0.938	0.870	7.82
	2.850	0.833	0.820	1.59
	3.610	0.728	0.710	2.53

Table 50: Predicted and measured values of sunflower crop yield under drip irrigation system.

$$Y = 0.984 + 0.00063X_1 - 0.1204X_2 \quad R = 0.858$$

Volumes m <sup>3</sup> /fed/season	Water salinity mmhos/cm	Y <sub>predicted</sub> kg/fed	Y <sub>measured</sub> kg/fed	Residual percentage %
1361	1.330	0.909	0.898	1.22
	2.087	0.818	0.720	13.6
	2.850	0.727	0.680	6.90
	3.610	0.635	0.660	3.79
1814.8	1.330	0.938	1.060	11.5
	2.087	0.847	0.880	3.75
	2.850	0.755	0.780	3.21
	3.610	0.664	0.750	11.5
2268	1.330	0.967	0.980	1.32
	2.087	0.875	0.780	12.17
	2.850	0.784	0.760	3.15
	3.610	0.692	0.666	3.90



Table 51: Predicted and measured values of water use efficiency of corn under flood irrigation system.

$$Y = 3.065 + 0.00034X_1 - 0.191X_2 \quad R = 0.815$$

Volumes m <sup>3</sup> /fed/season	Water salinity mmhos/cm	Y <sub>predicted</sub> kg/fed	Y <sub>measured</sub> kg/fed	Residual percentage %
2066.4	1.330	2.11	2.21	4.52
	2.087	1.96	2.07	5.31
	2.850	1.82	1.90	4.21
	3.610	1.67	1.48	12.8
2755.2	1.330	1.87	1.73	8.10
	2.087	1.73	1.69	2.37
	2.850	1.58	1.62	2.47
	3.610	1.44	1.42	1.40
3444	1.330	1.64	1.62	1.23
	2.087	1.50	1.48	1.35
	2.850	1.35	1.36	0.73
	3.610	1.20	1.33	9.80

Table 52: Predicted and measured values of water use efficiency of corn under drip irrigation system.

$$Y = 5.904 + 0.0013X_1 - 0.295X_2 \quad R = 0.976$$

Volumes m <sup>3</sup> /fed/season	Water salinity mmhos/cm	Y <sub>predicted</sub> kg/fed	Y <sub>measured</sub> kg/fed	Residual percentage %
1215.48	1.330	3.93	3.90	0.77
	2.087	3.70	3.62	2.21
	2.850	3.48	3.57	2.52
	3.610	3.25	3.38	3.85
1621.2	1.330	3.40	3.26	4.29
	2.087	3.18	3.05	4.26
	2.850	2.95	2.90	1.72
	3.610	2.73	2.71	0.74
2029.44	1.330	2.87	3.02	4.97
	2.087	2.65	2.81	5.69
	2.850	2.42	2.28	6.14
	3.610	2.20	2.09	5.26

Table 53: Predicted and measured values of water use efficiency of sunflower under flood irrigation system.

$$Y = 0.6659 + 0.0000829X_1 - 0.0497X_2 \quad R = 0.97$$

Volumes m <sup>3</sup> /fed/season	Water salinity mmhos/cm	Y <sub>predicted</sub> kg/fed	Y <sub>measured</sub> kg/fed	Residual percentage %
2314.2	1.330	0.410	0.430	4.65
	2.087	0.370	0.355	4.22
	2.850	0.330	0.320	3.12
	3.610	0.295	0.286	3.15
3087.0	1.330	0.344	0.370	7.03
	2.087	0.306	0.286	6.99
	2.850	0.268	0.290	7.58
	3.610	0.231	0.233	0.86
3855.6	1.330	0.280	0.260	7.69
	2.087	0.243	0.230	5.65
	2.850	0.205	0.210	2.38
	3.610	0.167	0.180	7.22

Table 54: Predicted and measured values of water use efficiency of sunflower under drip irrigation system.

$$Y = 1.047 + 0.00023X_1 - 0.07X_2 \quad R = 0.971$$

Volumes m <sup>3</sup> /fed/season	Water salinity mmhos/cm	Y <sub>predicted</sub> kg/fed	Y <sub>measured</sub> kg/fed	Residual percentage %
1361.0	1.330	0.640	0.670	4.48
	2.087	0.588	0.580	1.38
	2.850	0.534	0.500	6.80
	3.610	0.481	0.440	9.30
1814.8	1.330	0.536	0.580	7.59
	2.087	0.483	0.480	0.63
	2.850	0.430	0.430	0.00
	3.610	0.377	0.410	8.05
2268.0	1.330	0.432	0.430	0.46
	2.087	0.380	0.340	11.7
	2.850	0.326	0.330	1.21
	3.610	0.273	0.290	5.86

Table 55: Regression equations which describe change of salt content in the soil for corn and sunflower crops under flood and drip irrigation systems

$$Y = av^2 + bv + ct^2 + dt$$

Irrigation system	Crop	a	b	c	d	R	R <sup>2</sup>
Surface	Corn	4.44E-7	-0.0032	-0.409	3.930	0.935	0.87
	Sunflower	4.76E-07	-0.0036	-0.529	4.510	0.960	0.920
Drip	Corn	-1E-06	0.0017	-0.0534	0.804	0.930	0.860
	Sunflower	-1.9E-07	-0.00038	-0.254	1.860	0.940	0.880

Table 56: Predicted and measured values of salt content change for corn and sunflower under surface and drip irrigation systems

Crop	Irrigation system	Volumes, m <sup>3</sup> /season	Water salinity, mmhos/cm							
			1.330		2.087		2.850		3.610	
			M	P	M	P	M	P	M	P
corn	Surface	2066.4	-0.55	-0.21	1.22	1.70	3.80	3.16	4.88	4.14
		2755.2	-0.84	-0.94	0.78	0.97	0.70	2.43	3.18	3.41
		3444.0	-1.26	-1.25	0.61	0.67	1.99	2.12	2.50	3.10
	Drip	1215.5	1.68	1.56	2.30	2.03	2.54	2.44	2.96	2.79
		1621.2	1.27	1.10	0.90	1.57	1.46	1.98	2.07	2.33
		2029.4	0.12	0.31	0.91	0.77	1.27	1.19	1.60	1.53
Sunflower	Surface	2314.2	-1.02	-0.72	1.28	1.32	3.44	2.77	4.41	3.61
		2087.0	-1.20	-1.51	0.33	0.53	1.00	1.98	2.70	2.81
		3855.6	-1.32	-1.74	1.10	0.30	1.67	1.75	2.42	2.58
	Drip	1360.8	1.21	1.16	1.32	1.90	2.33	2.37	2.75	2.55
		1814.8	0.75	0.71	1.14	1.46	1.42	1.92	1.93	2.09
		2268.0	0.19	0.19	1.19	0.94	1.36	1.40	1.77	1.57

M, measured value of salt content change  
P, predicted value of salt content change

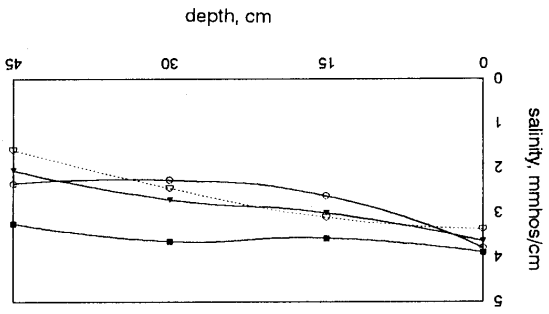


Fig. 5. Effect of applied water volume on salt content at 2.85 mmhos/cm, irrigation water salinity under flood irrigation for corn.

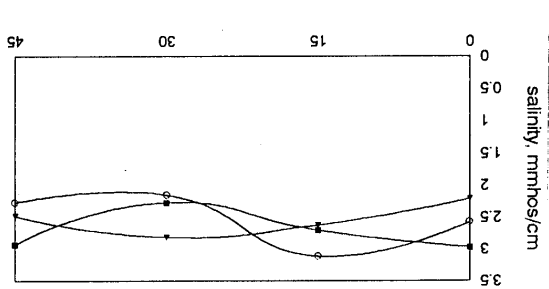
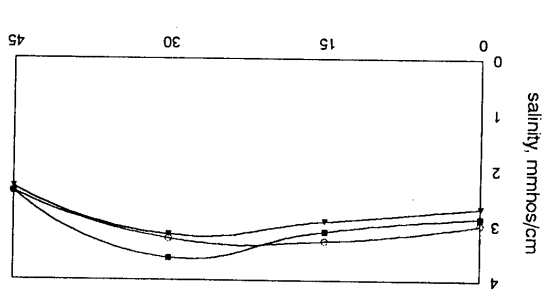
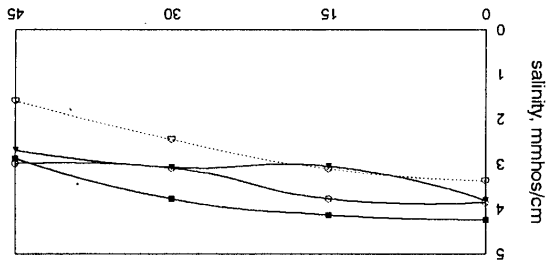
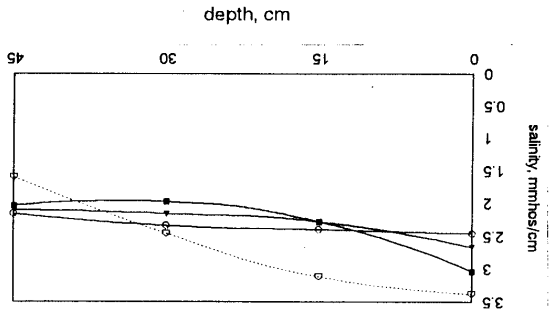


Fig. 6. Effect of applied water volume on salt content at 3.61 mmhos/cm, irrigation water salinity under flood irrigation for corn.



\* 2066.4 m<sup>3</sup>/season    \* 2755.2 m<sup>3</sup>/season  
 + 3444 m<sup>3</sup>/season

\* 2066.4 m<sup>3</sup>/season    \* 2755.2 m<sup>3</sup>/season  
 + 3444 m<sup>3</sup>/season



+ 2066.4 m<sup>3</sup>/season    + 2755.2 m<sup>3</sup>/season  
 + 3444 m<sup>3</sup>/season

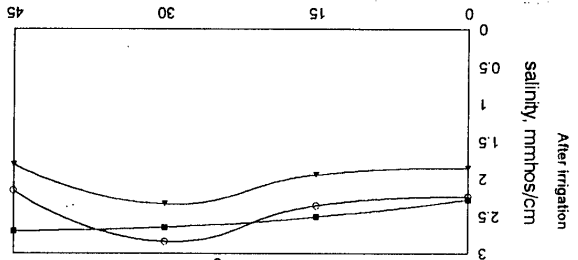
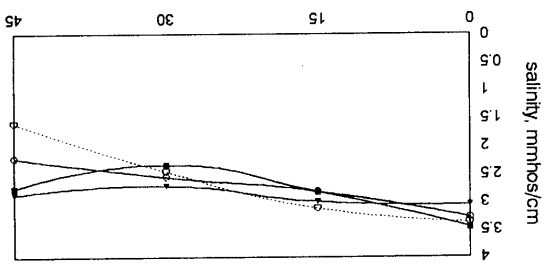


Fig. 7. Effect of applied water volume on salt content at 1.33 mmhos/cm, irrigation water salinity under flood irrigation for sunflower.



+ 2066.4 m<sup>3</sup>/season    + 2755.2 m<sup>3</sup>/season  
 + 3444 m<sup>3</sup>/season

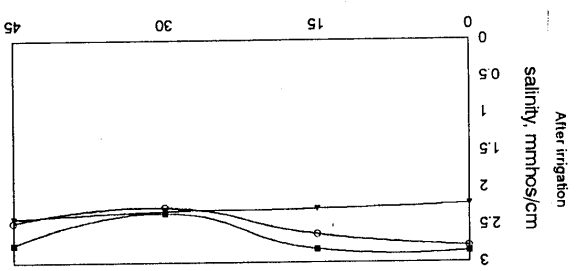


Fig. 8. Effect of applied water volume on salt content at 2.087 mmhos/cm, irrigation water salinity under flood irrigation for sunflower.

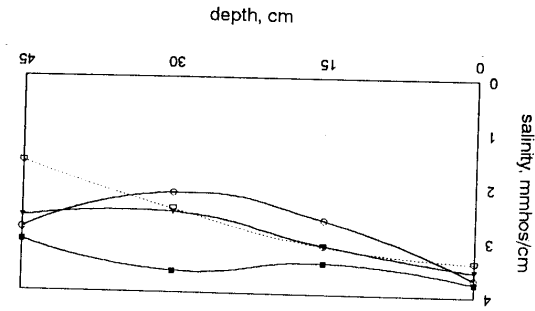


Fig. 9. Effect of applied water volume on salt content at 2.85 mmhos/cm, irrigation water salinity under flood irrigation for sunflower.

○ 2314.2 m<sup>3</sup>/season  
 □ 3855.6 m<sup>3</sup>/season  
 ◻ 3087 m<sup>3</sup>/season

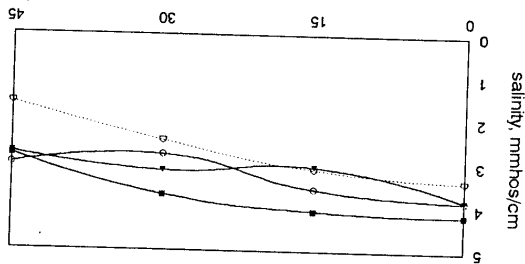
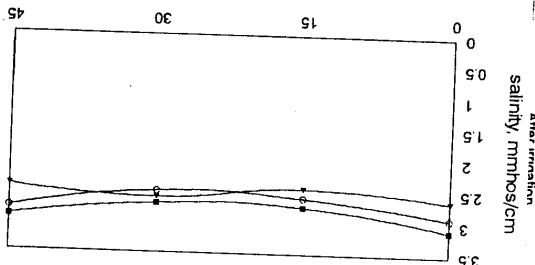
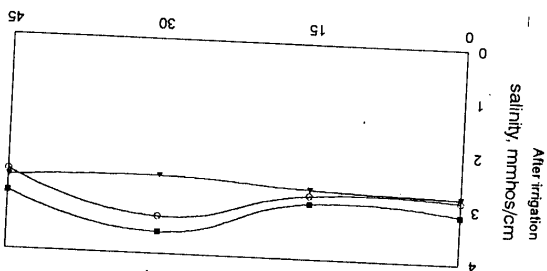


Fig. 10. Effect of applied water volume on salt content at 3.61 mmhos/cm, irrigation water salinity under flood irrigation for sunflower.

○ 2314.2 m<sup>3</sup>/season  
 □ 3855.6 m<sup>3</sup>/season  
 ◻ 3087 m<sup>3</sup>/season



Along lateral

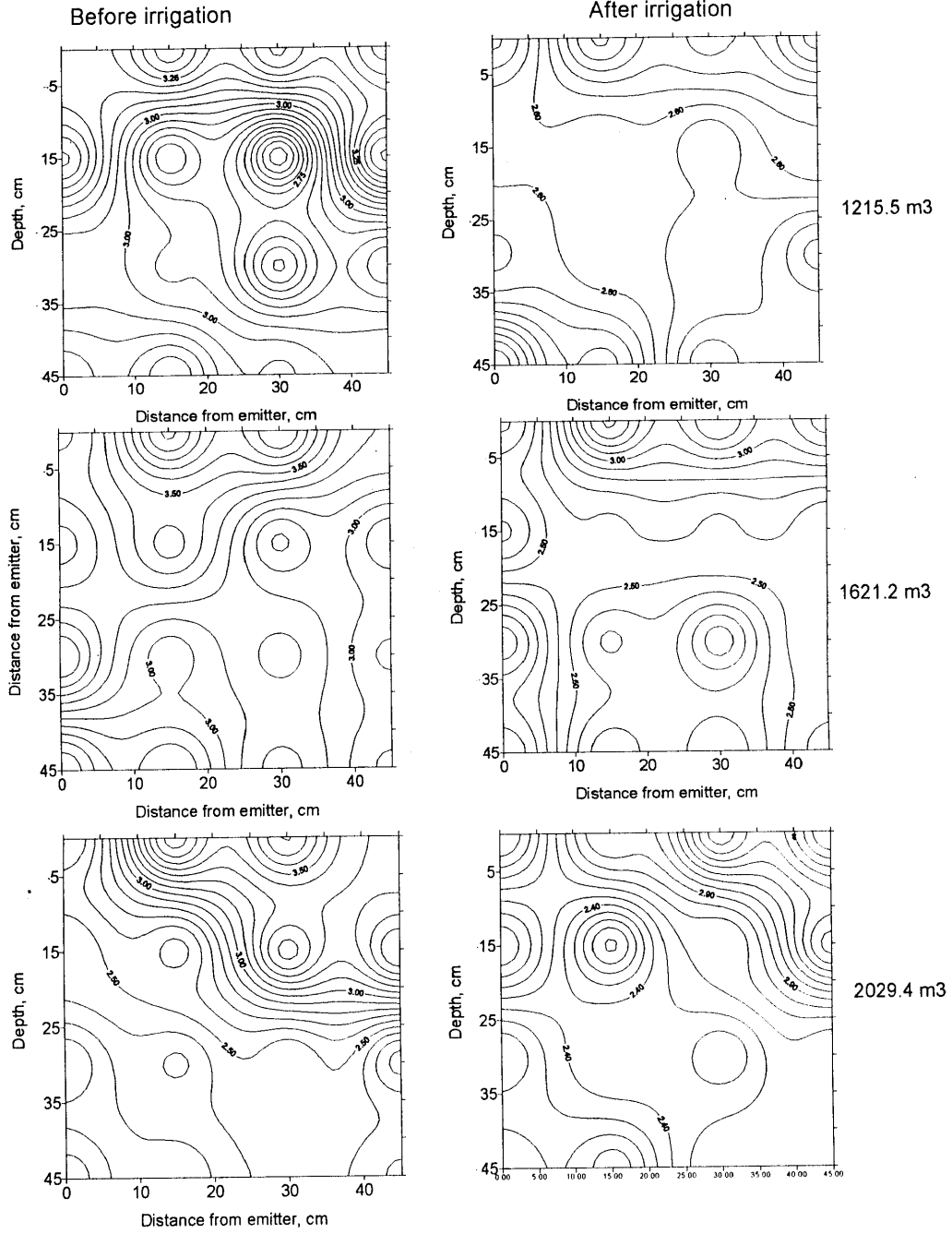


Fig.11-b: Salt content and distribution as affected by applied water volume under drip irrigation at 1.33 mmhos/cm irrigation water salinity for corn

Across lateral

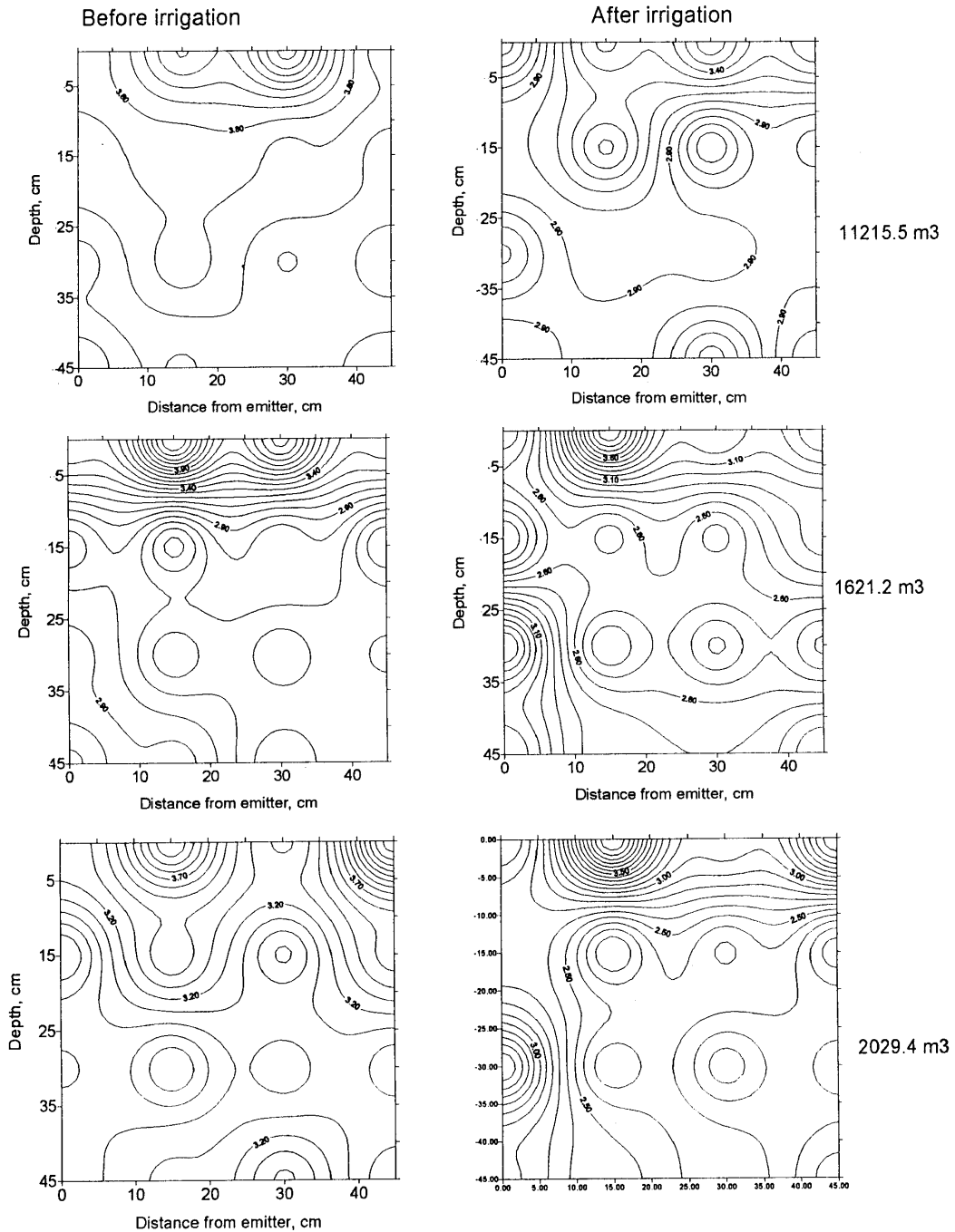


Fig.12-a: Salt content and distribution as affected by applied water volume under drip

irrigation at 2.087 mmhos/cm irrigation water salinity for corn



Along lateral

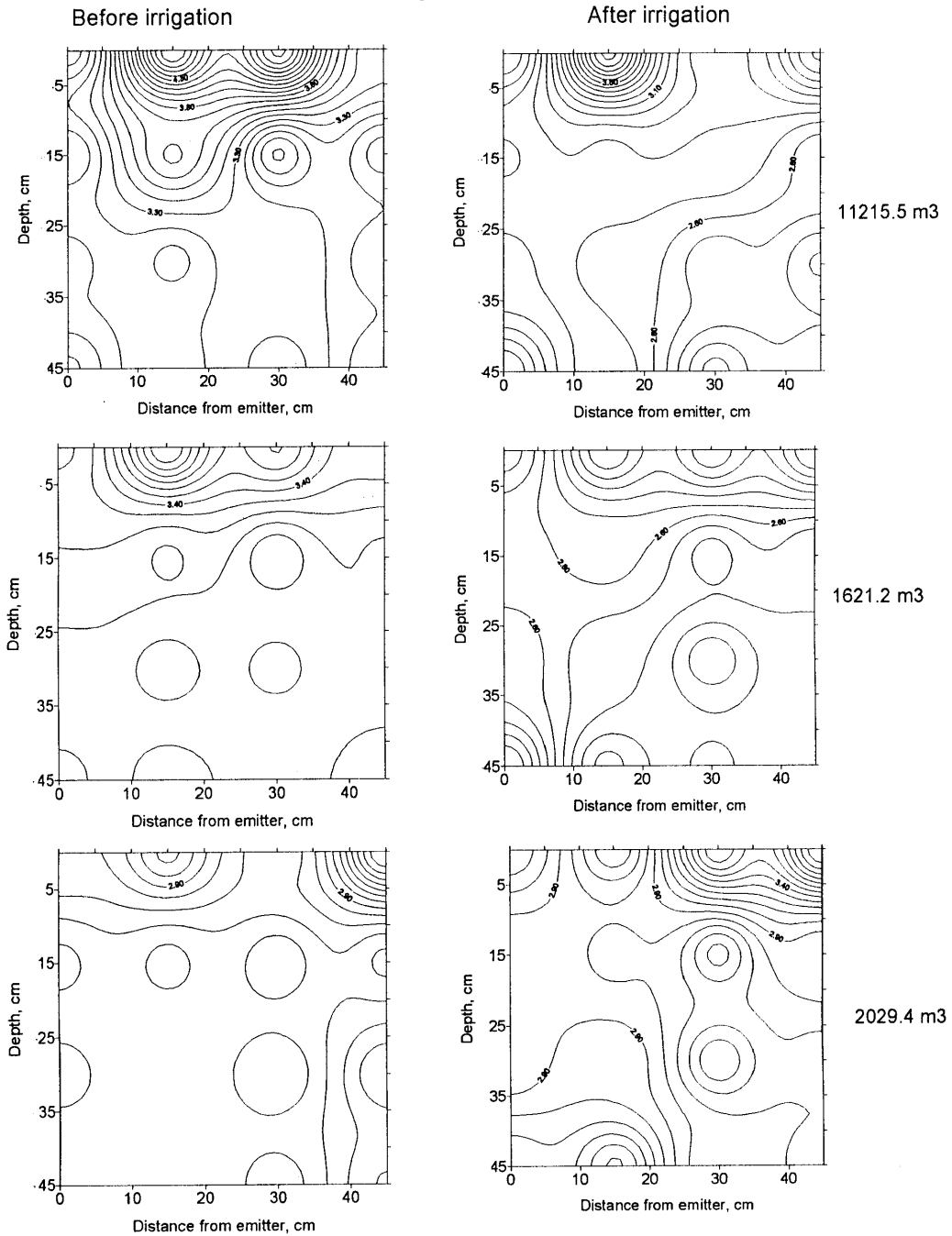


Fig.12-b: Salt content and distribution as affected by applied water volume under drip irrigation at 2.087 mmhos/cm irrigation water salinity for corn

Across lateral

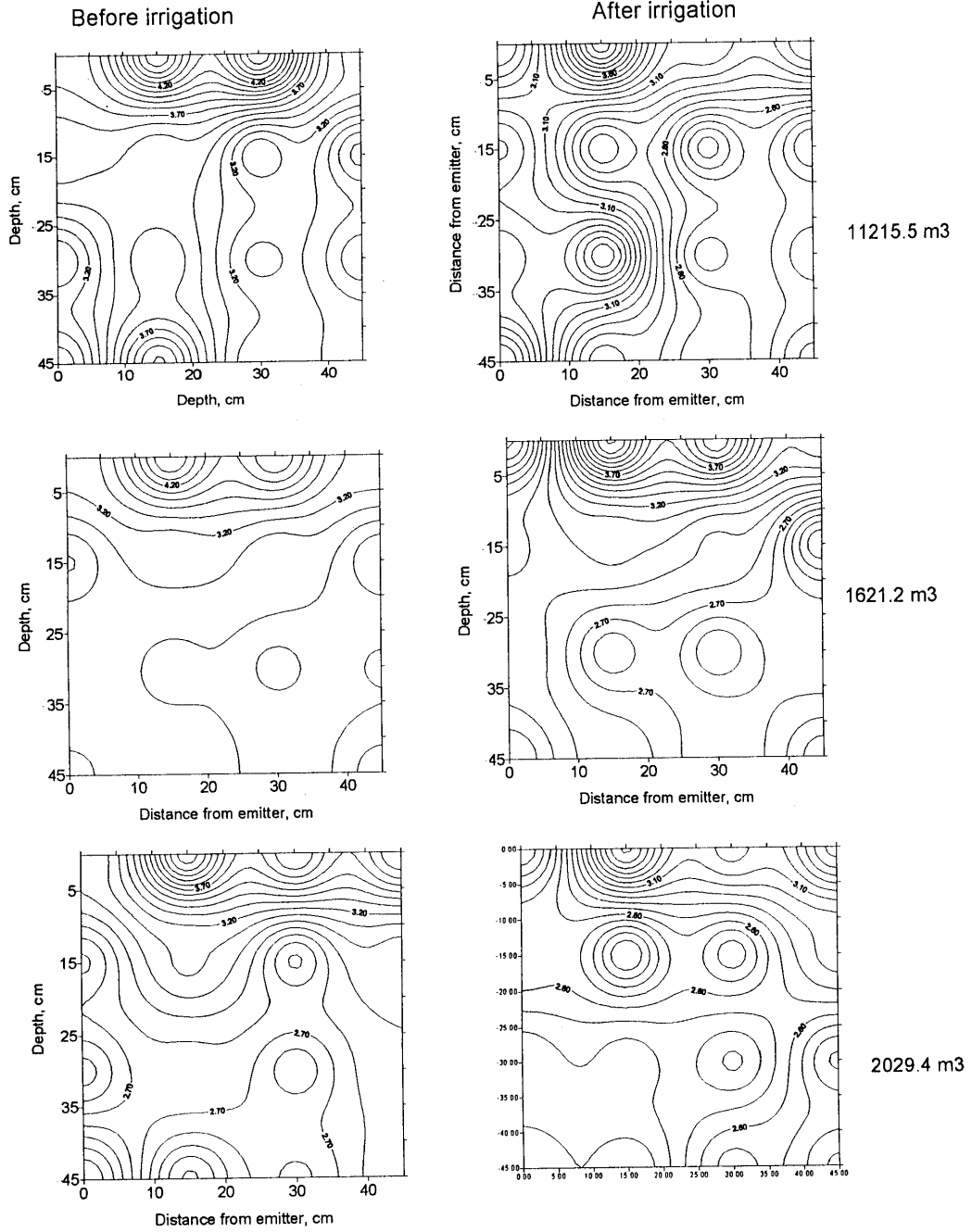


Fig.13-a: Salt content and distribution as affected by applied water volume under drip

irrigation at 2.85 mmhos/cm irrigation water salinity for corn

Along lateral

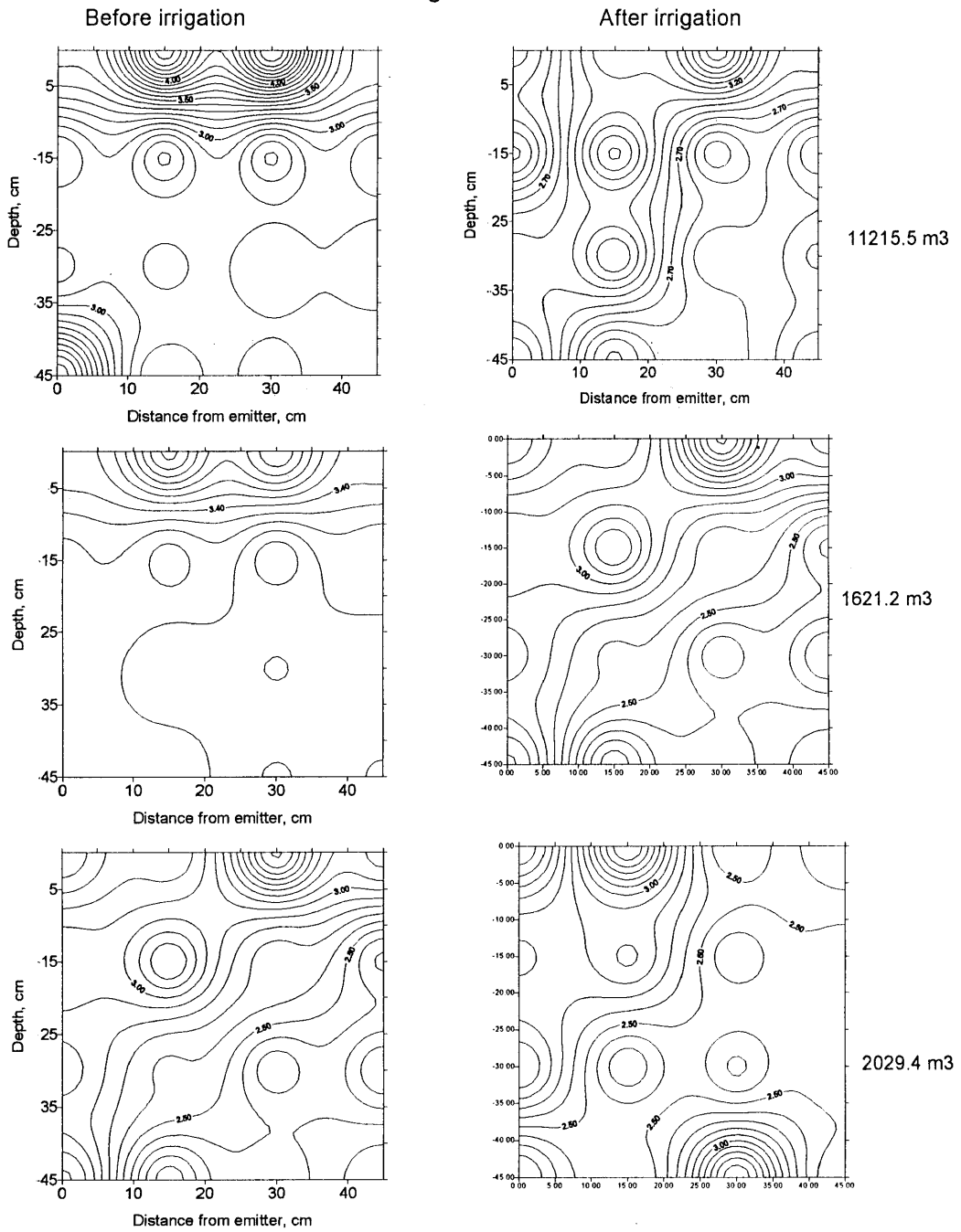


Fig.13-b: Salt content and distribution as affected by applied water volume under drip irrigation at 2.85 mmhos/cm irrigation water salinity for corn

Along lateral

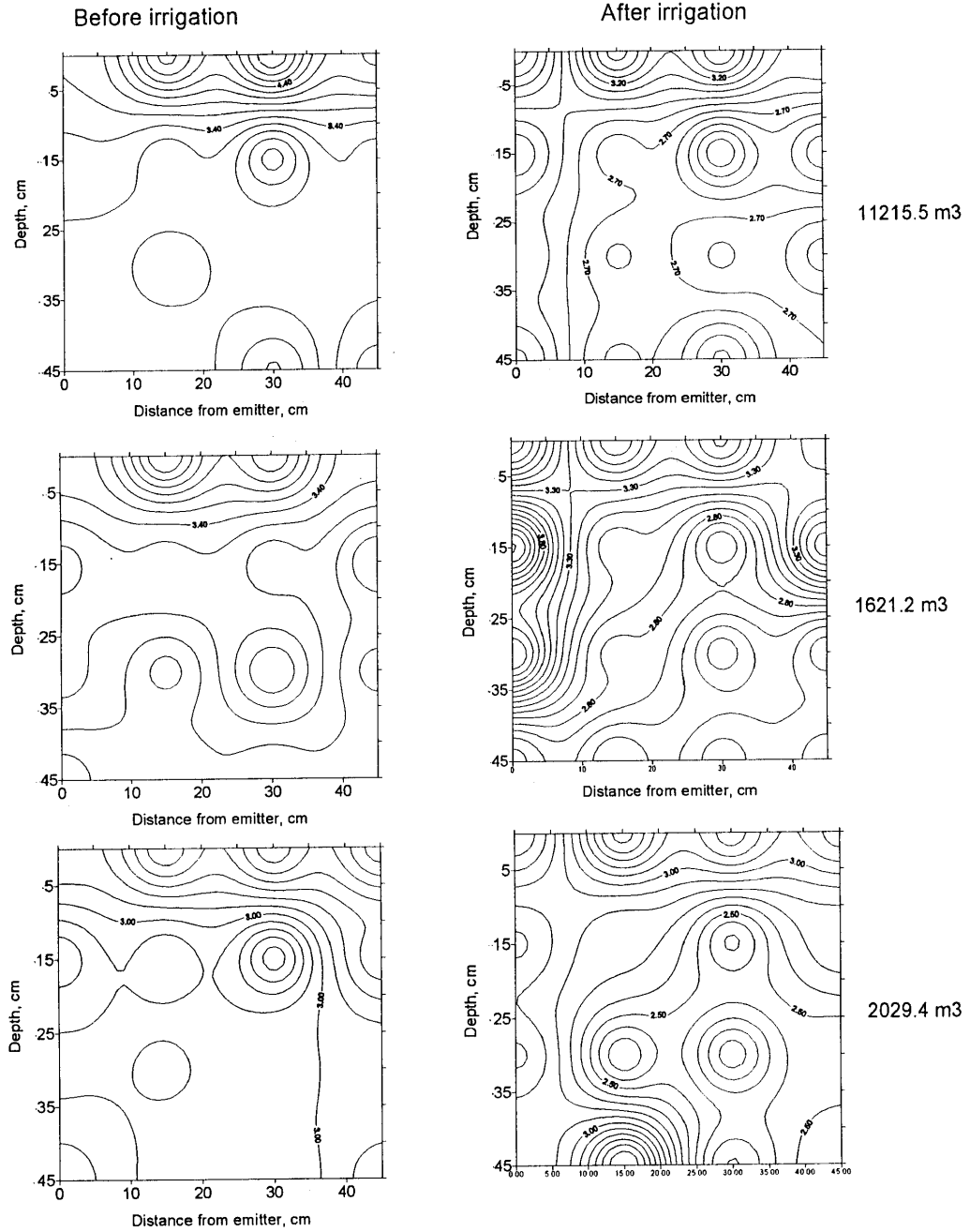


Fig.14-b: Salt content and distribution as affected by applied water volume under drip

irrigation at 3.61 mmhos/cm irrigation water salinity for corn

Across lateral

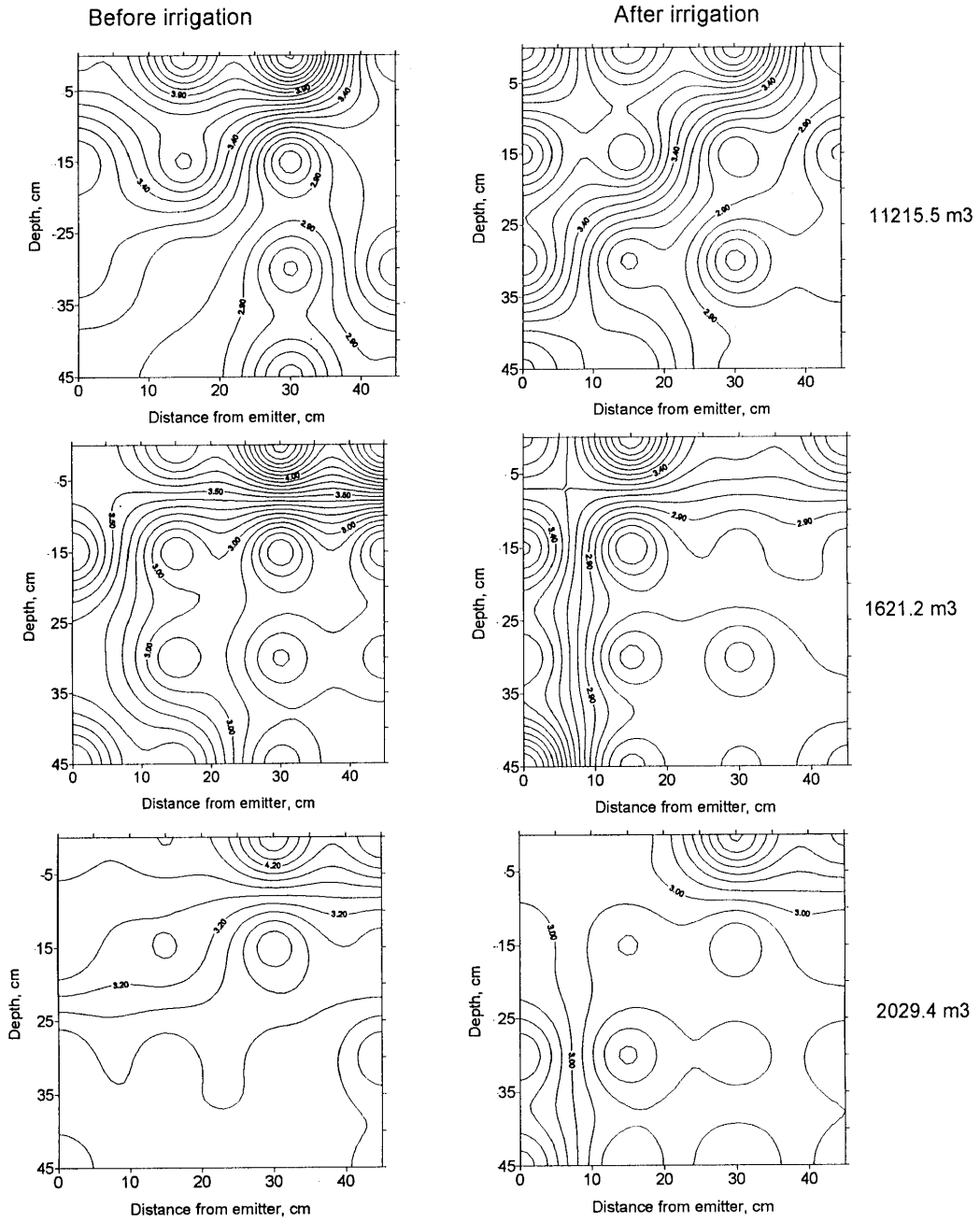


Fig.14-D: Salt content and distribution as affected by applied water volume under drip

irrigation at 3.61 mmhos/cm irrigation water salinity for corn

Across lateral

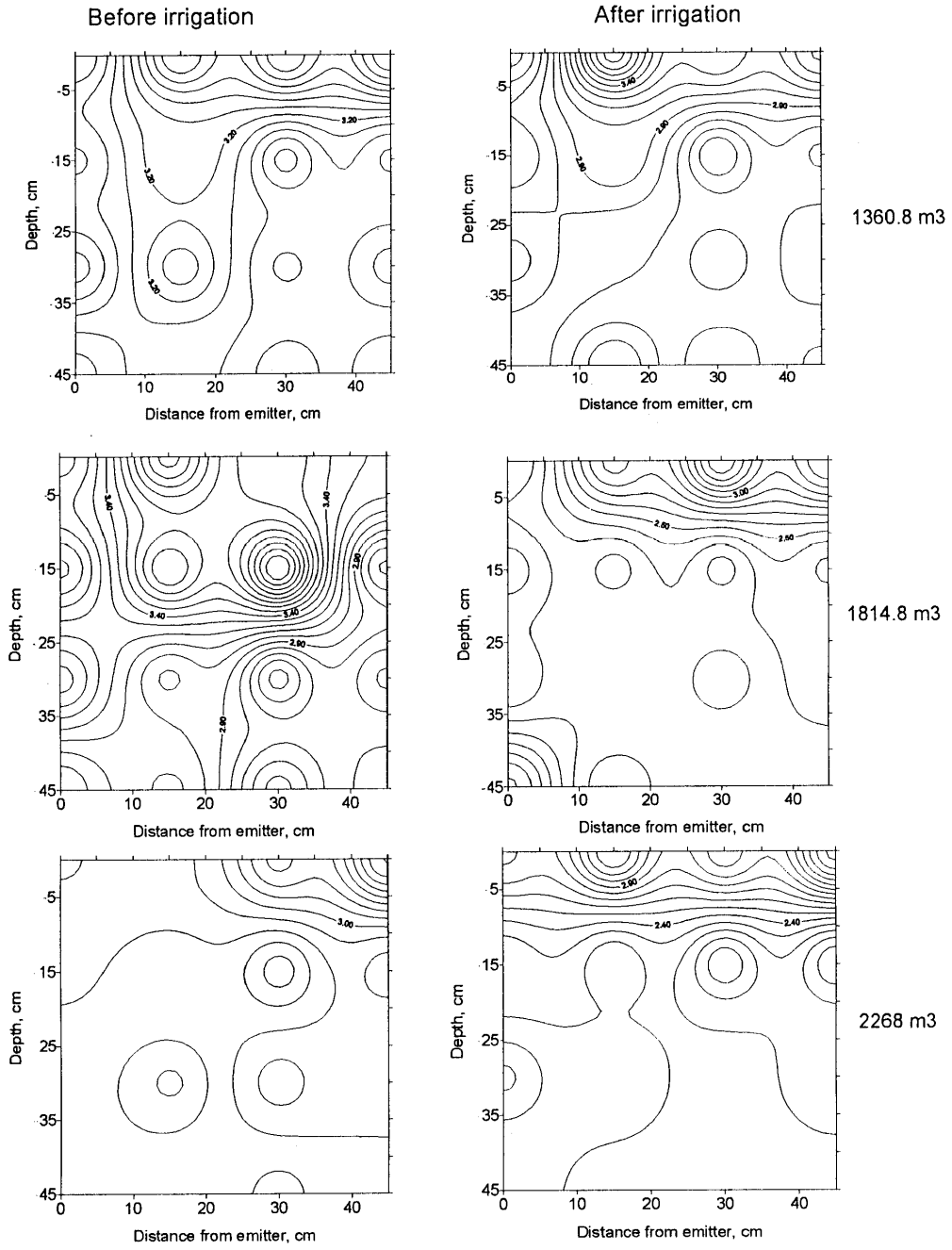


Fig.15-a: Salt content and distribution as affected by applied water volume under drip irrigation at 1.33 mmhos/cm irrigation water salinity for sunflower

Along lateral

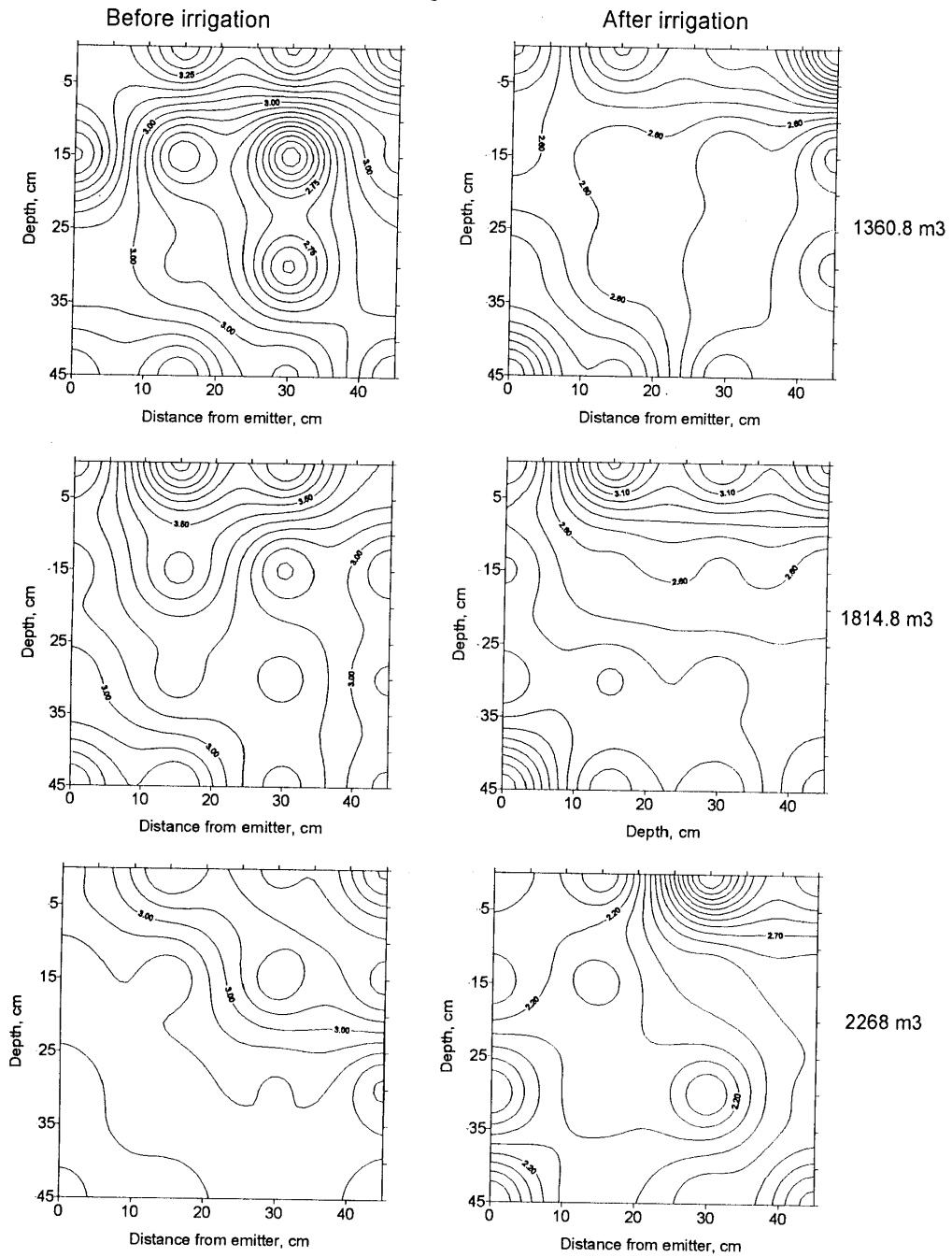


Fig.15-b: Salt content and distribution as affected by applied water volume under drip irrigation at 1.33 mmhos/cm irrigation water salinity for sunflower

Across lateral

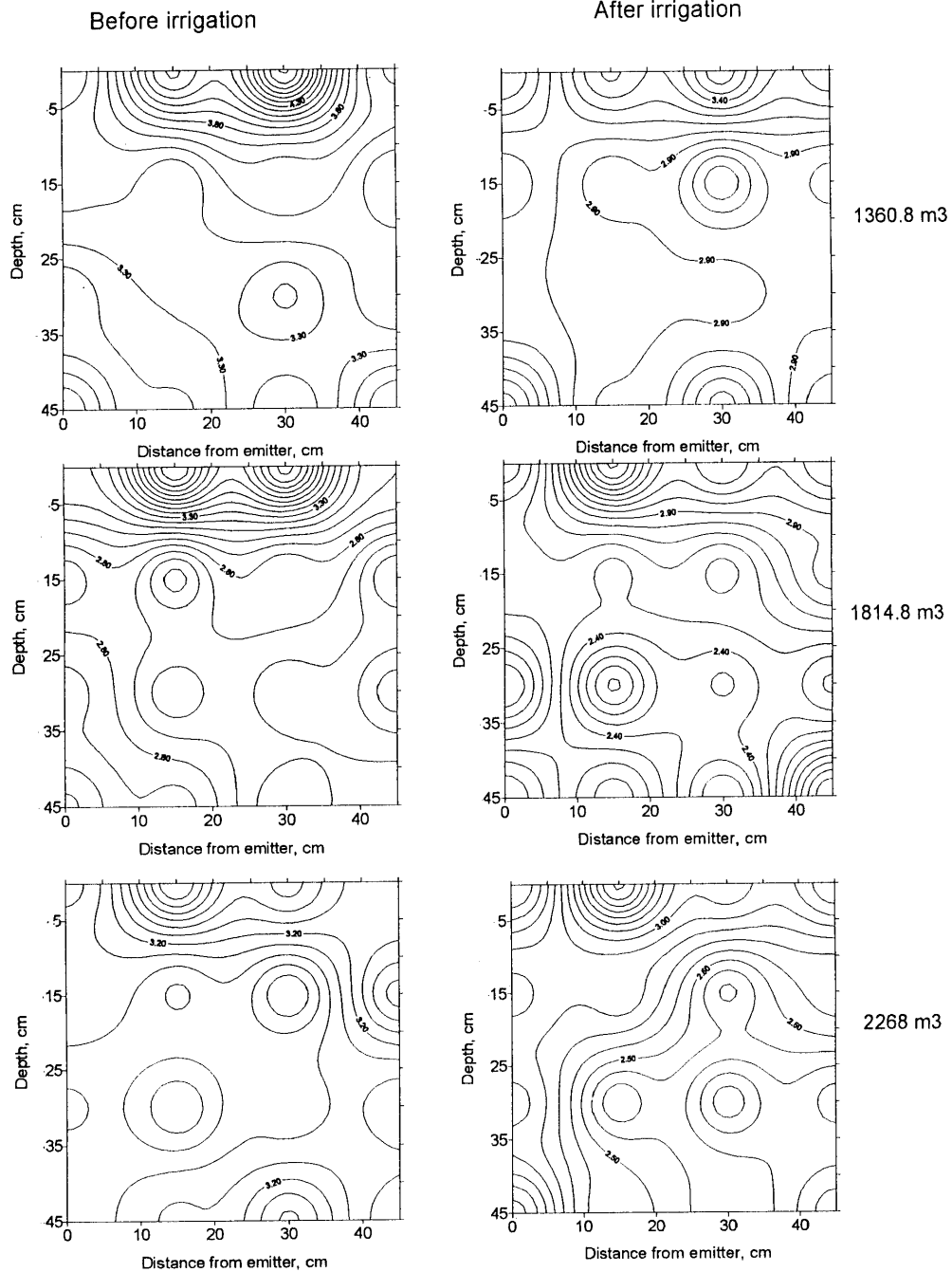


Fig.16-a: Salt content and distribution as affected by applied water volume under drip irrigation at 2.087 mmhos/cm irrigation water salinity for sunflower



Along lateral

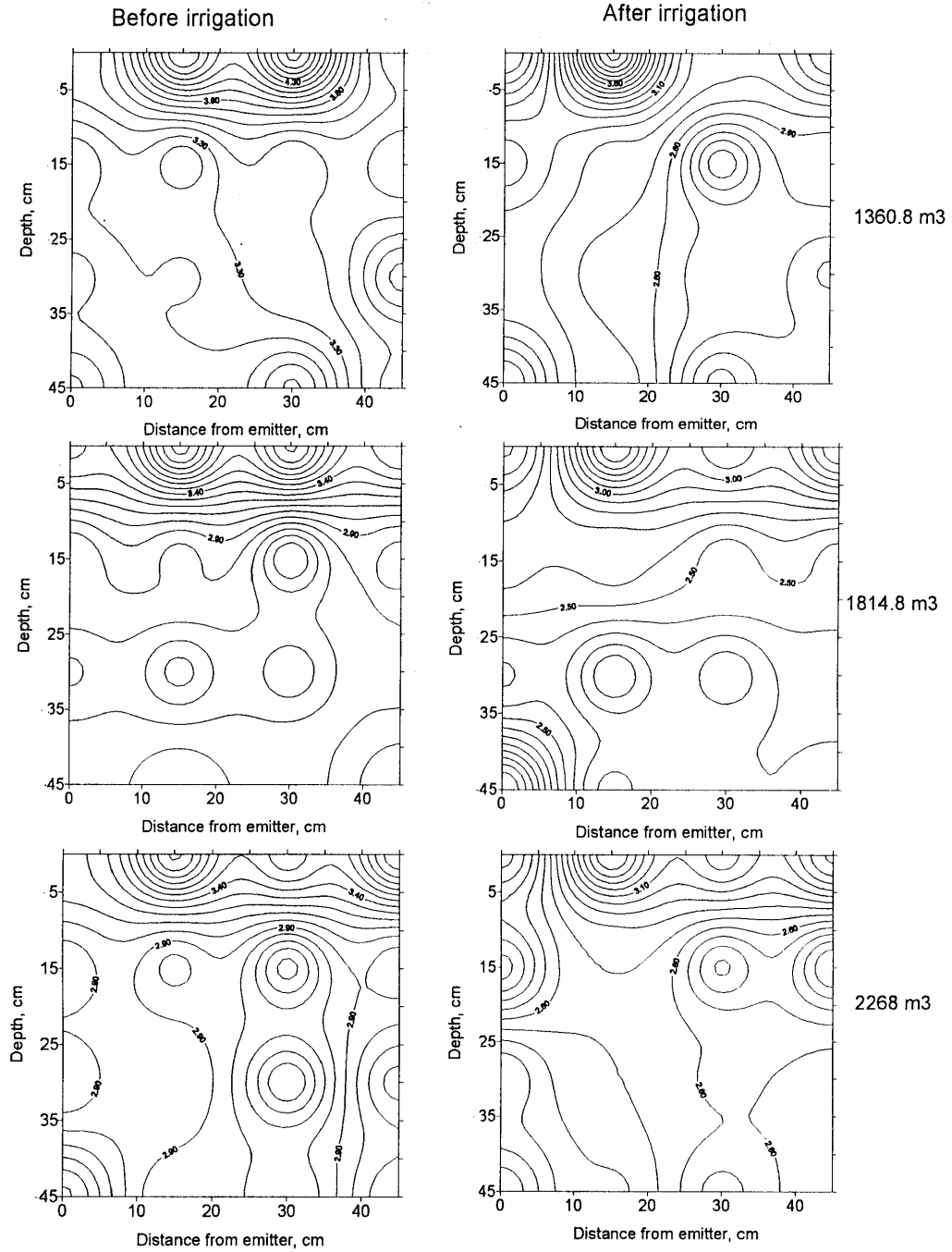


Fig.16-b: Salt content and distribution as affected by applied water volume under drip irrigation at 2.087 mmhos/cm irrigation water salinity for sunflower

Across lateral

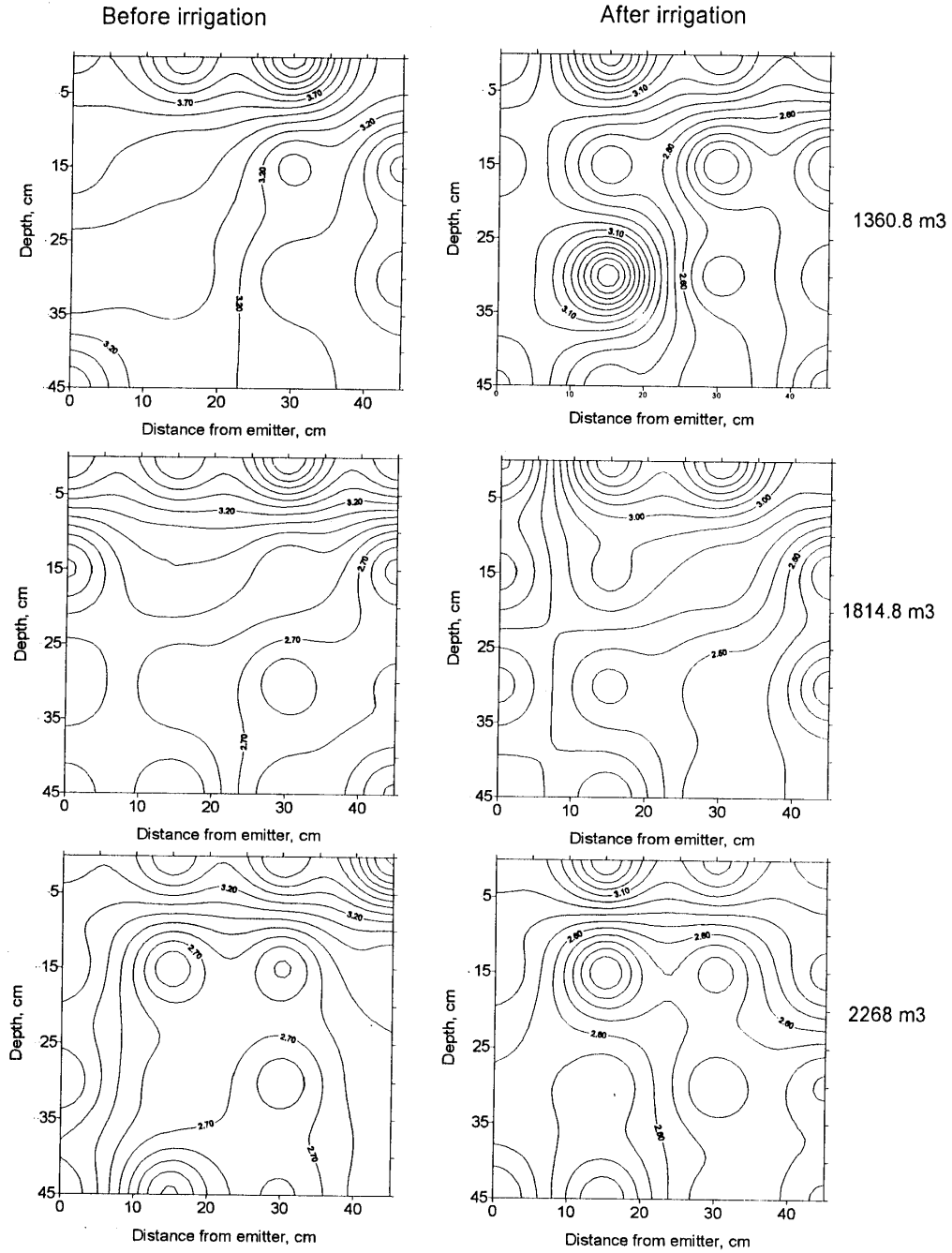


Fig.17-a: Soil content and distribution as affected by applied water volume under drip irrigation at 2.85 mmhos/cm irrigation water salinity for sunflower

Along lateral

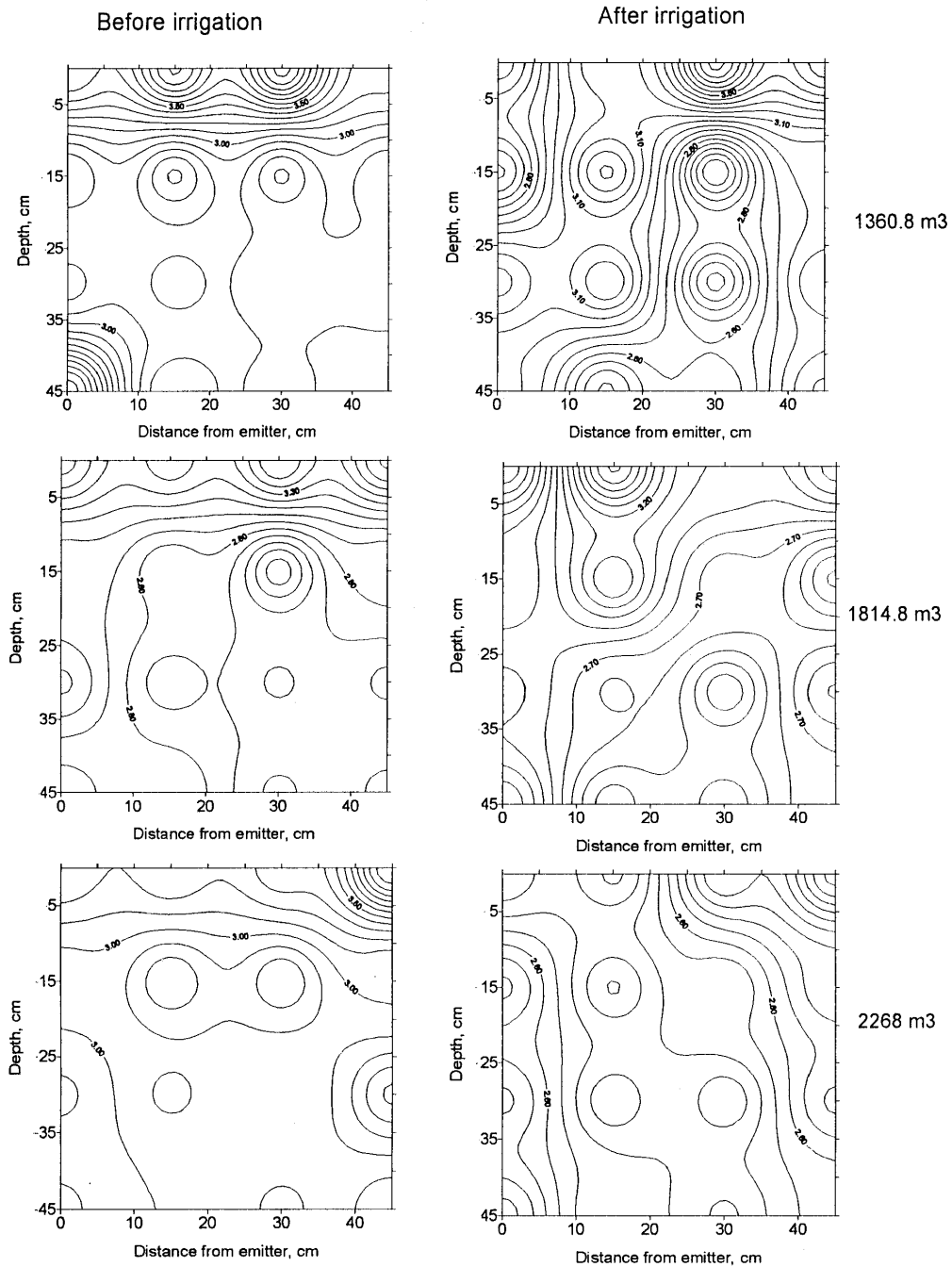


Fig.17-b: Salt content and distribution as affected by applied water volume under drip irrigation at 2.85 mmhos/cm irrigation water salinity for sunflower

Along lateral

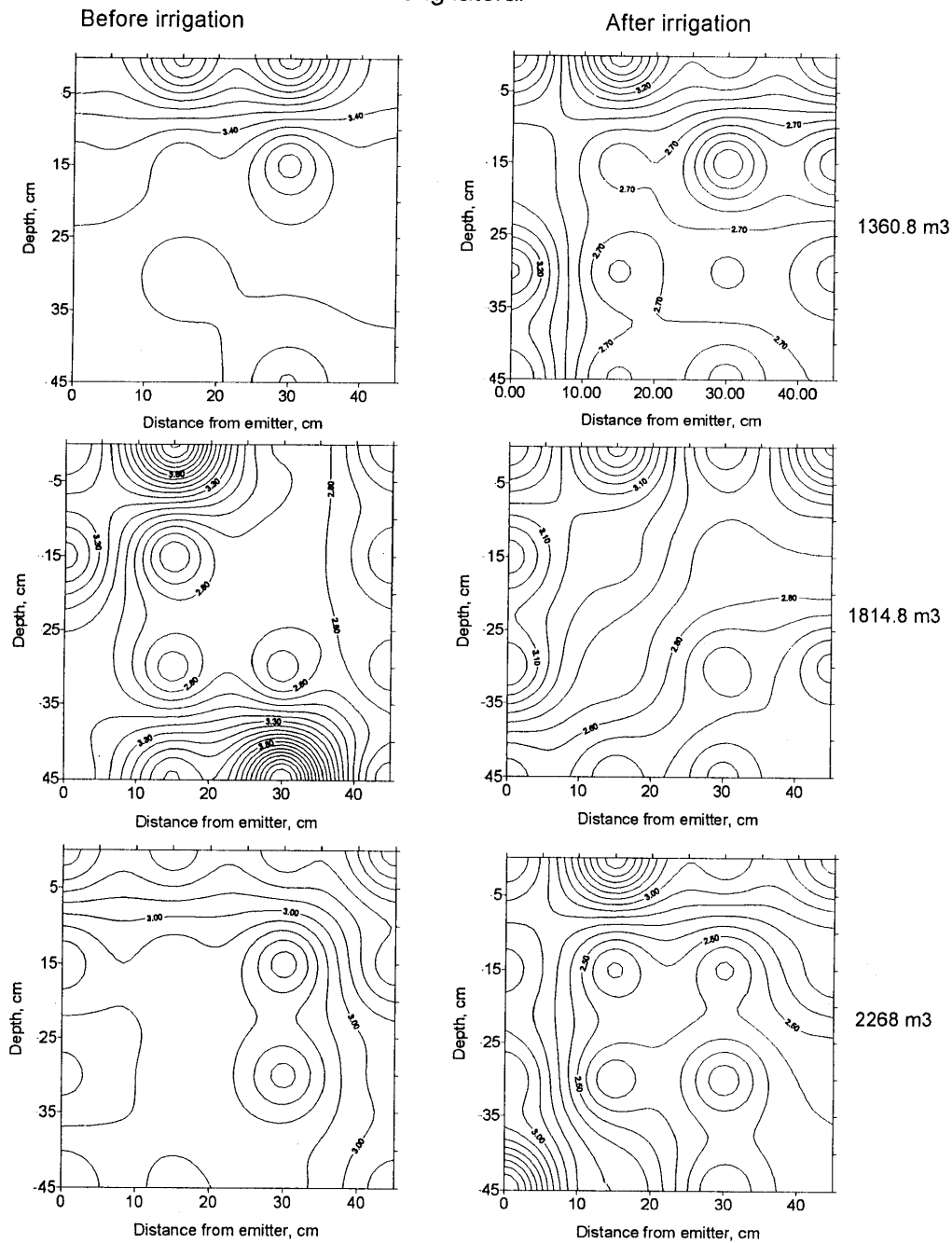


Fig.18-b: Salt content and distribution as affected by applied water volume under drip irrigation at 3.61 mmhos/cm irrigation water salinity for sunflower

Across lateral

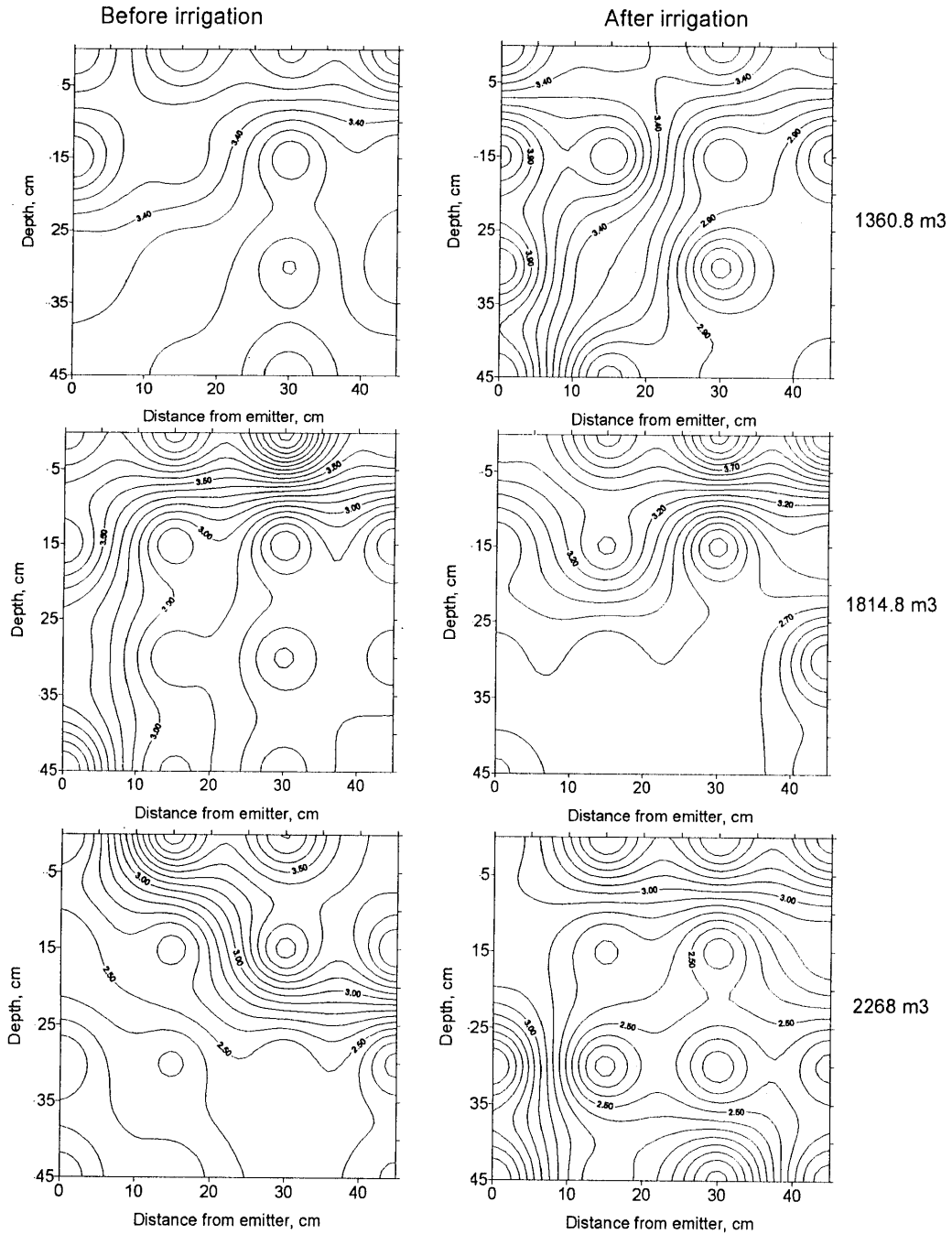


Fig.18-b: Salt content and distribution as affected by applied water volume under drip irrigation at 1.33 mmhos/cm irrigation water salinity for sunflower

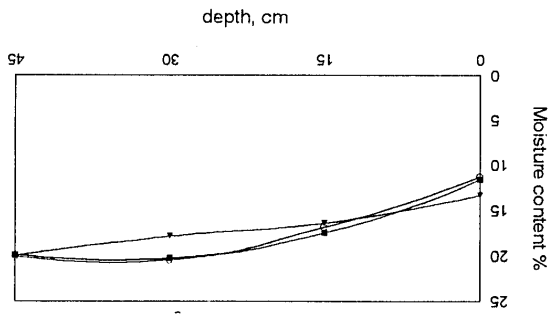


Fig. 21: Effect of applied water volume on soil moisture content at 2.85 mmhos/cm, irrigation water salinity under flood irrigation for corn.

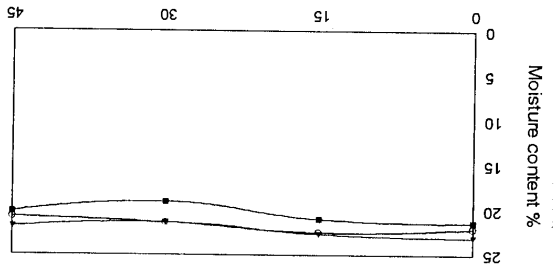
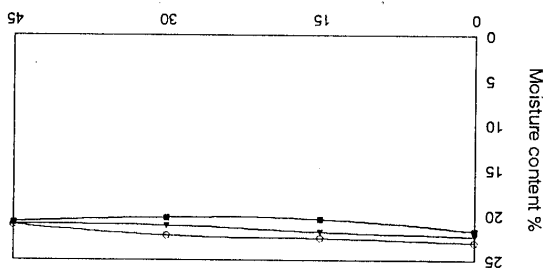
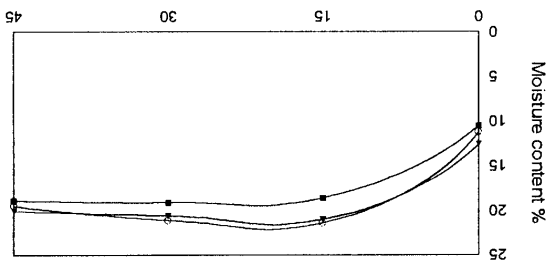


Fig. 22: Effect of applied water volume on soil moisture content at 3.61 mmhos/cm, irrigation water salinity under flood irrigation for corn.



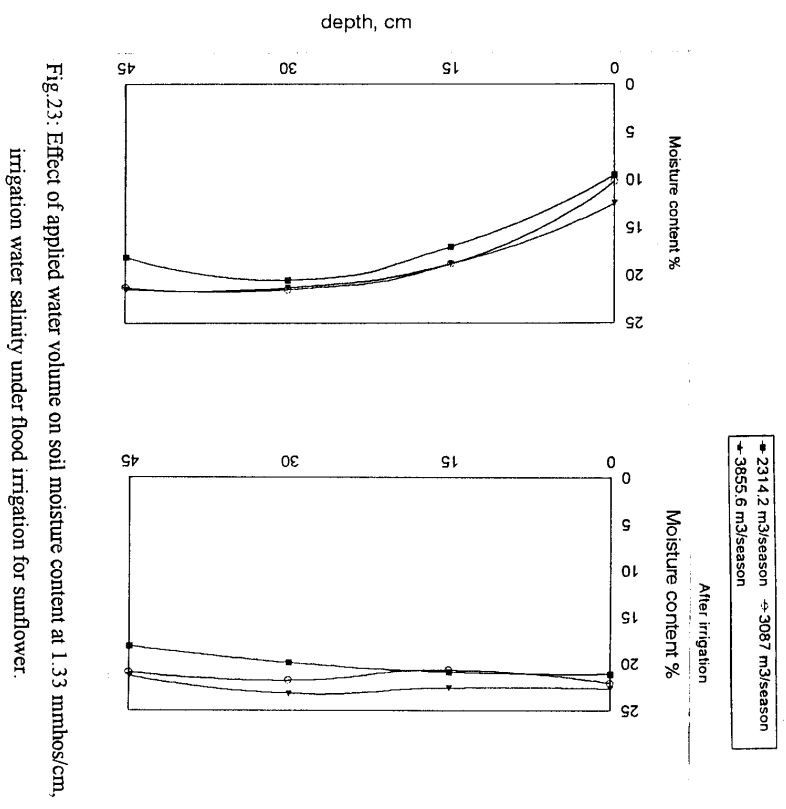


Fig.23: Effect of applied water volume on soil moisture content at 1.33 mmhos/cm, irrigation water salinity under flood irrigation for sunflower.

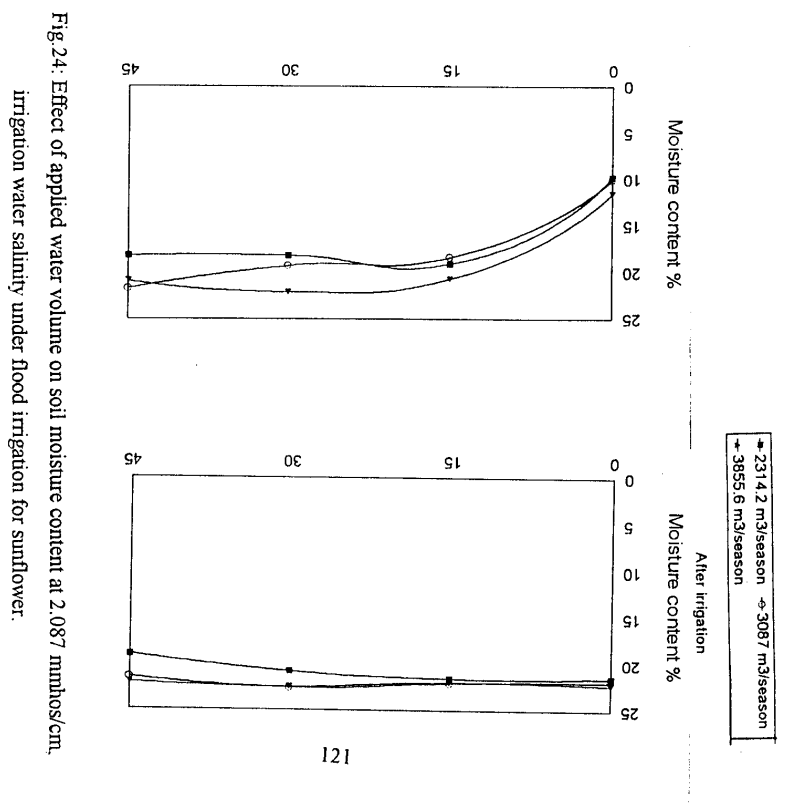


Fig.24: Effect of applied water volume on soil moisture content at 2.087 mmhos/cm, irrigation water salinity under flood irrigation for sunflower.

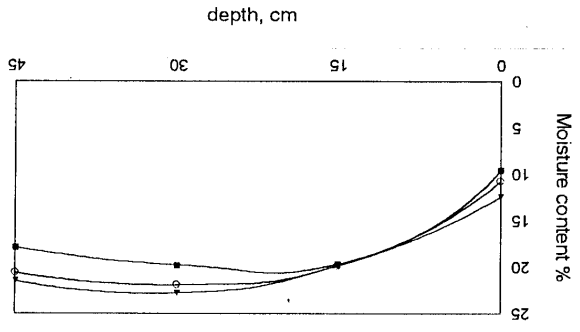


Fig. 25: Effect of applied water volume on soil moisture content at 2.85 mmhos/cm, irrigation water salinity under flood irrigation for sunflower.

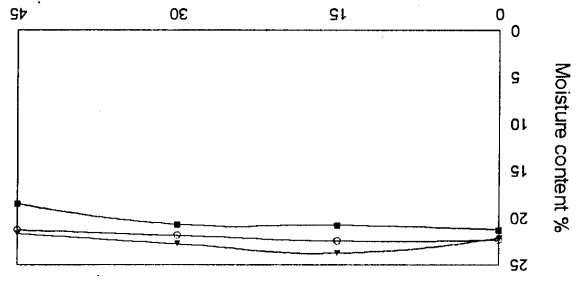
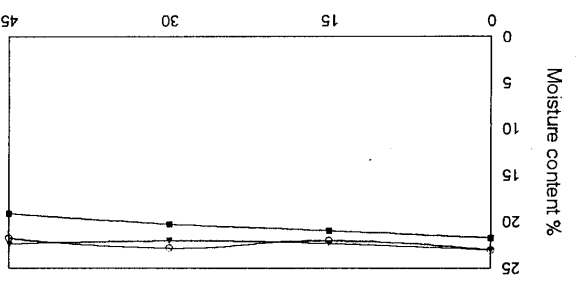
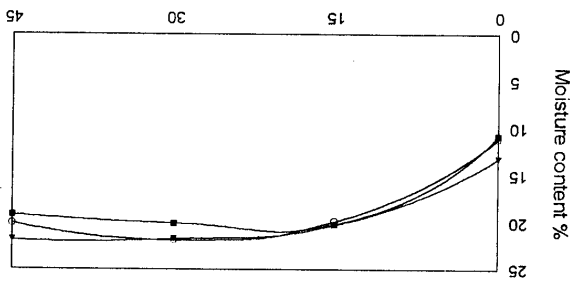


Fig. 26: Effect of applied water volume on soil moisture content at 3.61 mmhos/cm, irrigation water salinity under flood irrigation for sunflower.





Along lateral

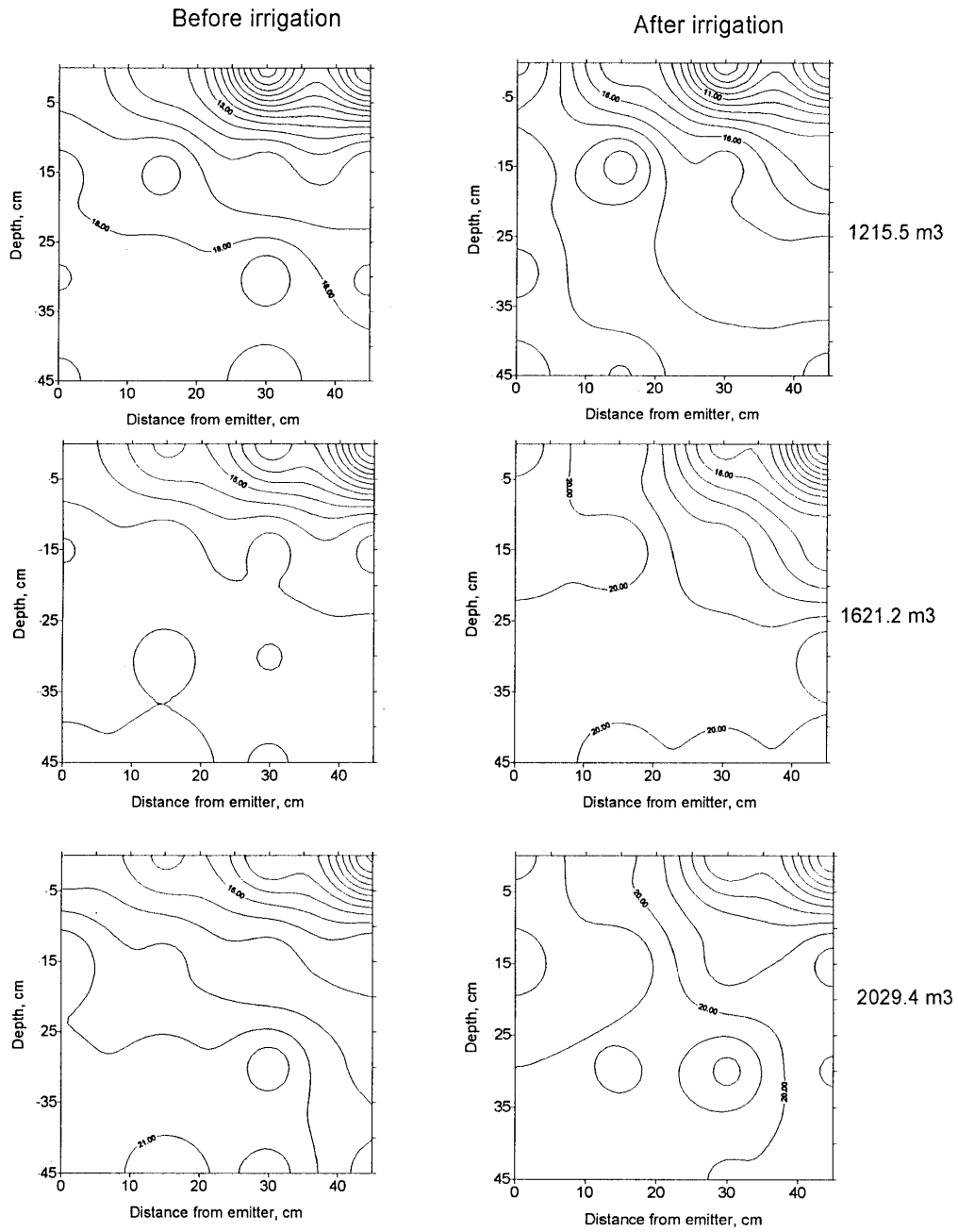


Fig.27-b: Soil moisture content and distribution as affected by applied water volume under drip irrigation at 1.33 mmhos/cm irrigation water salinity for corn

Across lateral

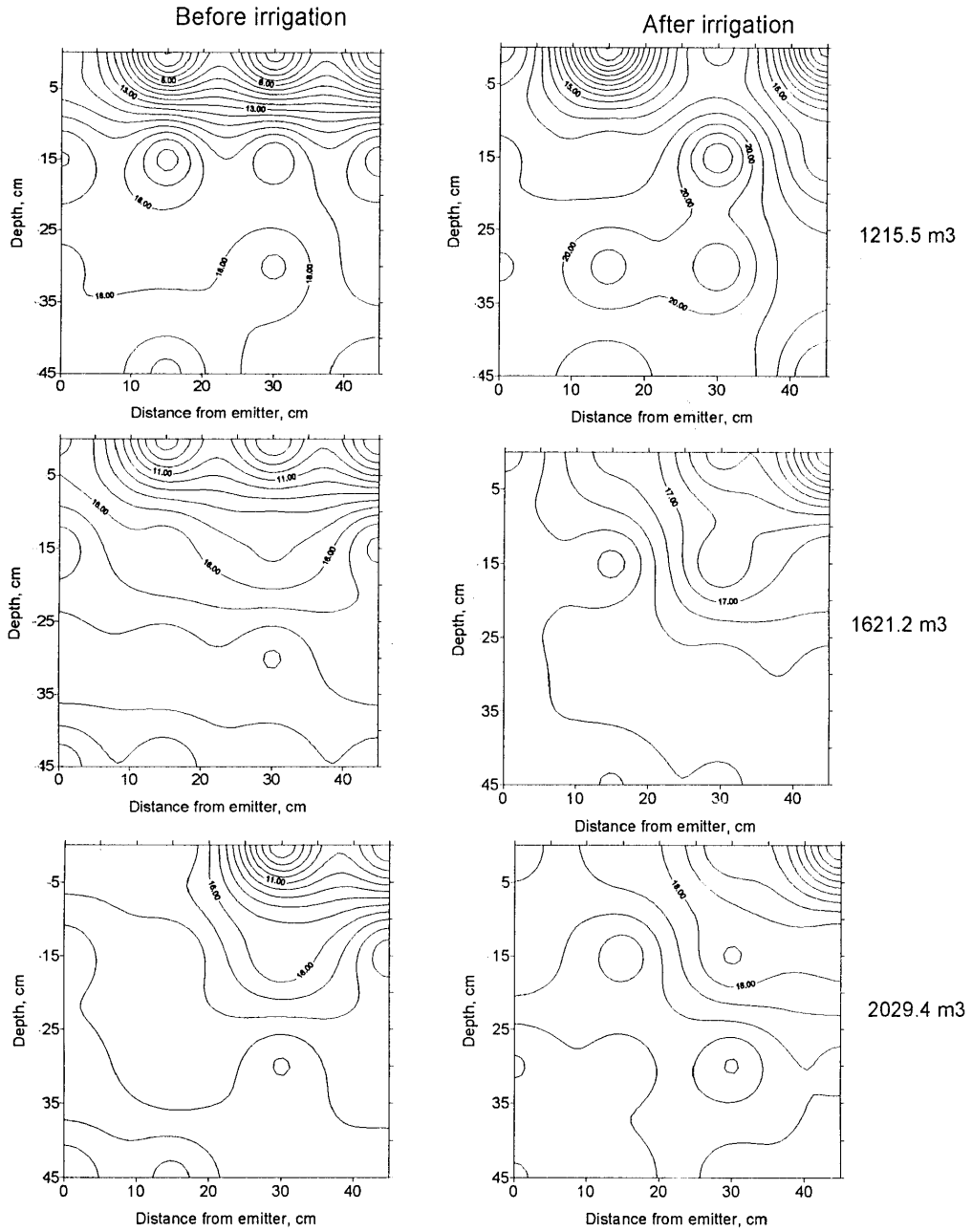


Fig.28-a: Soil moisture content and distribution as affected by applied water volume under drip irrigation at 2.087 mmhos/cm irrigation water salinity for corn

Along lateral

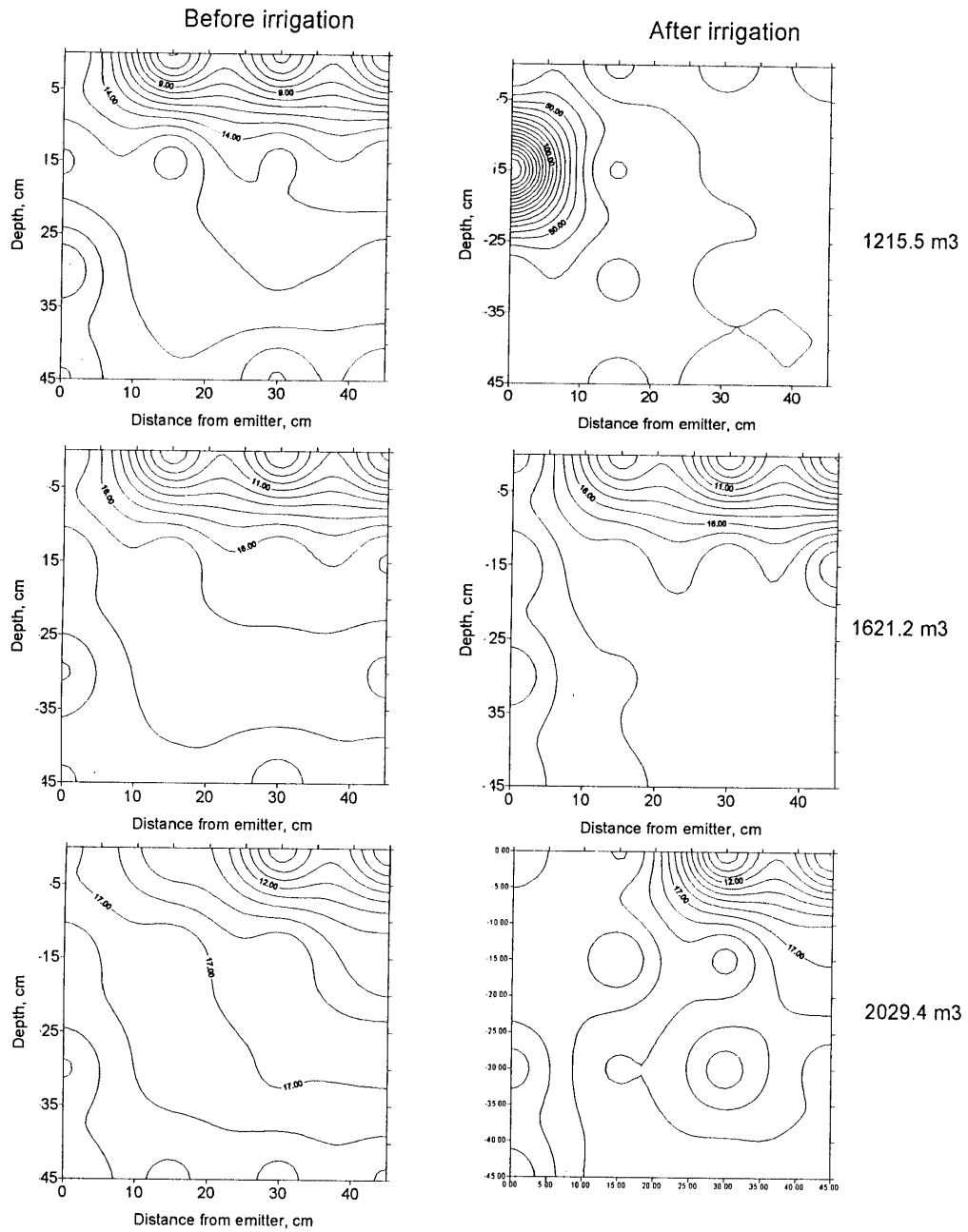


Fig.28-b: Soil moisture content and distribution as affected by applied water volume under drip irrigation at 2.087 mmhos/cm irrigation water salinity for corn

Across lateral

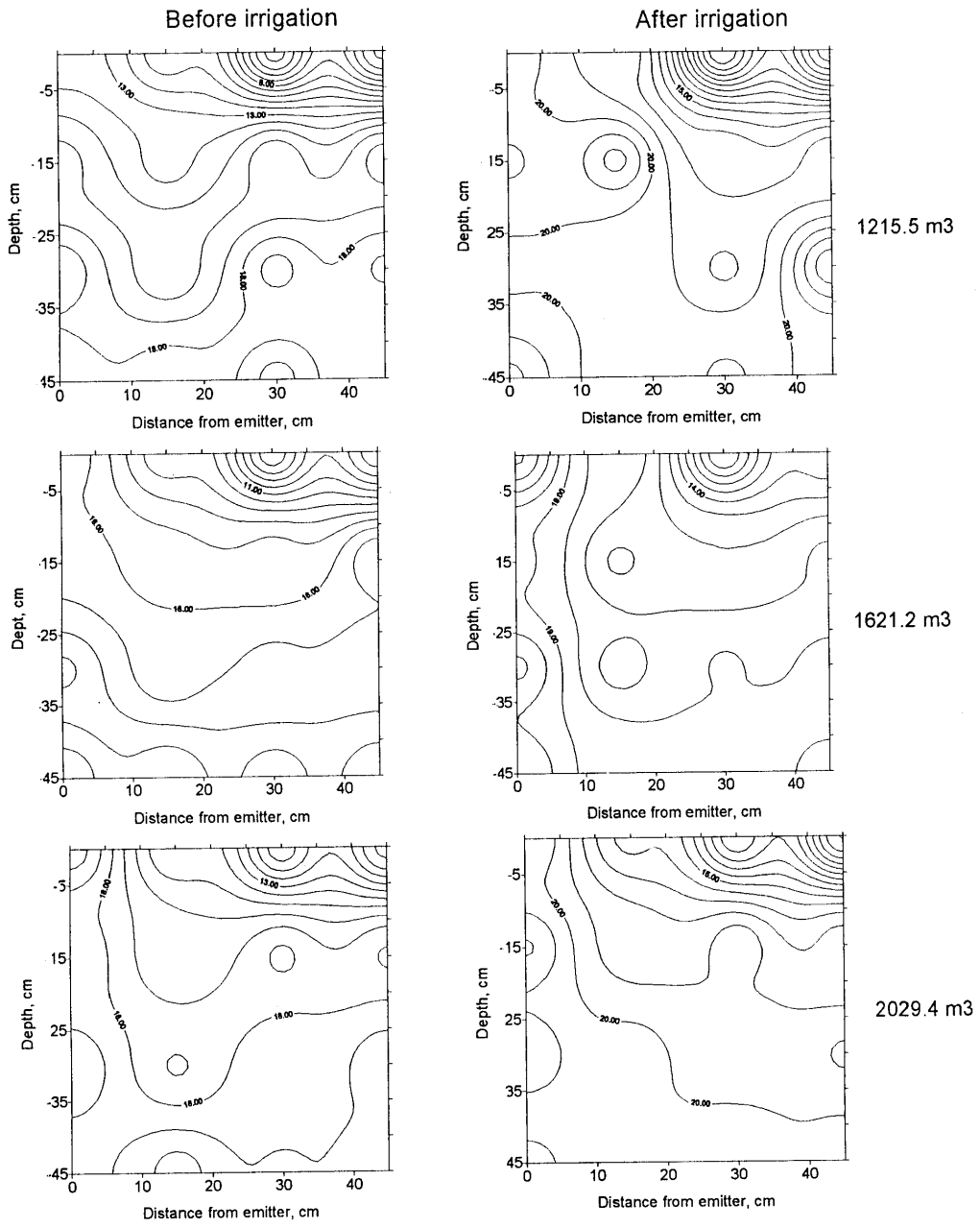


Fig.29-a: Soil moisture content and distribution as affected by applied water volume under drip irrigation at 2.85 mmhos/cm irrigation water salinity for corn

Along lateral

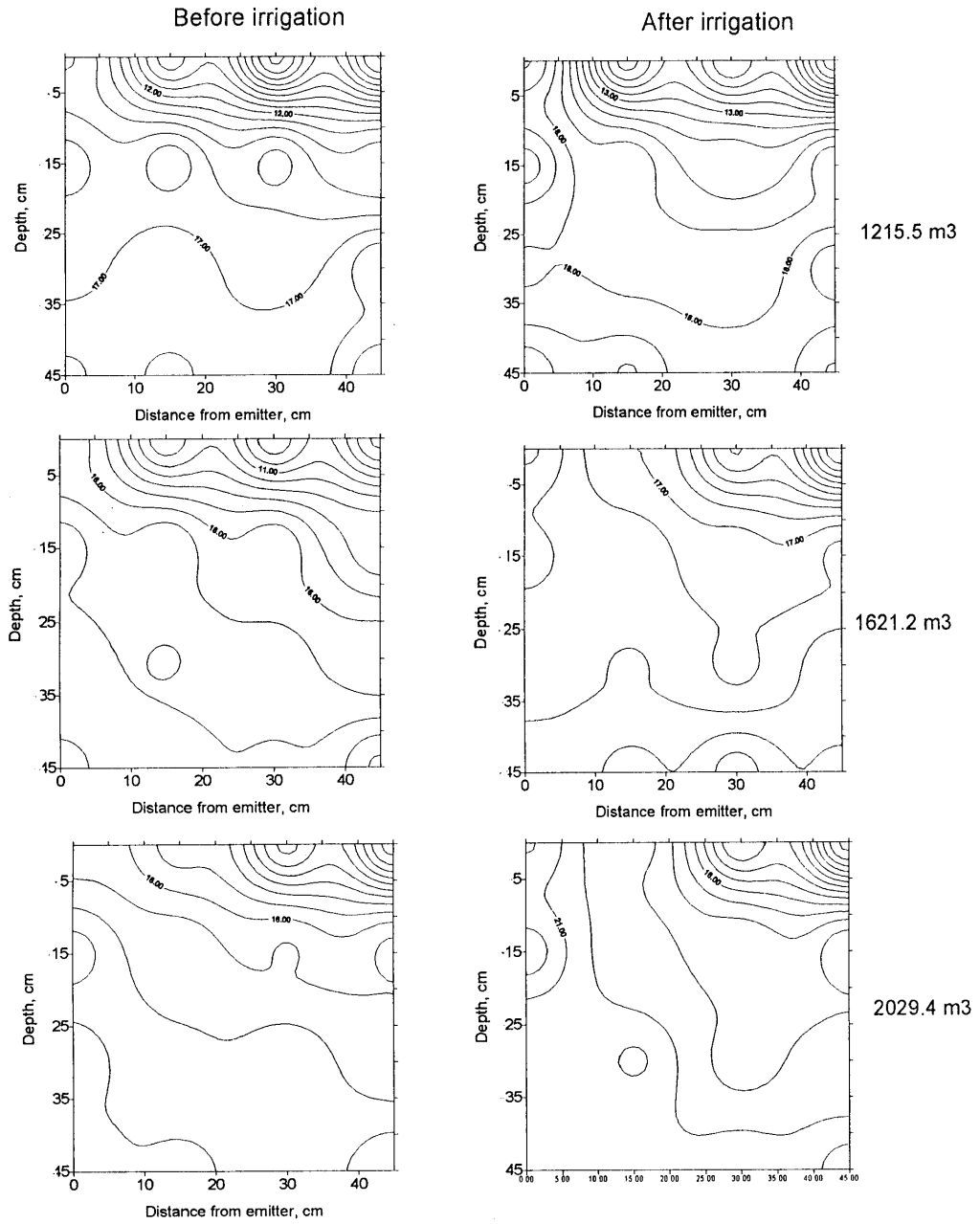


Fig.29-b: Soil moisture content and distribution as affected by applied water volume under drip irrigation at 2.85 mmhos/cm irrigation water salinity for corn

Across lateral

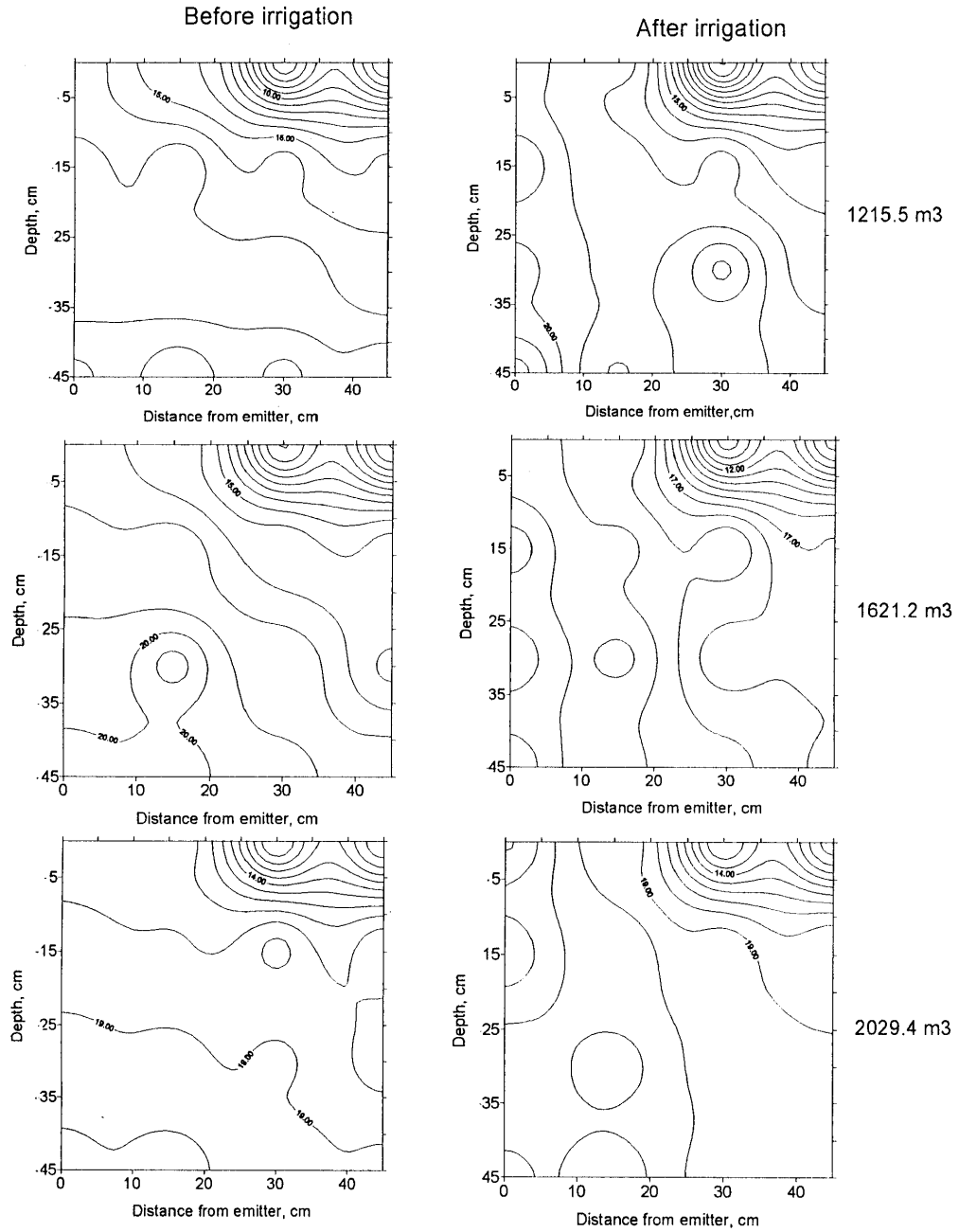


Fig.30-a: Soil moisture content and distribution as affected by applied water volume under drip irrigation at 3.61 mmhos/cm irrigation water salinity for corn

Along lateral

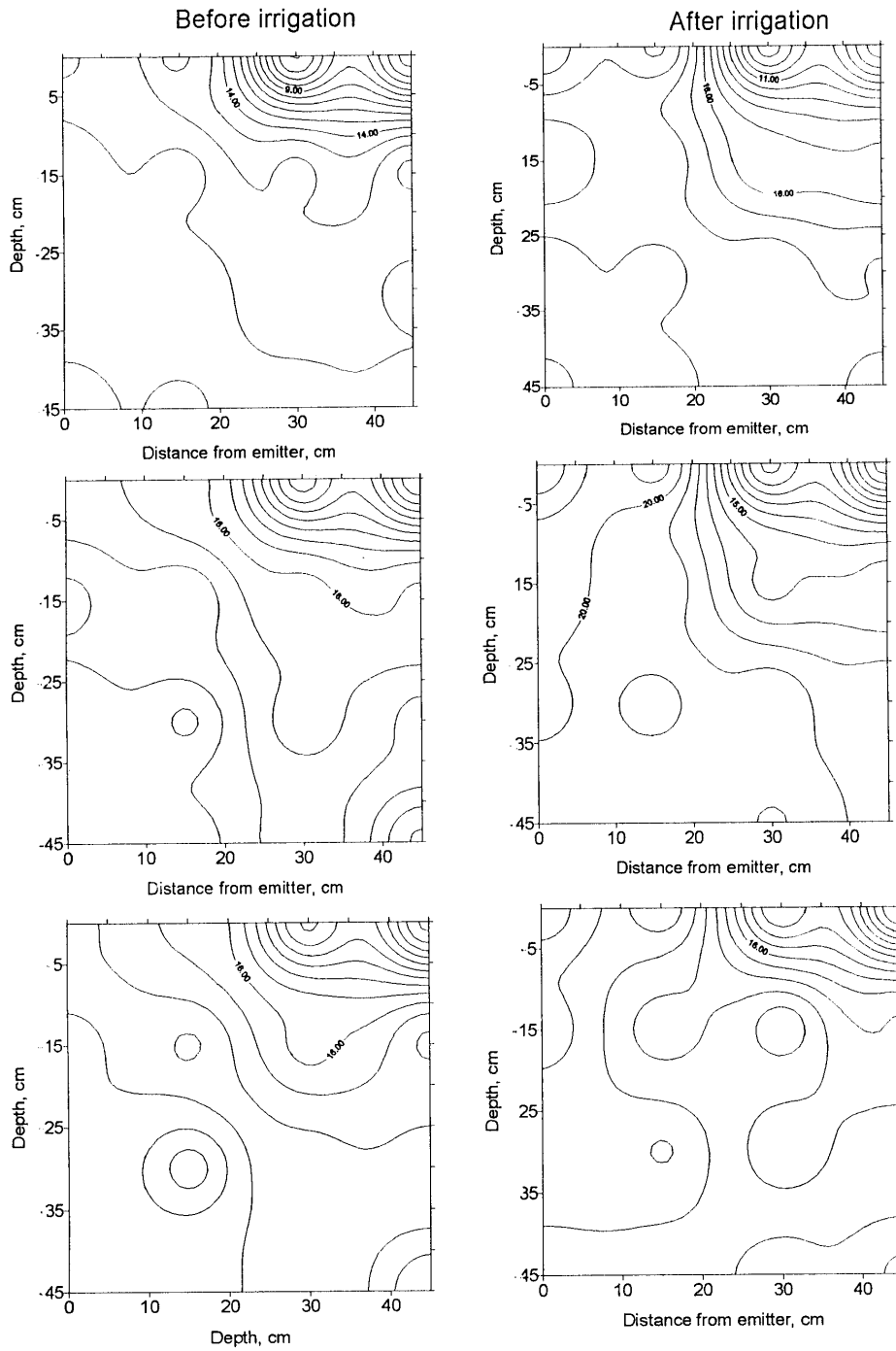


Fig.30-b: Soil moisture content and distribution as affected by applied water volume under drip irrigation at 3.61 mmhos/cm irrigation water salinity for corn

Across lateral

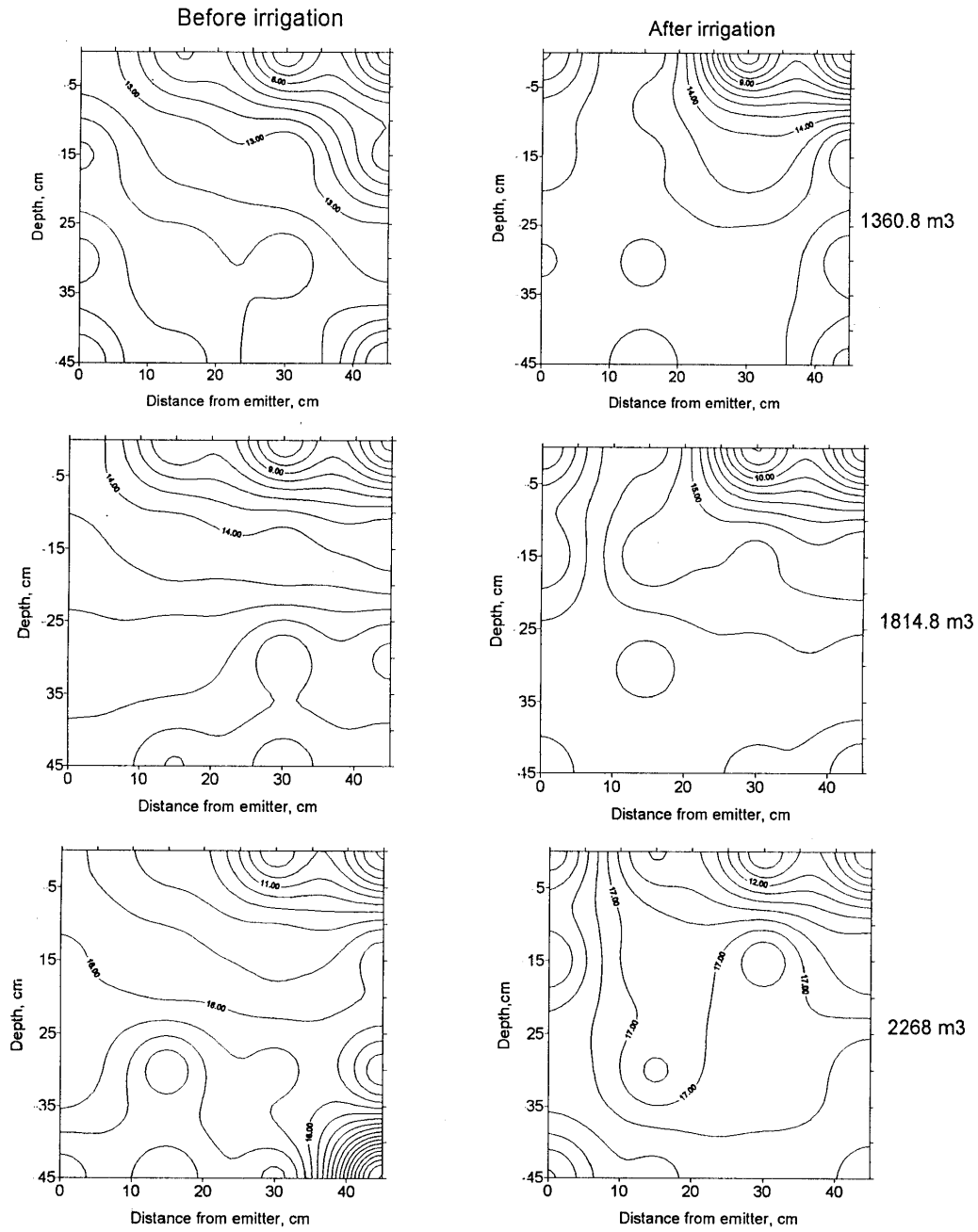


Fig.31-a: Soil moisture content and distribution as affected by applied water vplume under drip irrigation at 1.33 mmhos/cm irrigation water salinity for sunflower



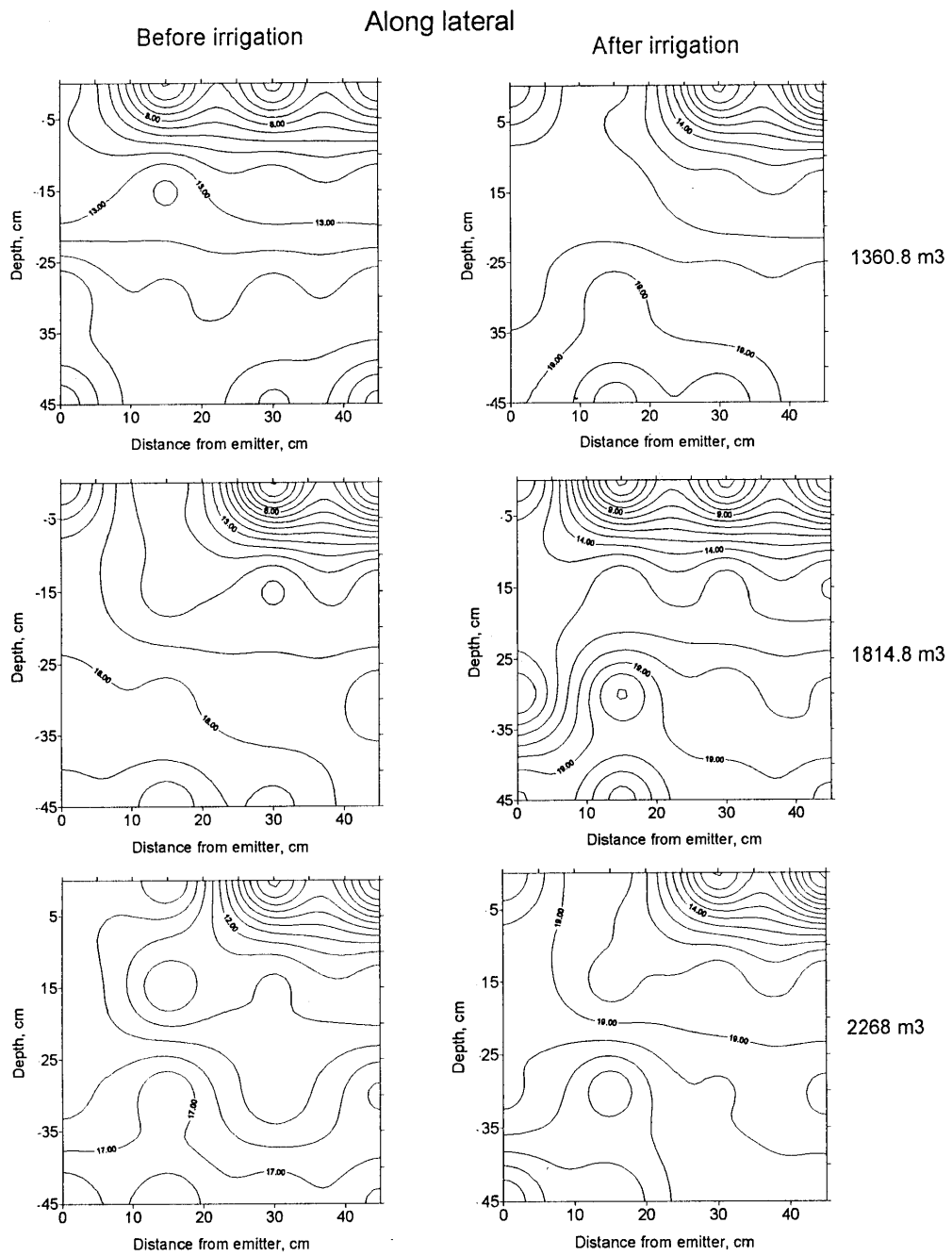


Fig.31-b : Soil moisture content and distribution as affected by applied water volume under drip irrigation at 1.33 mmhos/cm irrigation water salinity for sunflower

Across lateral

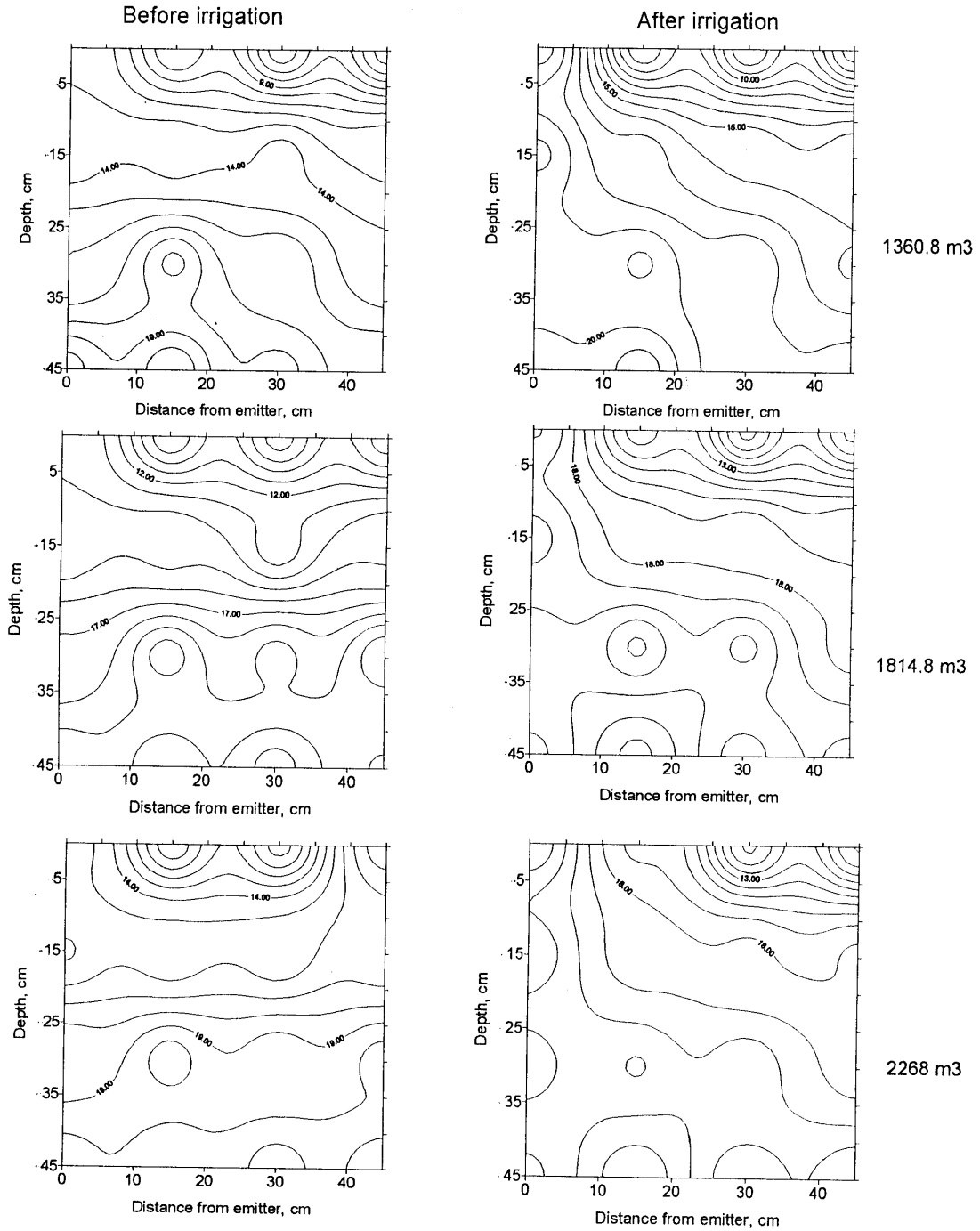


Fig.32-a: Soil moisture content and distribution as affected by applied water volume under drip irrigation at 2.087 mmhos/cm irrigation water salinity for sunflower

Along lateral

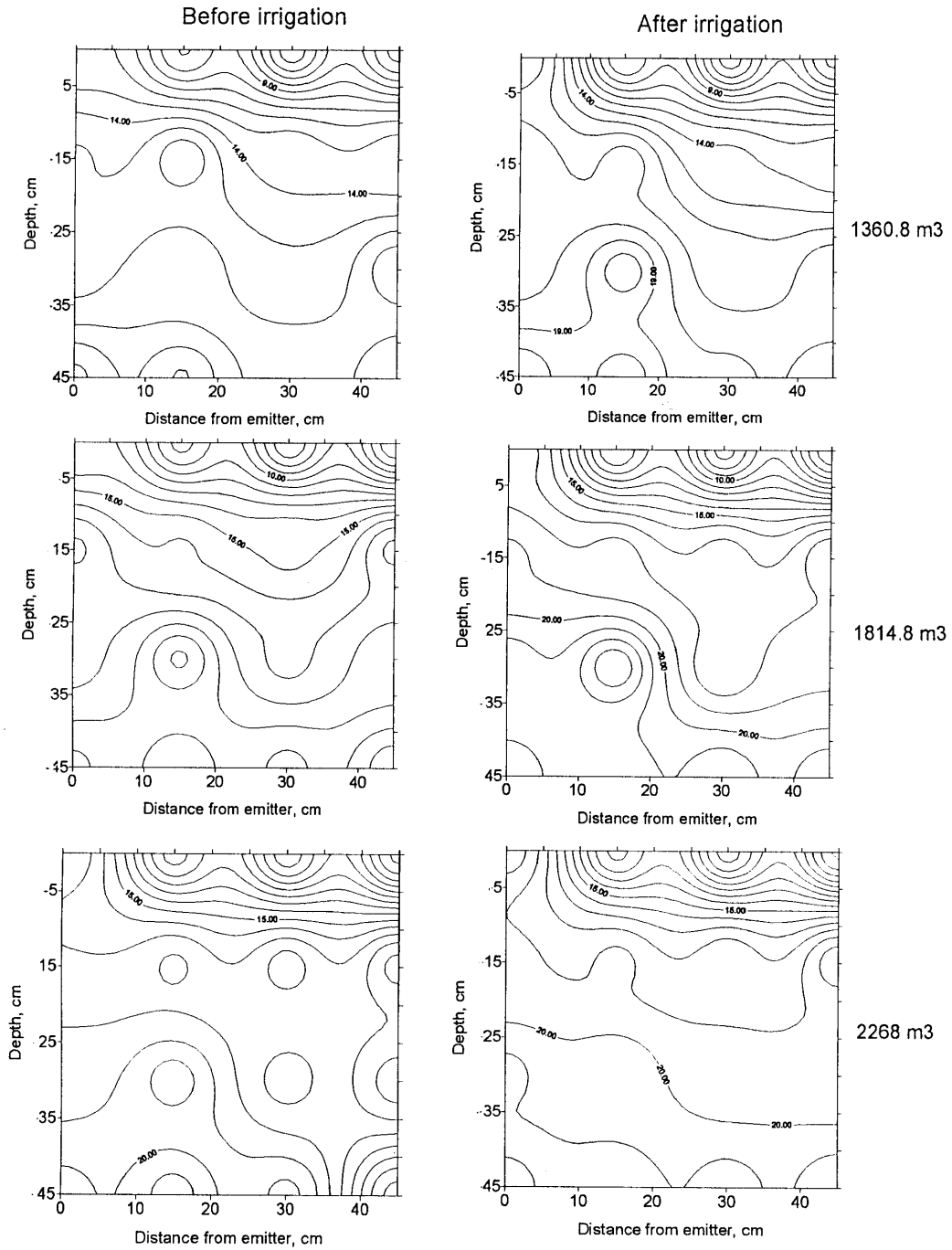


Fig.32-b: Soil moisture content and distribution as affected by applied water volume under drip irrigation system at 2.087 mmhos/cm irrigation water salinity for sunflower

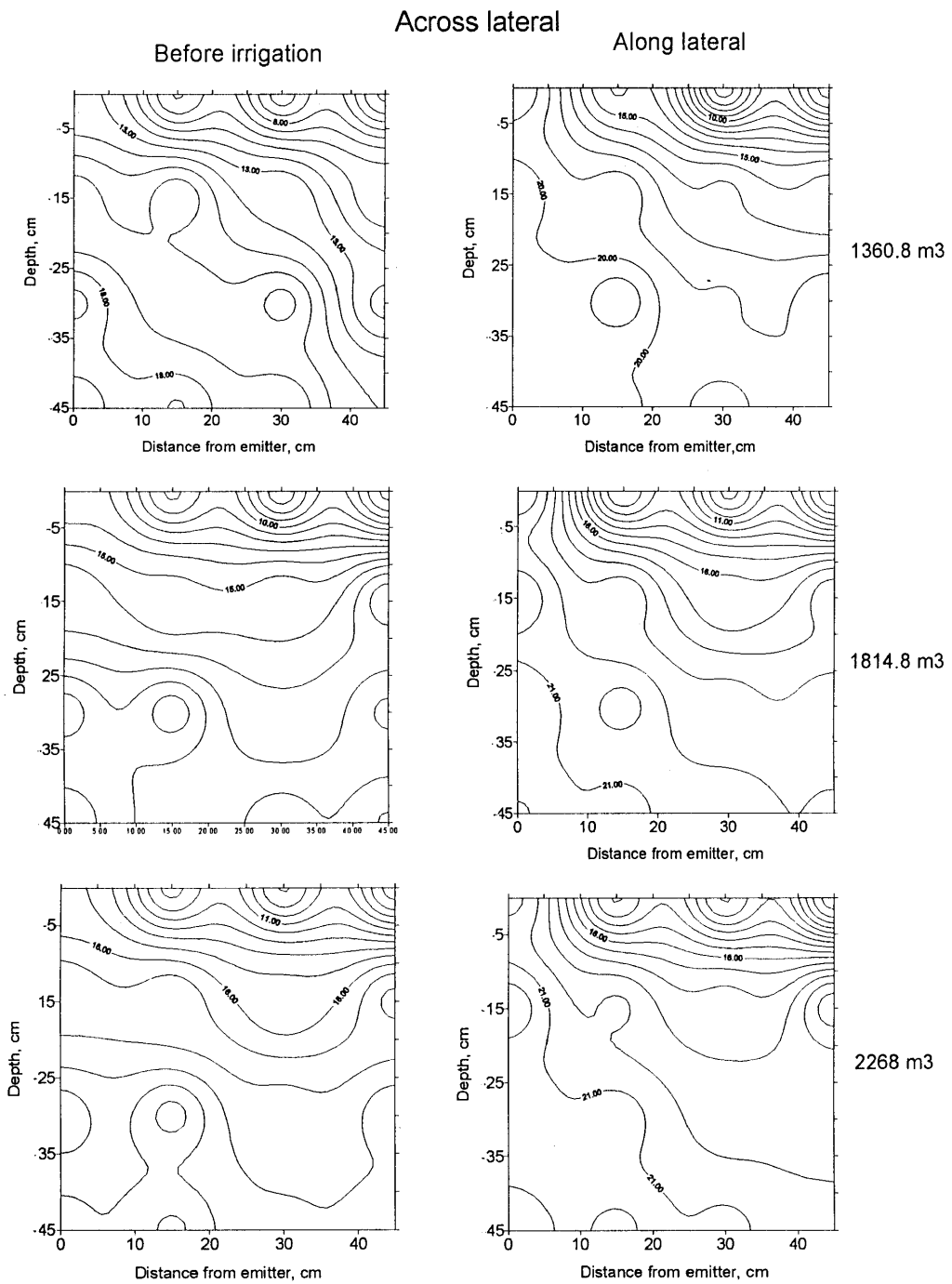


Fig.33-a : Soil moisture content and distribution as affected by applied water volume under drip irrigation system at 2.85 mmhos/cm irrigation water salinity for sunflower

Along lateral

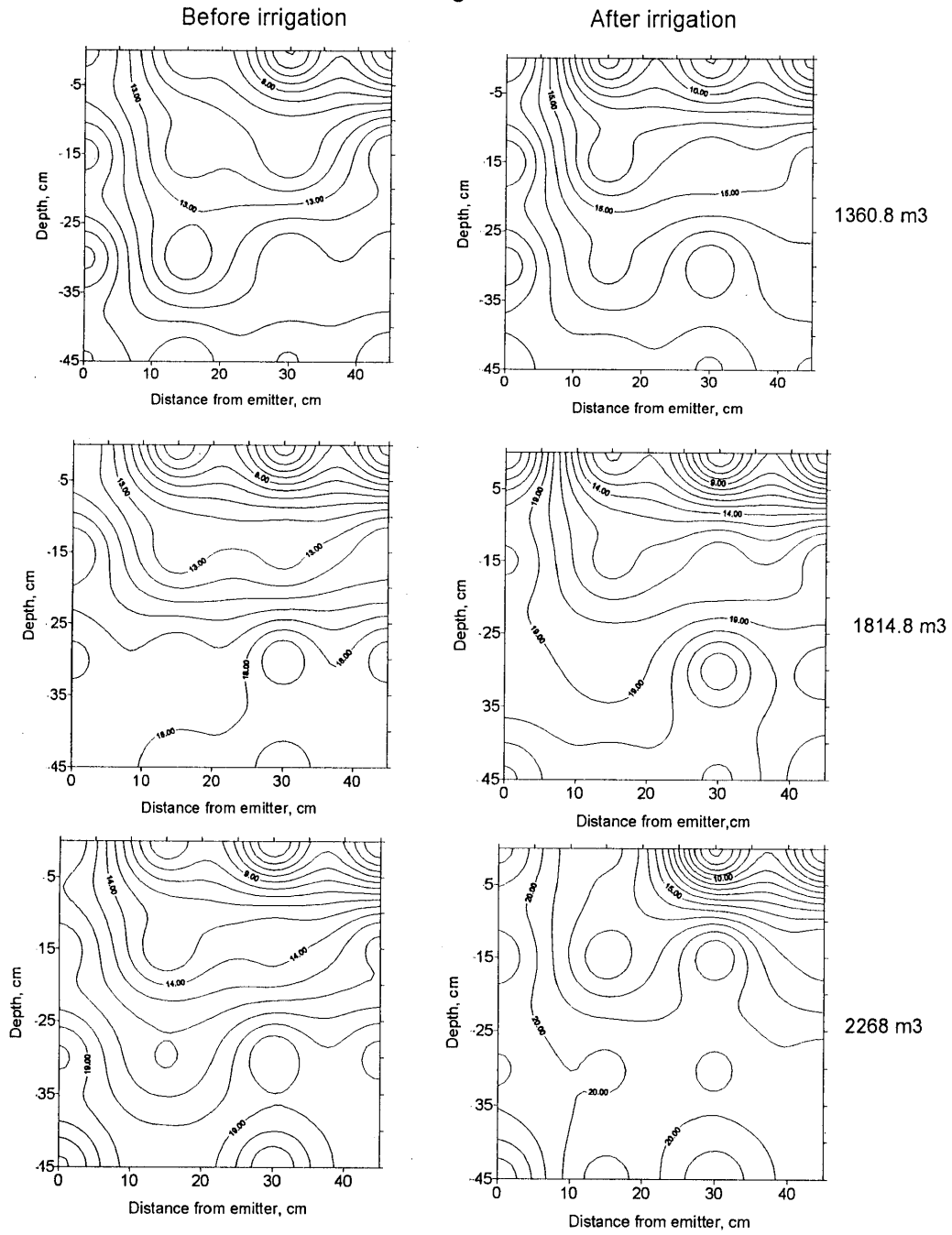


Fig.33-b: Soil moisture content and distribution as affected by applied water volume under drip irrigation at 2.85 mmhos/cm irrigation water salinity for sunflower

Across lateral

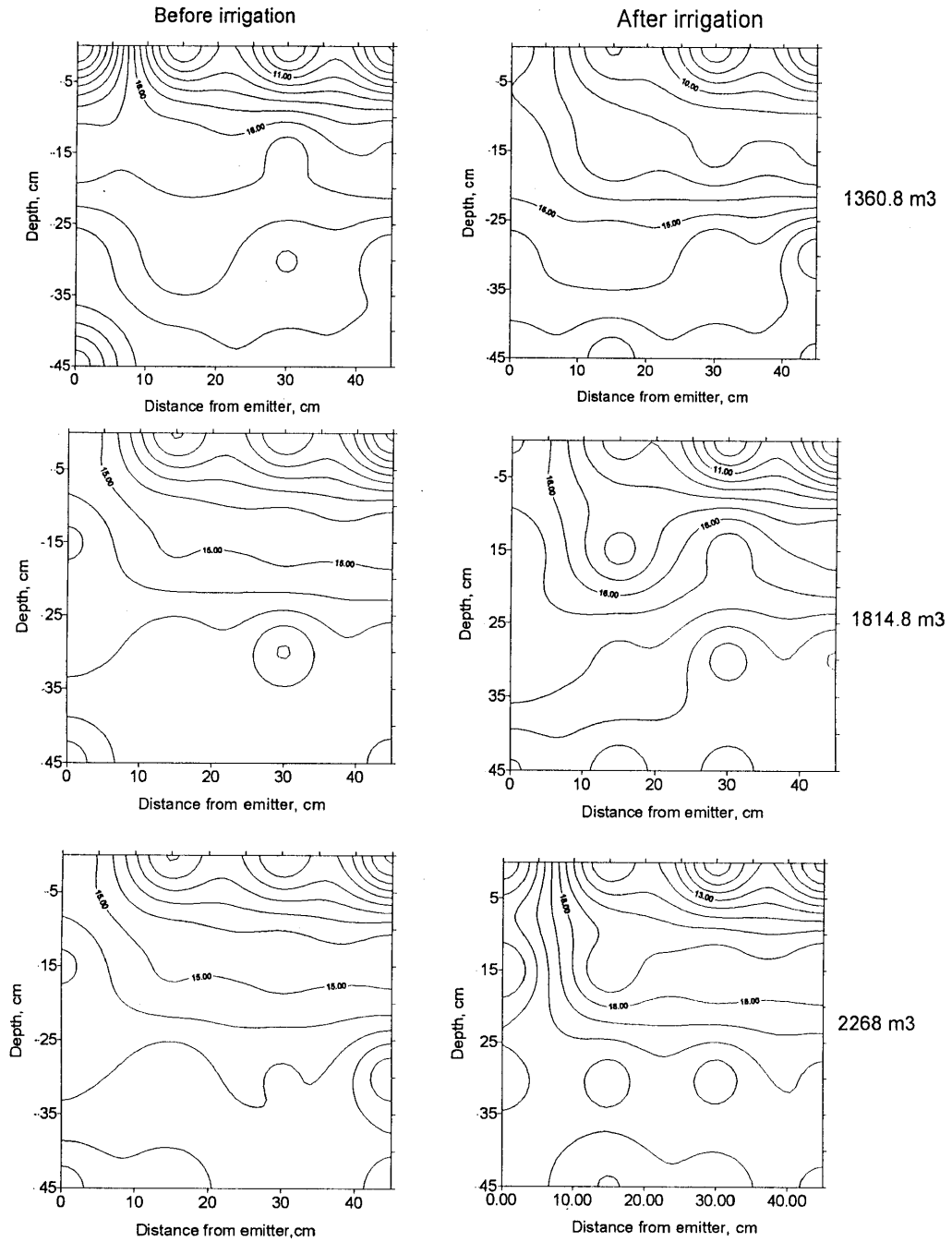


Fig.34-a : Soil moisture content and distribution as affected by applied water volume under drip irrigation at 3.61 mmhos/cm irrigation water salinity for sunflower

Along lateral

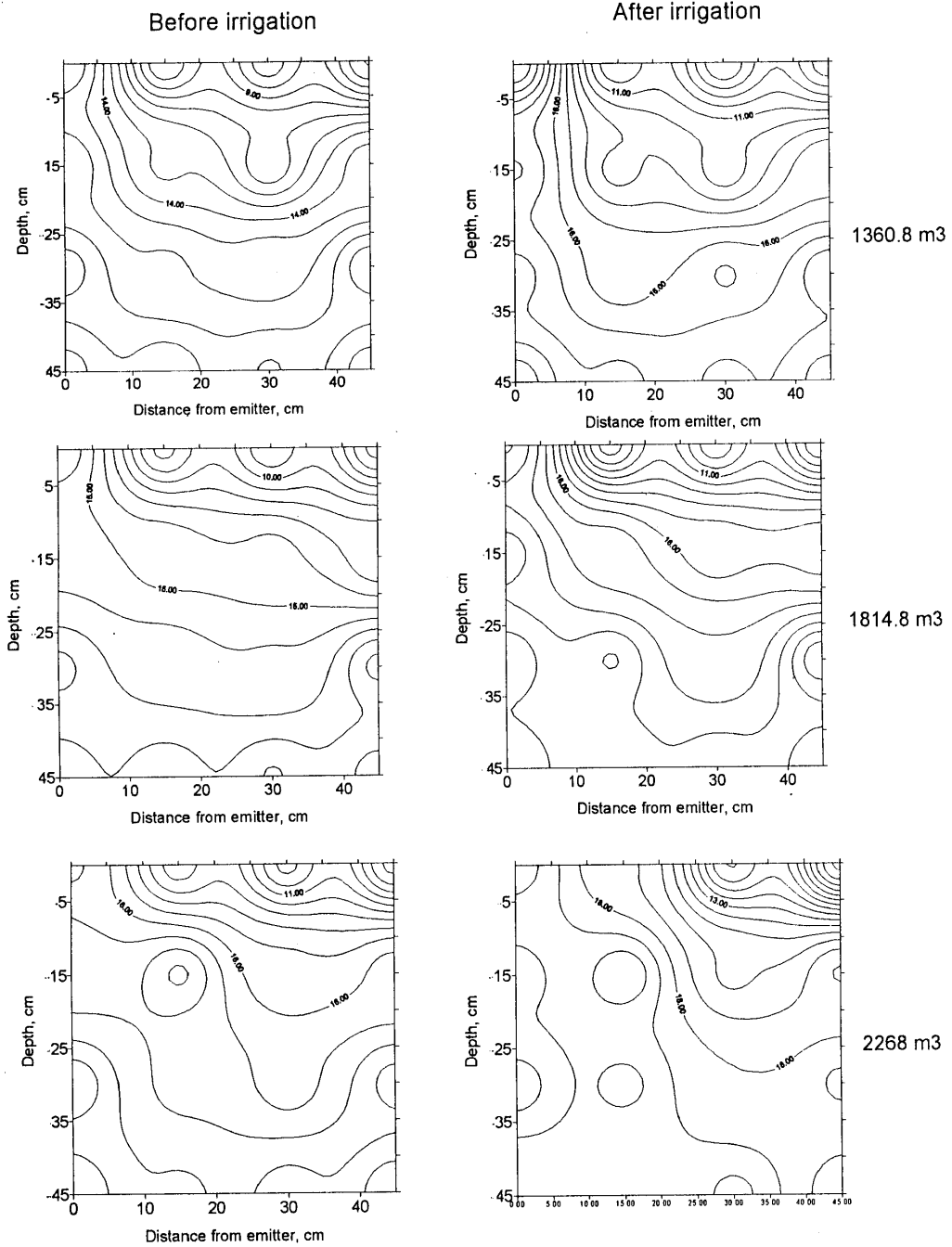
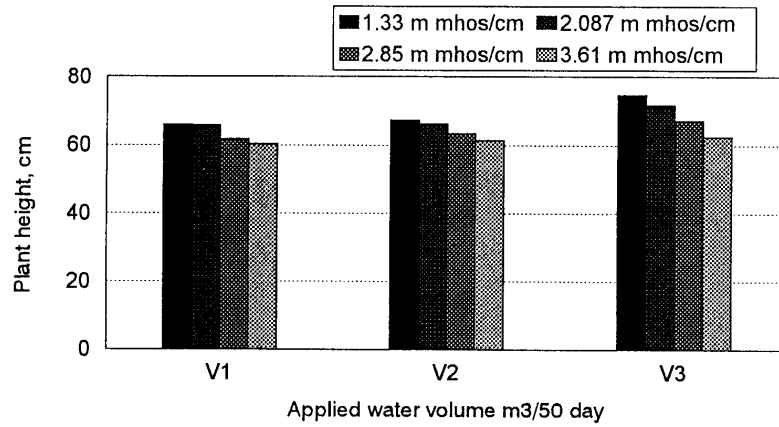
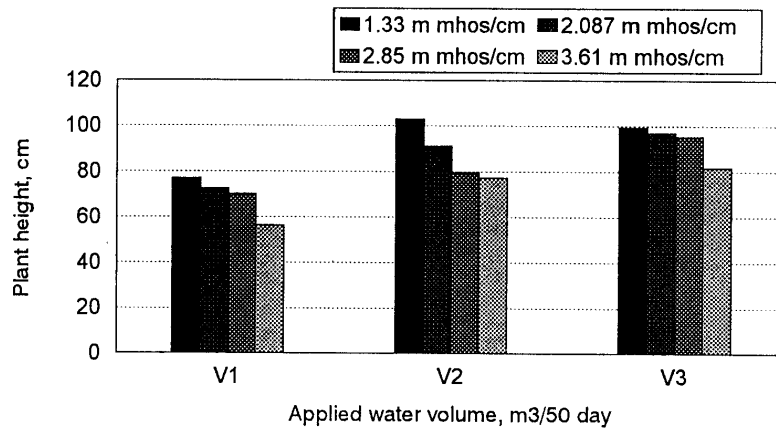


Fig.34-b: Soil moisture content and distribution as affected by applied water volume under drip irrigation at 3.61 mmhos/cm irrigation water salinity for sunflower

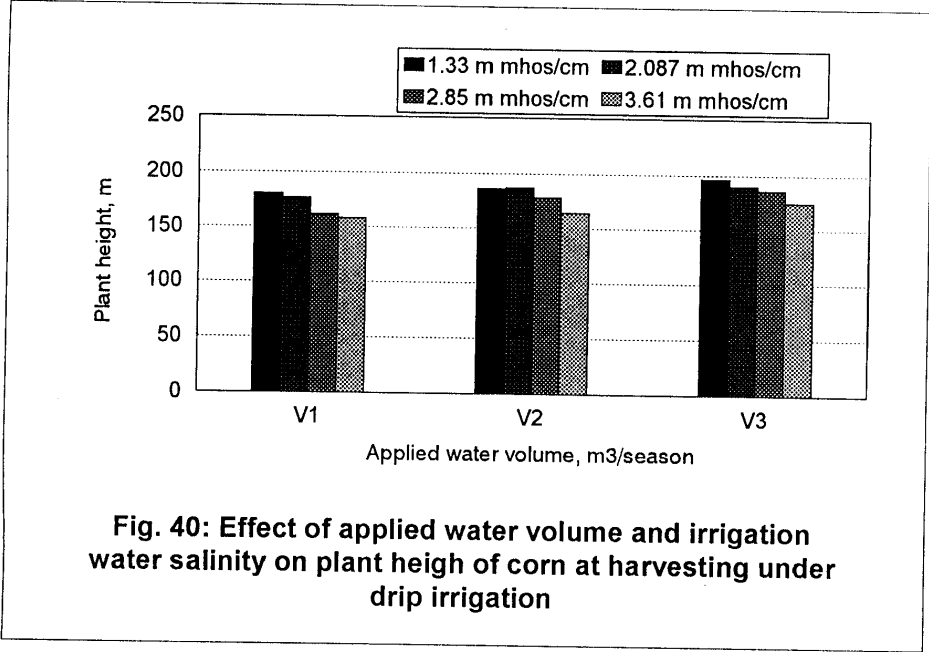
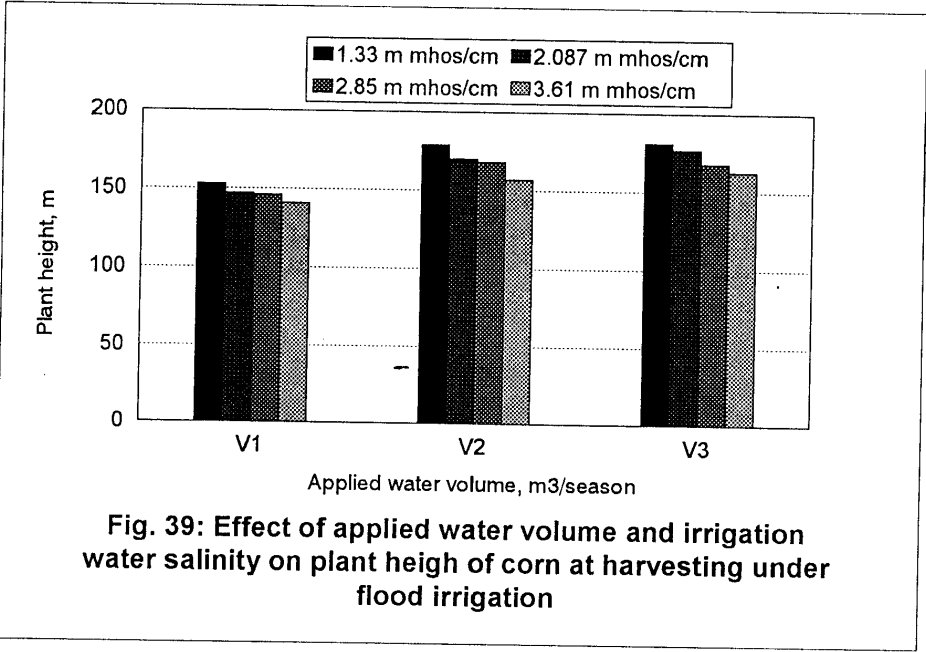


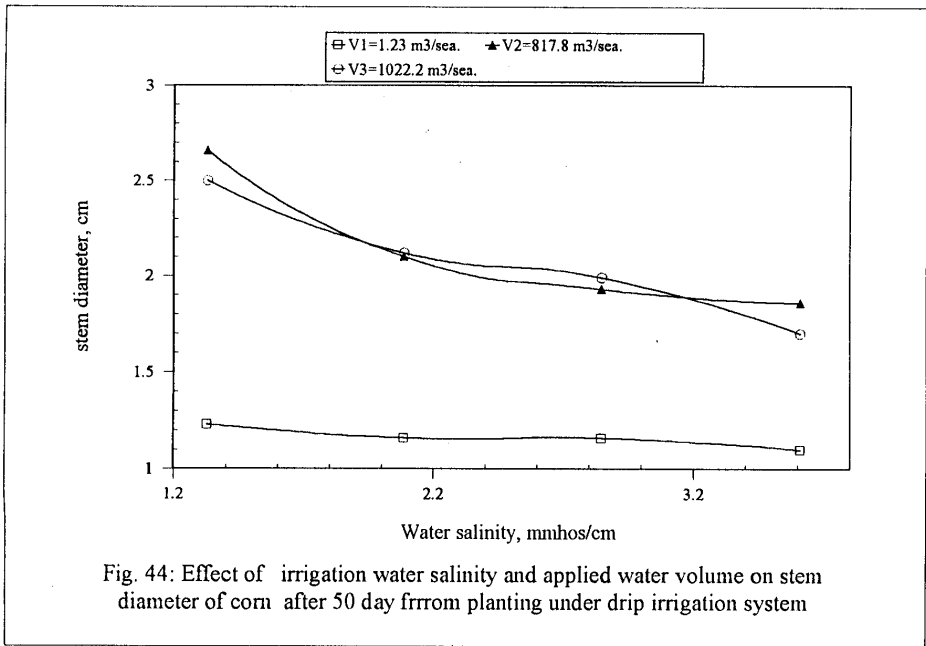
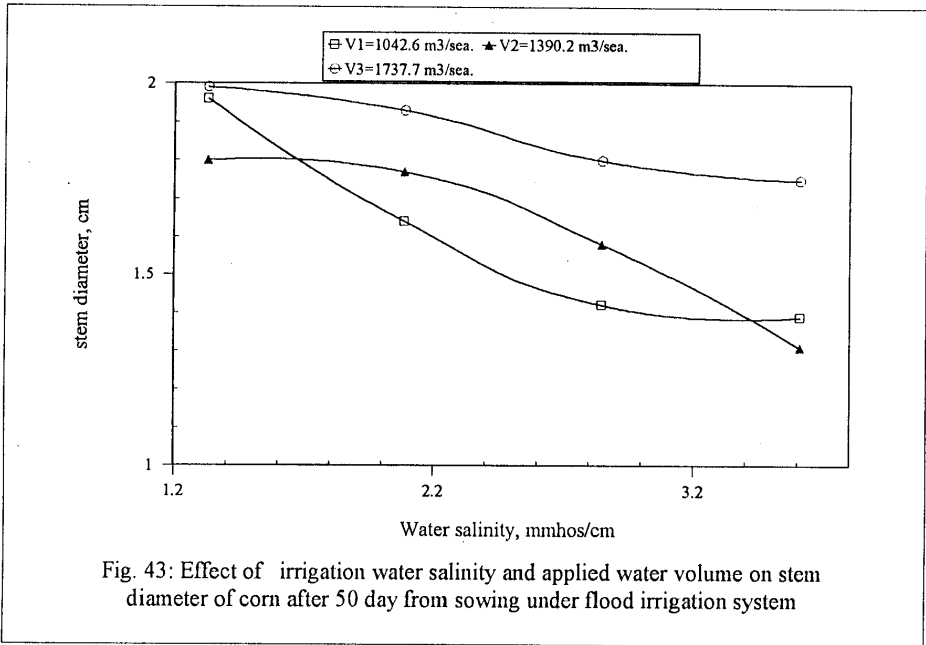
**Fig. 37: Effect of applied water volume and irrigation water salinity on corn plant height after 50 day from sowing under flood irrigation**

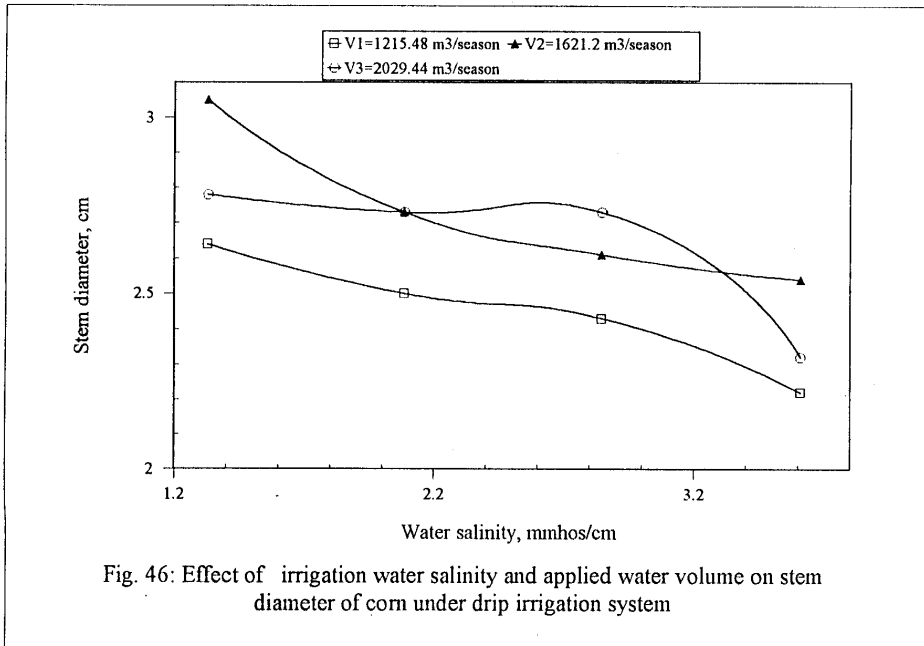
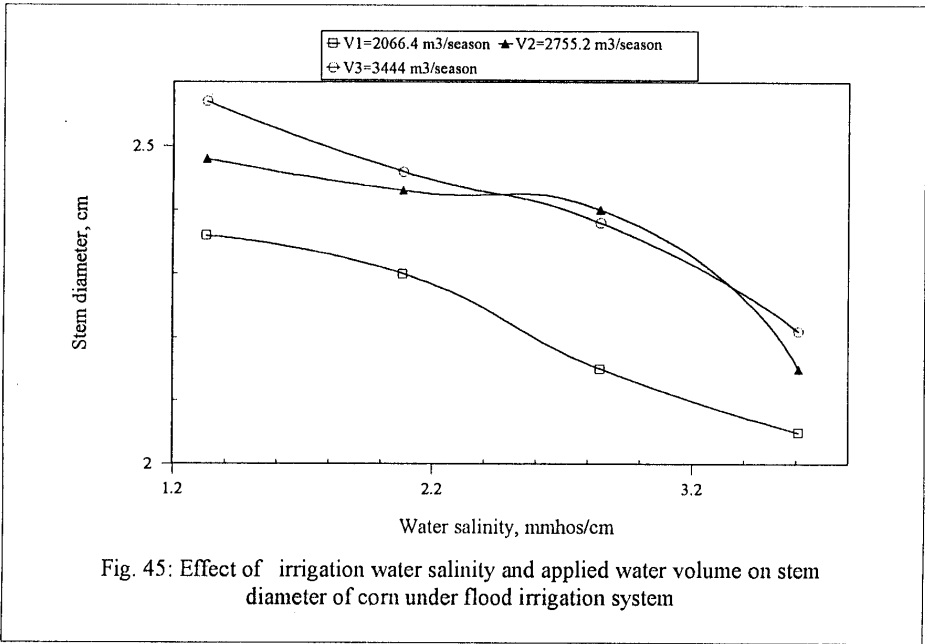


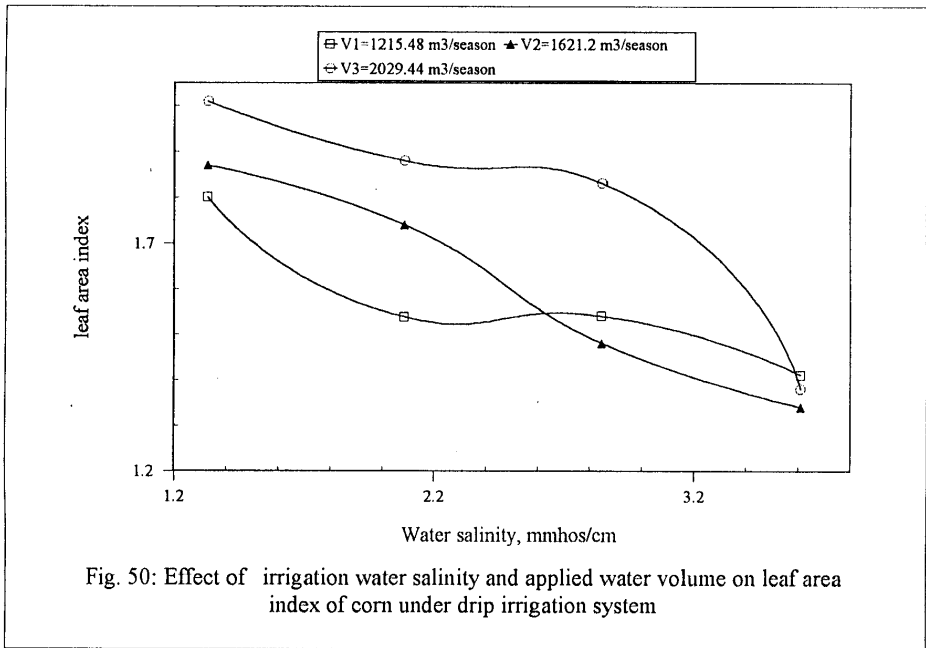
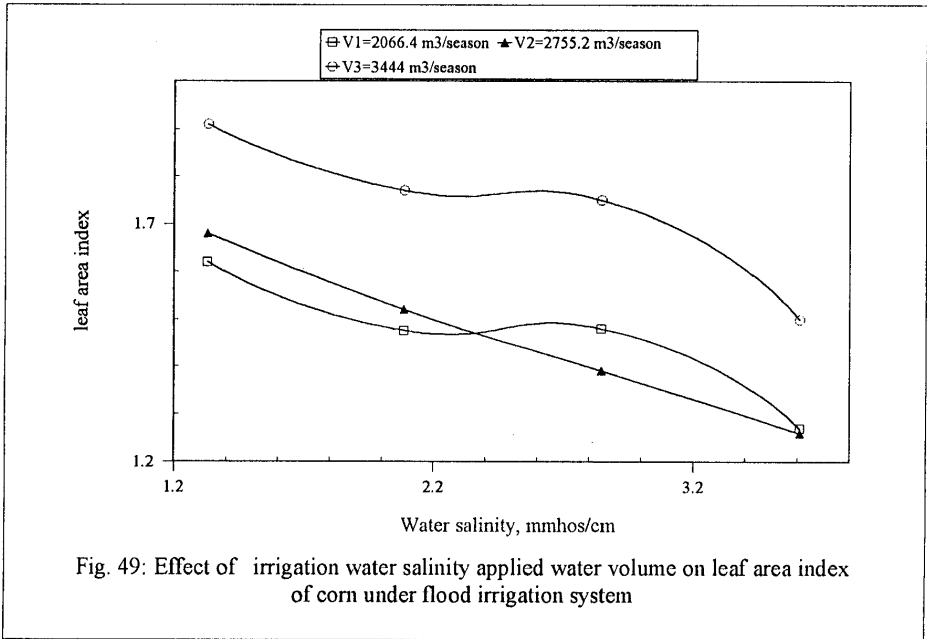
**Fig. 38: Effect of applied water volume and irrigation water salinity on corn plant height after 50 day from sowing under drip irrigation**

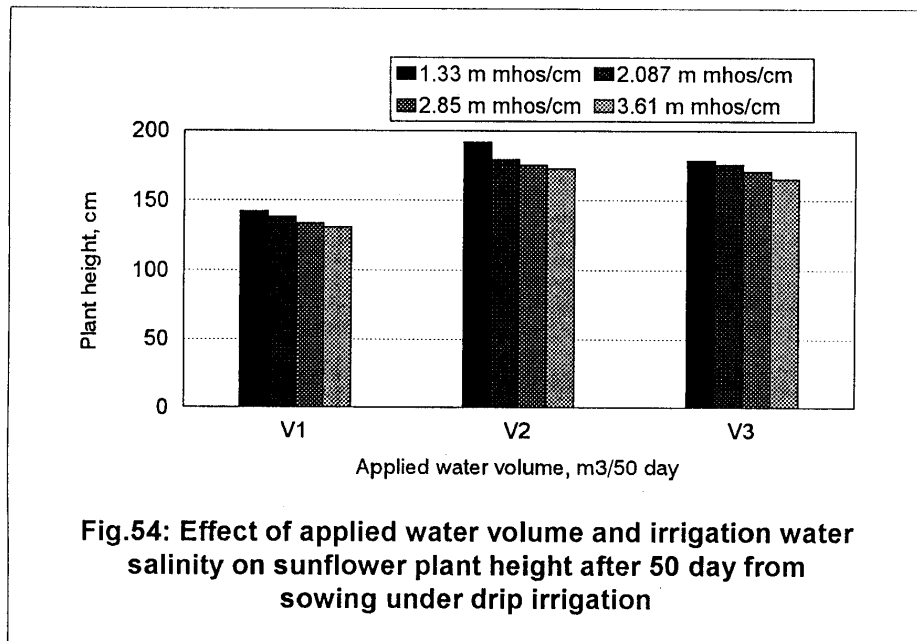
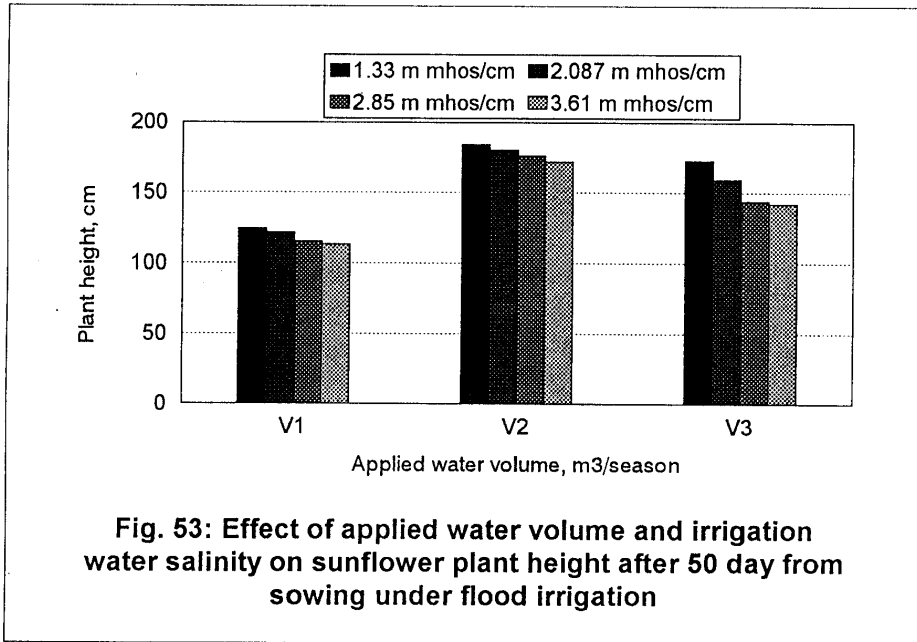


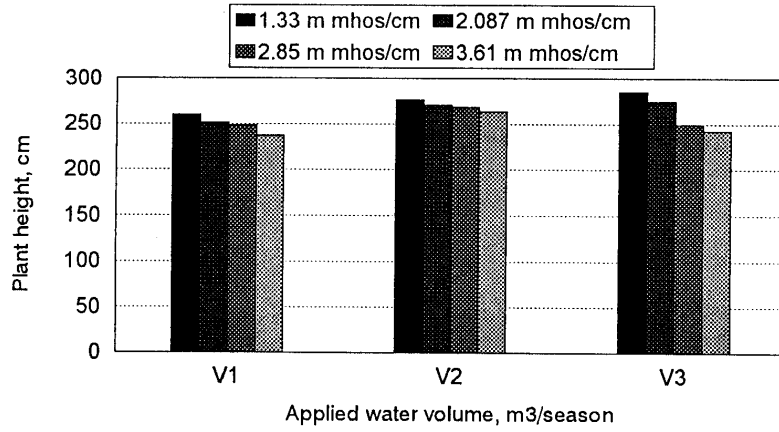




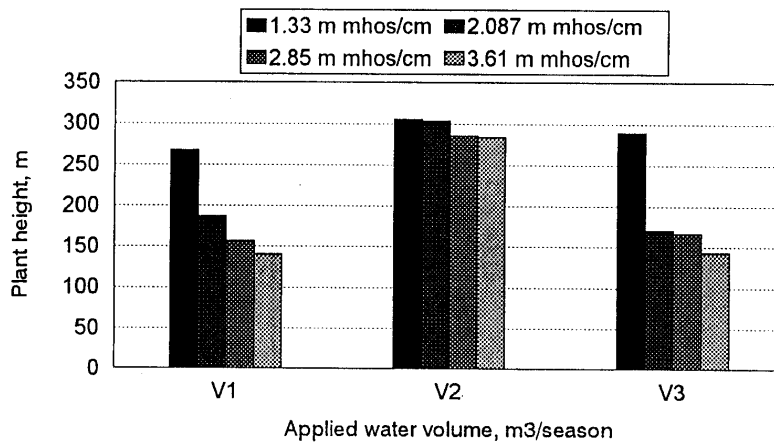




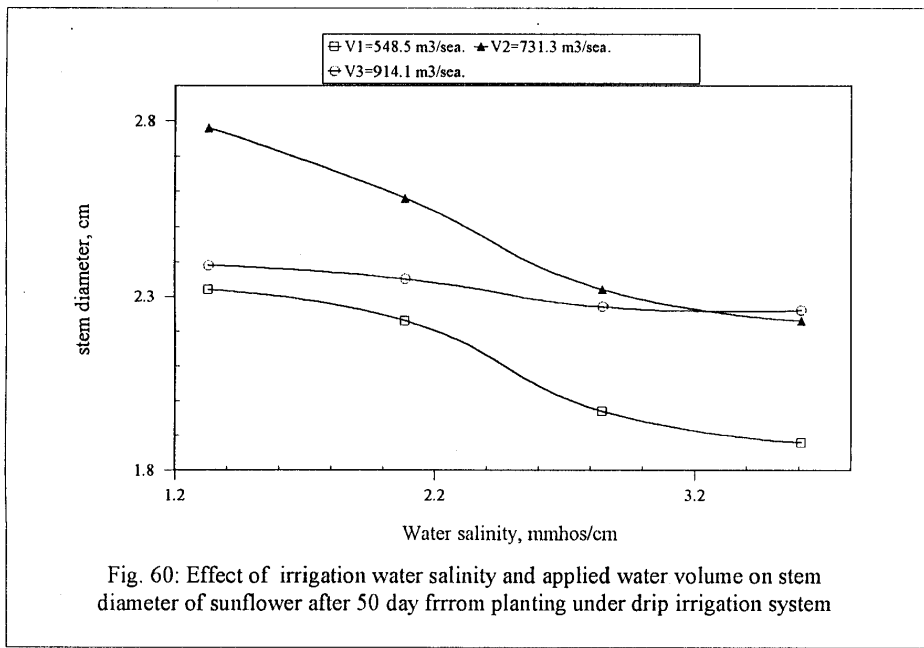
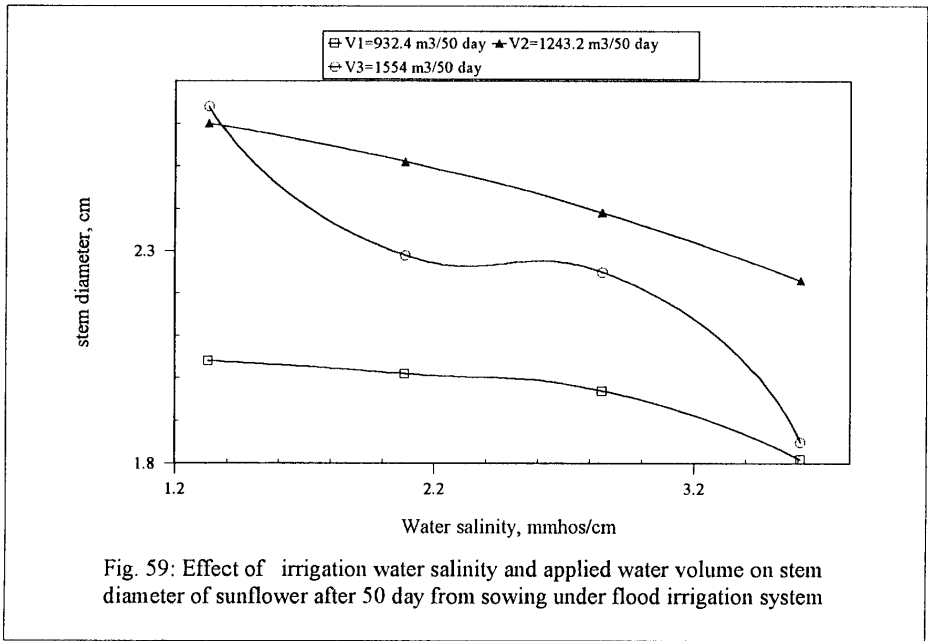


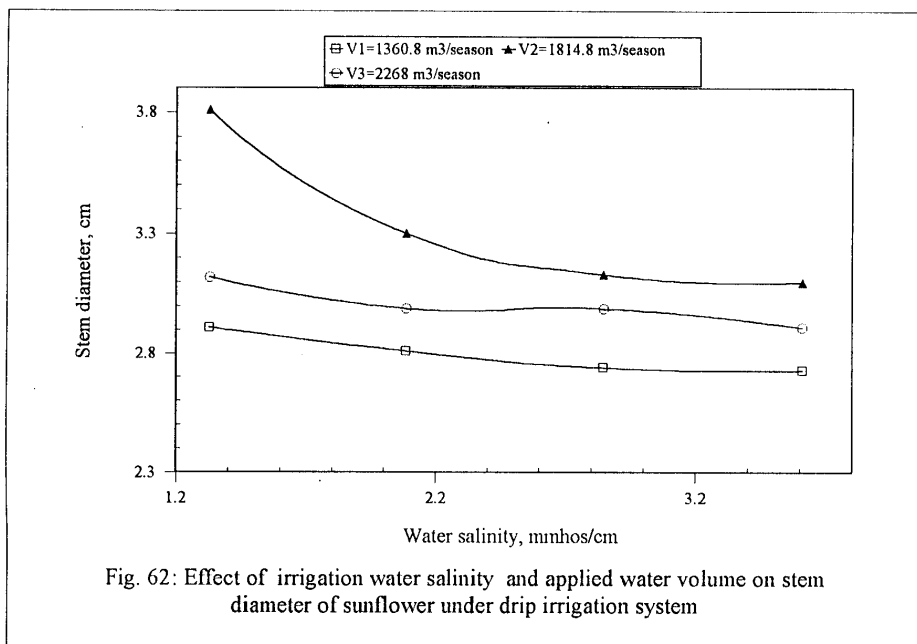
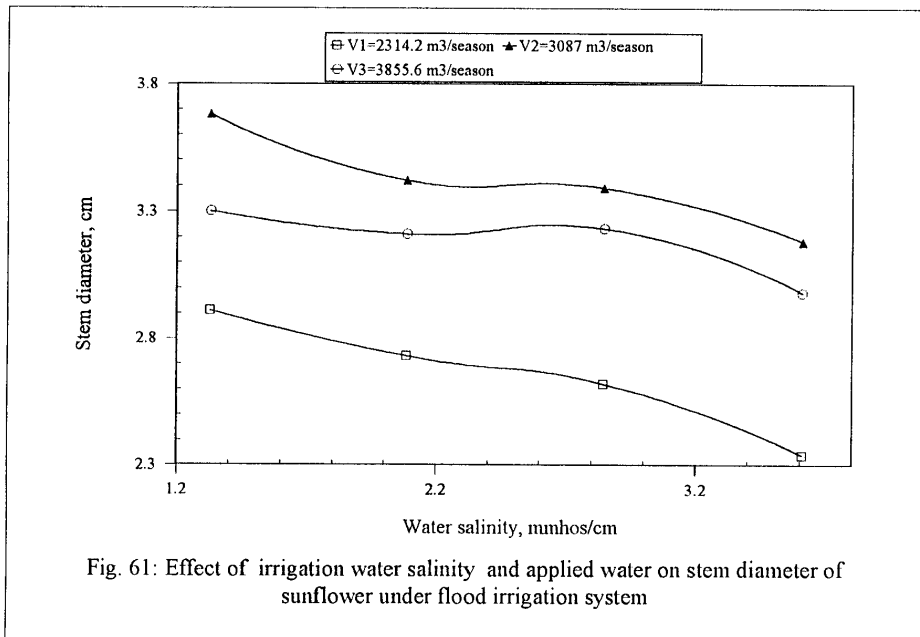


**Fig. 55: Effect of applied water volume and irrigation water salinity on plant height of sunflower at harvesting under flood irrigation**

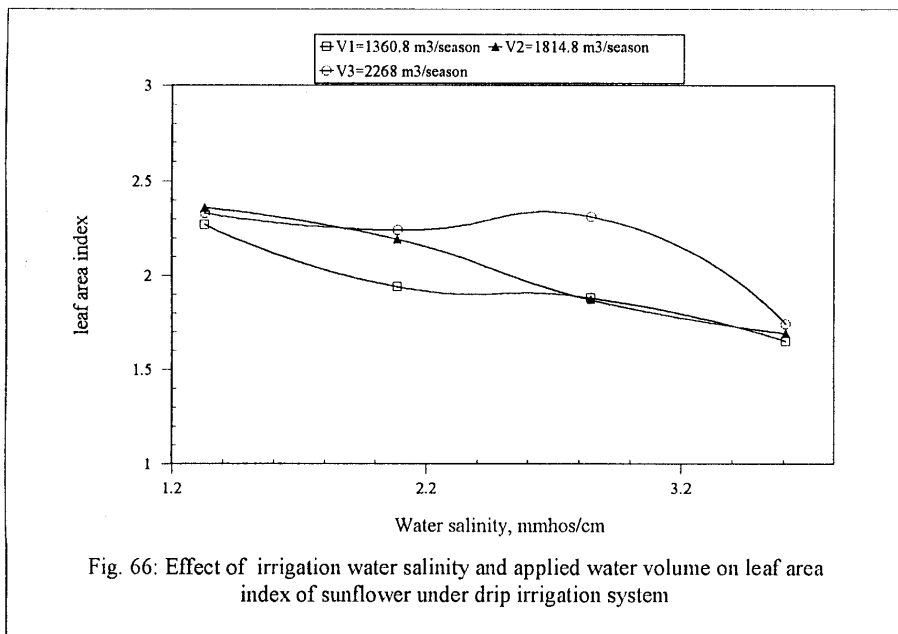
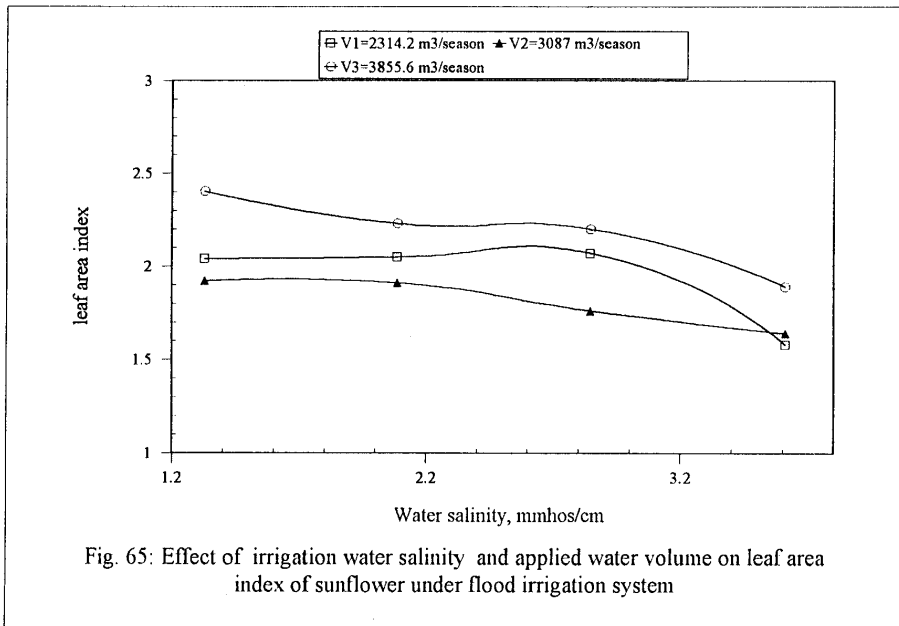


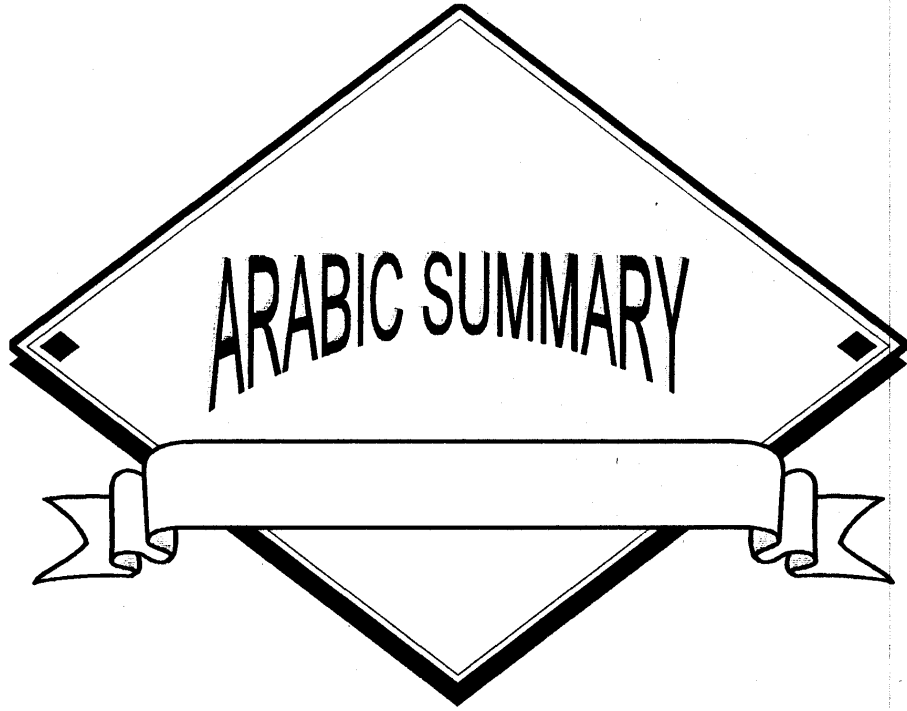
**Fig. 56: Effect of applied water volume and irrigation water salinity on plant height of sunflower at harvesting under drip irrigation**











# بسم الله الرحمن الرحيم

## الملخص العربي

دراسة على تأثير نظامين للرى و إعادة استخدام مياة الصرف على إنتاجية محصولي الذرة و عباد الشمس

أقيمت تجربة حقلية خلال الموسم الزراعى الصيفى عام ١٩٩٧ بمنطقة شمال التحرير- مركز أبو المطامير - محافظة البحيرة بهدف دراسة تأثير نظامين للرى والرى بمياه مالحة ( مياه الصرف الزراعى ) مع إضافة معدلات مختلفة من مياه الرى على بعض خواص التربة لأرض رملية لومية وكذلك على النمو الخضرى وكمية كل من محصولى الذرة الشامية وعباد الشمس . وقد استخدم فى هذه الدراسة تصميم القطع المنشقة ذو قطاعات كاملة العشوائية فى ٣ مكررات

وقد اشتملت الدراسة على نوعين من نظم الرى هما :-

أ- نظام الرى بالغمر

ب- نظام الرى بالتنقيط

كذلك احتوت الدراسة على ثلاثة معدلات لإضافة المياه وهى على النحو التالى:-

٢٠٦٦،٤ ، ٢٧٥٥،٢ ، ٣٤٤٤،٣ م<sup>٣</sup>/موسم للفدان ، ٢ ، ٢٣١٤،٢ ، ٣٠٨٧،٦ ، ٣٨٥٥،٦ م<sup>٣</sup>/موسم للفدان لكل من الذرة وعباد الشمس على الترتيب عند استخدام نظام الرى بالغمر.

١٢١٥،٤٨ ، ١٦٢١،٢ ، ٢٠٢٩،٤٤ م<sup>٣</sup>/موسم ، ٨ ، ١٣٦٠،٨ ، ١٨١٤،٨ ، ٢٢٦٨،٨ م<sup>٣</sup>/موسم للفدان لكل من الذرة وعباد الشمس على الترتيب باستخدام نظام الرى بالتنقيط.

كذلك احتوت الدراسة على أربع نوعيات مختلفة من مياه الرى كالتالى:

١- مياه رى عادية ذات ملوحة ١،٣٣ ملليموز/سم

٢- مياه صرف زراعى ذات ملوحة ٣،٦١ ملليموز/سم

٣- مياه مخلوطة بنسبة ٢ مياه عادية : ١ مياه صرف بالحجم ذات ملوحة ٢،٠٨٧ ملليموز/سم

٤- مياه مخلوطة بنسبة ٢ مياه صرف : ١ مياه رى عادية بالحجم ذات ملوحة ٢،٨٥ ملليموز/سم

ويمكن تلخيص النتائج المتحصل عليها كالتالى:

### ١- ملوحة التربة وتوزيعها :

أوضحت النتائج المتحصل عليها انه عند استخدام مياة عالية الملوحة ( مياة الصرف ) أدى ذلك الى زيادة ملوحة التربة وقد قلت تلك الملوحة كلما قل تركيز الأملاح فى مياة الرى وكانت ملوحة التربة كذلك

تقل بزيادة كمية ماء الري المضافة . وفي نظام الري بالغمر فان ملوحة التربة تزداد بزيادة العمق وذلك بعد إتمام عملية الري أى زيادة رأسية ولكن في حالة استخدام نظام الري بالتنقيط فان ملوحة التربة تزداد في الاتجاهين الرأسى والأفقي ( تزداد مع العمق وكذلك كلما بعدنا عن النقاط). وأدى نظام الري بالتنقيط الى نقص الملوحة في هذه المنطقة مقارنة بنظام الري بالغمر وذلك لانه يحافظ على محتوى رطوبى مناسب في منطقة الجذور مما يؤدي الى تقليل الملوحة.

## ٢-المحتوى الرطوبى وتوزيعه في التربة :

لوحظ أن قيم المحتوى الرطوبى في التربة تنخفض بزيادة عمق التربة وذلك بعد إتمام عملية الري تحت كلا النظامين: نظام الري بالغمر ونظام الري بالتنقيط وكذلك تنخفض قيم المحتوى الرطوبى كلما بعدنا عن النقاط في حالة الري بالتنقيط. والري بالتنقيط يوفر الرطوبة المناسبة لنمو النباتات في منطقة الجذور وكذلك يوفر في الاحتياجات المائية للمحصولين دون حدوث فواقد تسرب للمياه حيث انه فقد بلغت نسبة الوفرة حوالى ٤١ ٪ من المياه مقارنة بالرى بالغمر. وجد أيضا أنه بزيادة حجم ماء الري المضاف فان قيمة حجم التربة المبتل يزداد.

## ٣-النمو الخضرى لمحصولى الذرة وعباد الشمس :

### ٣-١الذرة

أوضحت النتائج أن استخدام مياه عالية الجودة ( مياة الترعة ) أعطت أعلى نمو خضرى لنبات الذرة بغض النظر عن العوامل الأخرى حيث كان لها تأثير كبير على ارتفاع النبات وقطر الساق ومساحة سطح الأوراق عند مراحل النمو المختلفة. كذلك فان كميات المياه المضافة ونظام الري المتبع كان لهما تأثير كبير على النمو الخضرى . ووجد أن استخدام نظام الري بالتنقيط يوفر الرطوبة المناسبة لنمو النبات وكذلك التحكم في إضافة السماد مما يؤدي الى نمو خضرى جيد.

### ٣-٢عباد الشمس :

أوضحت النتائج أيضا أن استخدام مياه عالية الجودة ( مياة الترعة ) أعطى أعلى نمو خضرى بغض النظر عن العوامل الأخرى، حيث أعطت أعلى ارتفاع للنبات وقطر الساق ومساحة سطح الأوراق على طول موسم النمو. كذلك فان اختلاف كميات مياة الري المضافة كان له تأثير على النمو الخضرى لمحصول عباد الشمس .

#### ٤- كمية المحصول:

##### ٤-١ محصول الذرة :

أوضحت النتائج ان نظام الري بالتنقيط وكذلك استخدام مياه عالية الجودة ( مياة الترعة ) عند استخدام أعلى معدل لإضافة المياه وهو  $29,44 \text{ م}^3$  / موسم. فدان أعطى أعلى محصول للذرة  $6,150$  ميغا جرام/فدان. أوضحت الدراسة ان نظام الري بالتنقيط يعتبر افضل نظم الري حيث انه يوفر حوالى  $41\%$  من كمية مياة الري مقارنة بنظام الري بالغمر وكذلك فان نظام الري بالتنقيط يعطى محصولا أعلى من نظام الري بالغمر خاصة عند استخدام مياه عالية الملوحة بملوحة  $1,33$  ملليموز/سم وانه أدى الى زيادة محصول الذرة بنسبة  $9,75\%$  مقارنة بنظام الري بالغمر.

##### ٤-٢ محصول عباد الشمس :

أوضحت النتائج أن أعلى محصول لعباد الشمس  $1,143$  ميغا جرام/فدان كان في القطع التي رويت باستخدام نظام الري بالغمر مع استخدام مياة عالية الجودة ( مياة الترعة ) وكذلك عند استخدام معدل إضافة مياه قدره  $30,87 \text{ م}^3$  / موسم. فدان. وجد كذلك ان نظام الري بالغمر يعطى محصول أعلى من نظام الري بالتنقيط. كذلك وجد أن استخدام نظام الري بالغمر أدى الى نسبة زيادة في محصول عباد الشمس قدرها  $8,75\%$  مقارنة بنظام الري بالتنقيط.

#### ٥- كفاءة استخدام المياه :

بعد إتمام التجربة لوحظ أن استخدام نظام الري بالتنقيط أعطى أعلى قيمة لكفاءة استخدام المياه مع مياة الري الجيدة ( مياه الترعة ) واقل معدل لإضافة المياه لكل من الذرة وعباد الشمس. وكانت أعلى قيمة لها هي  $67$  كجم /  $\text{م}^3$  ،  $3,81$  كجم /  $\text{م}^3$  لكل من محصولي عباد الشمس والذرة على الترتيب بينما كانت اقل قيمة لها عند استخدام نظام الري بالغمر مع مياه الصرف ( بملوحة  $3,61$  ملليموز/سم) أعلى معدل لإضافة المياه وكانت اقل قيمة لكفاءة استخدام المياه هي  $18$  كجم /  $\text{م}^3$  ،  $1,43$  كجم /  $\text{م}^3$  لكل من محصولي عباد الشمس والذرة على الترتيب. كذلك فان نظام الري بالتنقيط يعطى أعلى قيم لكفاءة استخدام المياه مع توفير حوالى  $41\%$  من مياه الري مقارنة بنظام الري بالغمر وانه أدى الى زيادة كفاءة استخدام المياه بنسبة  $43,8$  ،  $35,8\%$  لكل من الذرة وعباد الشمس على الترتيب مقارنة بنظام الري بالغمر.

## ٦- توصيات تطبيقية

خلال الموسم الزراعى الصيفى ١٩٩٧ تم تنفيذ التجربة فى منطقة شمال التحرير. ومن خلال النتائج المتحصل عليها يمكن ذكر التوصيات الآتية:-

- ١- مياه الصرف يمكن إعادة استخدامها بعد خلطها بالمياه العذبة (مياه الترعة) فى هذه المنطقة
- ٢- إذا أراد المزارع فى هذه المنطقة زراعة محصول الذرة يوصى باستخدام نظام الري بالتنقيط حيث انه يعطى أعلى إنتاجية للذرة مقارنة بنظام الري بالغمر ولكن إذا أراد زراعة محصول عباد الشمس يوصى باستخدام الري بالغمر حيث أعطى أعلى إنتاجية من المحصول مقارنة بنظام الري بالتنقيط
- ٣- إذا أراد المزارع اضافة معدلات الري المناسبة فى تلك المنطقة لزراعة محصولي الذرة وعباد الشمس فهى ٢٠٢٩,٤٤ م<sup>٣</sup>/موسم للفدان بنظام الري بالتنقيط ، ٣٠٨٧ م<sup>٣</sup>/موسم للفدان بنظام الري بالغمر على التوالي.
- ٤- نظام الري بالتنقيط سوف يوفر للمزارع فى ذات المنطقة ٤١ ٪ من متطلبات المياه مقارنة بالري بالغمر.

# إعادة استخدام مياه الصرف مع نظم ري مختلفة

## دراسة على تأثير نظامين للري وإعادة استخدام مياه الصرف على إنتاجية محصولي الذرة وعباد الشمس

رسالة مقدمة من

**عادل محمد هلال المتولى**

للحصول على درجة الماجستير في

العلوم الزراعية (ميكنة الزراعية)

لجنة المناقشة والحكم على الرسالة:

.....  
الأستاذ الدكتور/ محمد نبيل العوضى  
أستاذ الهندسة الزراعية - كلية الزراعة - جامعة عين شمس

.....  
الأستاذ الدكتور/ متولى متولى محمد  
أستاذ الهندسة الزراعية ورئيس مجلس قسم الميكنة الزراعية - كلية الزراعة بكفر الشيخ -  
جامعة طنطا

.....  
الأستاذ الدكتور/ ممدوح عباس حلمي  
أستاذ الهندسة الزراعية - كلية الزراعة بكفر الشيخ - جامعة طنطا

.....  
الدكتور/ سمير محمود جمعة  
أستاذ الهندسة الزراعية المساعد - كلية الزراعة بكفر الشيخ - جامعة طنطا

التاريخ ١٩٩٩/ ٦/ ٨

٥٢١  
٥٢١

دراسة على تأثير نظامين للرى واعادة استخدام مياه  
الصرف على إنتاجية محصولى الذرة وعباد الشمس



مقدمة من

عادل محمد هلال المتولى

بكالوريوس فى العلوم الزراعية (هندسة زراعية)

كلية الزراعة - جامعة الاسكندرية ١٩٩٣

رسالة مقدمة

كجزء من المتطلبات للحصول على درجة الماجستير

فى

العلوم الزراعية - الميكنة الزراعية

من

قسم الميكنة الزراعية

كلية الزراعة بكفر الشيخ

جامعة طنطا

١٩٩٩