

٥٦٥

جامعة الإسكندرية  
مكتبة  
كلية الطب البيطري بأسيوط

**HORMONAL INDUCTION OF SPAWNING IN  
AFRICAN CATFISH (Clarias lazera)**

**THESIS PRESENTED**

**By**

**ISMAIL ISMAIL YOUSEF ABO-GHANEMA**

**(B. V. Sc., 1994)**

**Alexandria university**

**For**

**The Degree of M. V. Sc**

**To**

**University of Alexandria**

**Faculty of Veterinary Medicine**

**Department of Animal Physiology**

**(1999)**

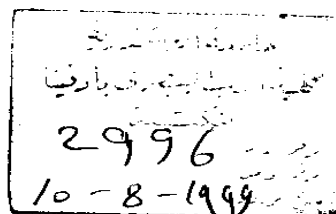

**Under the supervision of**

**Prof.Dr. Samir A. Ghannam**

*Prof. Of Phystology*

**Faculty of veterinary medicine**

**Alexandria University**

**Prof.Dr. Bahig R. Nemetallah**

*Prof. Of Phystology*

**Faculty of veterinary medicine**

**Alexandria University**

**Dr. Mohey El-Deen M. Abd Allah**

*Assist. Prof Of Phystology*

**Faculty of veterinary medicine**

**Alexandria University**

**Dr. Sobhy A. Hedaya**

*Assist. Pr of. Of Phystology*

**Faculty of veterinary medicine**

**Alexandria University**

بسم الله الرحمن الرحيم

قرار لجنة الحكم والمناقشة

قامت لجنة الحكم والمناقشة بفحص الرسالة وترى أنها اشتملت على بحثا هادفا ومواضيع لها أهميتها في مجال فسيولوجيا الحيوان كما قامت اللجنة بمناقشة المتقدم مناقشة مستفيضة ووجدت أن الطالب ملما إماما كاملا بكل ماجاء بها.

\_\_\_\_\_ ذلك

قررت اللجنة ترشيح السيد ط.ب/ إسماعيل إسماعيل أبو غنيمة للحصول على درجة الماجستير في العلوم الطبية البيطرية (تخصص: فسيولوجيا الحيوان).

التوقيع

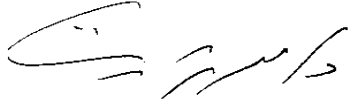

اللجنة

د.أ/ علي عبد المقصود فرحات

أستاذ الفسيولوجيا - كلية الطب البيطري  
جامعة القاهرة



د.أ/ عبد الدايم زكريا محمد علي

أستاذ الفسيولوجيا - كلية الطب البيطري  
جامعة الإسكندرية

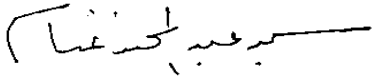

د.أ/ سمير عبد المجيد غنام

أستاذ الفسيولوجيا - كلية الطب البيطري  
جامعة الإسكندرية والمشرف على الرسالة



د.أ/ بهيج رياض نعمة الله

أستاذ الفسيولوجيا - كلية الطب البيطري  
جامعة الإسكندرية والمشرف على الرسالة



د/ صبحي عبد العزيز حداية

أستاذ الفسيولوجيا المساعد - كلية الطب البيطري  
جامعة الإسكندرية والمشرف على الرسالة

## **ACKNOWLEDGMENT**

*I would like to express my sincere gratitude to Prof Dr. Samir A. Ghannam Professor of Physiology Faculty of Veterinary Medicine Alexandria university for his supervision, guidance, fruitful advises, great help and encouragement. Best thanks are due to Prof Dr. Bahig R. Nemetallah, Professor of Physiology Faculty of Veterinary Medicine Alexandria University for his supervision, great support, very kind encouragement and scientific guide, during the preparation of this thesis.*

*Thanks are also due to Dr. Mohey El-Deen M. Abd Allah, Assistant Professor of Physiology Faculty of Veterinary Medicine Alexandria University for his supervision and valuable help.*

*Best thanks are due to Dr. Sobhy Abd El-Aziz Hoyada, Assistant Professor of Physiology Faculty of Veterinary Medicine Alexandria University for his stimulating supervision, helpful advice and encouragement.*

*Heartly thanks are due to Dr. Nabil A. Heahal Assistant Professor of Physiology Faculty of Veterinary Medicine Mansura University for his support and encouragement.*

*Heartly thanks are due to all members of the Department of Physiology, Pharmacology and biochemistry, Faculty of Veterinary Medicine Alexandria University for their valuable help.*

# CONTENTS

	<b>Pages</b>
<b>INTRODUCTION .....</b>	<b>1</b>
<b>REVIEW OF LITERATURE .....</b>	<b>3</b>
<b>MATERIALS AND METHODS .....</b>	<b>27</b>
<b>RESULTS .....</b>	<b>35</b>
<b>DISCUSSION .....</b>	<b>46</b>
<b>SUMMARY .....</b>	<b>54</b>
<b>REFERENCES</b>	<b>58</b>
<b>ARABIC SUMMARY</b>	

# **INTRODUCTION**

---

## INTRODUCTION

There is increased demand for searching to obtain a cheap protein of animal origin for human consumption. Fish and fish products are considered one of the most important food stuffs as they are the cheapest source of high quality animal protein as well as its richness in calcium, phosphorous, iodine and vitamins.

Catfish (Karmout) is one of the most important economic fish species in our country due to its highest growth rate (*Legendre, 1983*). It is also highly resistant to adverse conditions and its performances in monoculture are very economic (*Dia et al., 1986*).

Catfish of the genus *Clarias* are well represented in Africa, Syria and Southeastern Asia. About 32 species are known in Africa in this genus (*Boulenger, 1907*). *Clarias lazera* and *Clarias anguillaris* are the most common species in land water fishes found in Egypt. *Clarias lazera* is one of the endogenous fish species in the Nile river. It is common in the Nasser lake and all Nile branches, streams and irrigation canals as well as the brackish coastal Delta lakes, Manzalah, Burullus, Idku and Maryut (*Dowider et al., 1985*).

Among the most significant advancement in the field of aquaculture during recent years is the development of techniques to induce reproduction in fish (*Staff., 1983*). Successful induced breeding of

---

fish using different substances with direct or indirect gonadotropic action has been reported for several species (*Lam., 1982*).

Induced breeding in African catfish (*Clarias lazera* ) by supplementing gonadotrophin hormone (GTH) exogenously in the form of crude pituitary extract is a common practice (*Eding et al., 1982*).

Induced ovulation followed by artificial fertilization is generally used in different fish species which can undergo natural spawning in captivity to achieve a greater control over fry production (*Legendre, 1986*)

The aim of the present work is: -

- 1- To study the effect of some hormones on oocyte maturation in vitro.
- 2- To achieve a greater control on fry production by mean of artificial fertilization in vitro .



---

**REVIEW OF LITERATURE**

The fresh water catfish (*Clarias lazera*) is one of the common fish species in Egypt. It is an economic fish due to its high growth rate even in adverse environment. The breeding season of *Clarias lazera* in Egypt extends from April to October with maximum activity during June (*Dowider et al., 1985*).

**Development and structure of the testis: -**

In most teleosts, the testes are paired and elongated and are suspended from the dorsal body wall by mesorchia. A system of internal efferent ducts is usually present. The efferent ducts are short in acinar testis as in *Poecilia reticularis* (*Pandy, 1969*), while they ramify extensively in tubular testes as in *Fundulus heteroclitus* (*Mathews, 1938*) and in *Selbastodes paucispinis* (*Moser, 1967*).

The testis consists of a number of seminiferous lobules that may be intricately branched in *Eucalia inconstyans* (*Ruby and McMillan, 1975*). In teleosts, the testis unit is the lobule and there is no permanent germinal epithelium, merely isolated nests of primary spermatogonia are present. These are associated with cells similar to Sertoli cells (*Stanley et al., 1965*) The interlobular spaces are occupied by blood vessels, nerve fibers, fibroblasts, collagen and elastic fibers and smooth muscle fibers may be

present, which presumably are involved in the dehiscence of the lobules to release mature sperm (*Gresik, 1973*).

Interstitial cells, similar to Leydig cells, in the teleosts testis have been described in *Oryzias latipes* (*Gresik, 1973*), *Carrasius auratus* (*Yamazaki and Donaldson, 1968*), *Fundulus heteroclitus* (*Bara, 1969*) and in *Tilapia* species (*Hyder and Kirschner, 1969*).

*Marshall and Lofts (1956)* were the first to describe another type of glandular cells forming the walls of mature lobules in pike (*Esox lucius*) testis. These cells were shown to contain cholesterol-positive lipid and considered as homologous to Leydig type interstitial cells, which are not found. Similar cells have now been identified in a number of teleosts species, including *Coveruis plumbeus* (*Ahsan, 1966*).

#### **Periodicity of testicular development.**

*Bruton (1979)* have studied the annual reproductive cycle in the African catfish which can be divided into three periods, i.e. the breeding period, the resting period and a period of full gametogenesis.

During the resting period (from September to March), the mean gonadosomatic index (GSI) (gonad weight in gm X 100 / body weight in gm) is low and the testes contain small

seminiferous tubules with primary spermatogonia and clusters of old sperm cells.

During the period of full spermatogenesis (in April), the mean GSI is significantly higher than in resting period, the seminiferous tubules were swollen and contain cysts with secondary spermatogonia, spermatocytes and spermatids. The lumen of some tubules containing a few spermatids and ripe sperm cells (*Van Oordt et al., 1987*).

The breeding period (from May to August), the mean GSI didn't differ significantly from those in the period of full spermatogenesis. Seminiferous tubules predominately contained cysts with spermatocytes and spermatids. Their lumen were filled with spermatids and ripe cells (*Resink et al., 1987 a;b*)

#### Development and structure of the ovary :-

The teleost ovary ,unlike that of the other vertebrates, the gonads primordium in these fishes appears to represent the cortical component in other vertebrates and the oviducts are the prolongation of the ovarian wall which open either into a cloaca or separately , to the outside. In some species, the ovary is a closed sac communicating only with its duct. In others, the follicles are exposed to the body cavity, ducts being present only as short funnels. In the former, the eggs are ovulated into the ovarian

---

cavity, whereas in the latter they are shed into the body cavity. Teleost ovaries show striking differences in gross morphology between species, and even within the species, they are different at different time of the year since most of them are seasonally breeders (*Gokhale, 1957; Polder, 1961*).

Teleost ovaries in early development consists of stroma and oogonia , the latter undergoing periodic mitosis in the most sexually mature adult (*Franchi et al.,1962*). Mitotic division of the oogonia in cyclic breeder teleost are characteristic of immediate post spawning period. Many tropical species breed continuously in a series of short cycles and undergoing periodic waves of oogonial mitosis. (*Hickling, 1936*) The cyclical nature of oogonial proliferation was inhibited in hypophysectomized fishes (*Hour, 1969; Donaldson, 1973; De Vlaming, 1974 and Tokarz, 1978*).

The Catfish have one pair of ovaries, which are situated, in the dorsal region of the body cavity. They are sac-like structure consisting of a wall with lamellae penetrating the central lumen. The lamellae contain oogonia and oocytes in the follicles at various stages of development (*Richter and Van Den Hurk, 1982; Van Den Hurk and Peute, 1985*).

---

**Periodicity of ovarian development: -**

*Bruton (1979)* studied the annual reproductive cycle in the African catfish, which can be divided into three periods, i.e. the breeding period, the resting period and a period of full gametogenesis.

During the breeding period (from May until August), the two ovaries are in postvitellogenic or in post-ovulatory stage. They show a strong  $3\beta$ -hydroxy steroid dehydrogenase ( $3\beta$ -HSD) activity in the special thecal cells and some interstitial cells. This activity is absent in the granulosa cells of the follicles. Postovulatory follicles next to previtellogenic and vitellogenic follicles are present in the ovulated ovaries. Fish in the postovulation stage were sporadically found, indicating that ovulation and spawning may take place several times during the breeding period. After ovulation the ovary return to the postvitellogenic stage. There is a continuous decrease in GSI, which indicate that, after ovulation, vitellogenesis is limited and does not lead to a restoration of the original number of postvitellogenic follicles.

The resting period (from August to March) comprises the stages of atresia and previtellogenesis. During this period the GSI is very low. Atresia mainly occurs in August, September and

October. It is characterized by regression of many follicles. These atretic follicles don't show any 3 $\beta$ -HSD activity. In the remaining healthy follicles the 3 $\beta$ -HSD activity is also absent or restricted to some special thecal cells and in the interstitial cells of the ovary. At the stage of previtellogenesis most atretic follicles disappear, and numerous previtellogenic and some endogenous vitellogenic follicles are present in the ovaries.

The period of full gametogenesis (begins in March and ends in May) is characterized by an enormous increase in GSI due to a strong vitellogenic activity in the ovaries. It comprises two stages, i.e. endogenous and exogenous vitellogenesis. The former differs from the previtellogenic ovary by the presence of numerous endogenous vitellogenic follicles (400-500  $\mu$ m in diameter) which show a weak 3 $\beta$ -HSD activity in their granulosa cells. The stage of exogenous vitellogenesis stands out by the presence of large exogenous vitellogenic follicles (up to 1000  $\mu$ m in diameter). These show, a weak to moderate 3  $\beta$ -HSD activity in their granulosa cells and a moderate to strong activity in the special thecal cells. Also, in some interstitial cells a moderate to strong 3 $\beta$ -HSD activity can be found in this stage (*Van Oordt et al., 1987*).

---

**Folliculogenesis :-**

Teleost ovarian follicles, like those of other vertebrates, consists of an oocyte, surrounded by zona pellucida, follicular epithelium (the granulosa), a basement membrane and one, or two thecal layers, bounded by peritoneal epithelium.

**Granulosa: -**

The granulosa is usually a single layer of cells (*Flügel, 1976 a;b; Nicholls & Maple, 1972; Busson-Mabillot, 1973; Guraya, et al., 1975; Dodd, 1977*). Cell height was changed during the cycle and development and the intercellular spaces develop (*Flügel, 1976a*) These changes may play an important role in teleost vitellogenesis (*Anderson, 1967*). The granulosa cells acquire a full complement of secretory organelles indicative of protein synthesis. Some of granulosa secretion help in the zona pellucida formation (*Wourms, 1976; Wourms & Sheldon, 1976*) and some of these secretion including phospholipids, are transported from the granulosa to the oocyte (*Guraya, 1965*) . Cytoplasmic processes from granulosa cells penetrate the zona pellucida (*Flügel, 1976a; Nicholls and Maple, 1972; Busson-Mabillot, 1973*). These interdigitate with microvilli from the oocyte and may come into close contact with the oocyte membrane (*Anderson, 1967*).

**Zona pellucida :-**

In the early stage of follicular growth , the oocyte lies in close contact with the inner surfaces of granulosa cells, through a space developed between them into which microvilli project from the oocyte surface and the zona pellucida is formed. In oviparous teleosts, the zona pellucida usually consists of three distinct layers, differing in structure, into which villi from both the oocyte and the granulosa cells project to form zona radiata (*Jollie & Jollie, 1964 a;b; Hurley & Fisher, 1966*).

*Busson-Mabillot (1973)* has shown that the three layers in *Cichlasoma Nigrofasciatum* change markedly in histochemistry and appearance during follicular development.

**Theca: -**

The outer margins of the granulosa cells are in contact with a rich capillary plexus supported by a basal lamina of variable thickness and contain collagen fibers (*Anderson, 1967, Guraya, 1978*). The theca consists of a layer of flattened fibroblasts-like cells containing secretory organelles. Enzyme histochemistry in some species, has shown that, the theca cells contain enzymes associated with steroidogenesis (*Anderson, 1967*).



---

*Bara (1965)* had demonstrated the presence of 3 $\beta$ -HSD and glucose -6-phosphate dehydrogenase in the thecal cells of Mackerel.

Steroid dehydrogenases have also been demonstrated in granulosa cells (*Lambert, 1966; 1970*).

#### Vitellogenesis :-

Studies on a variety of non-mammalian vertebrates, specially on the female South African clawed toad (*Xenopus laevis*), have shown that, vitellogenin (a lipoglyco phosphoprotein) is secreted by liver under estrogen stimulation. Under the influence of gonadotrophins, it is selectively taken by the growing oocytes and converted into yolk protein (*Wallace, 1978*). In teleosts, there is fairly good evidence that some of the yolk components may be synthesized within the oocyte itself, rather than originating exclusively from liver (*Korfsmeier, 1966; Norrevang, 1968 and Upodhyay et al., 1978*). Furthermore, the yolk proteins, lipovitellin and phosvitin isolated from teleosts are generally a typical, they are frequently heterogenous both in respect to their mollecular and protein-bound phosphorous content, and are generally soluble in solutions of low ionic strength (*Mono & Lipmann, 1966; Jared and Wallace, 1968; Hori et al., 1979*).

---

There seems little doubt that vitellogenin synthesis in the liver and secretion into the blood is induced by estrogens in a variety of teleost species (*Plack et al., 1971; Lemenn & Lamy, 1977; Elliott et al., 1979*).

Vitellogenesis is thought not to occur normally in male teleosts, it can be induced by estrogens (*Emmersen et al., 1979; Hori et al., 1979*) and massive dose of androgen (*Hori et al., 1979*). This induction of vitellogenin synthesis by androgen could be due to aromatisation of androgen into estrogen, which could then exert its usual physiological action. The elevated estrogen level necessary to induce vitellogenesis was presumed to be caused by a preceding rise in gonadotropin secretion from the pituitary gland. Even though vitellogenesis has been demonstrated to be under pituitary control in some species (*Barr, 1963*). Beside the gonadotropin stimulating vitellogenin synthesis, it was also thought to stimulate the ovary to incorporate this vitellogenin, the yolk precursor into the oocytes, where it is transformed into yolk platelet protein (*Idler and Ng, 1979*).

**Periodicity of the pituitary gonadotropic development: -**

*Van Oordt et al. (1987)* found that, changes in the pituitary (GTH) content follow an annual cycle, like reproductive cycle, can be divided into three periods, i.e. breeding period, resting period

---

and period of full gametogenesis. In male, the pituitary GTH content reaches the peak values at the beginning of the breeding period (in May) preceding the peak value in females by two months. The pituitary GTH content in males decrease during the breeding period and continues to do so till a minimum level is reached shortly after the beginning of the resting period (in October). In females the decrease in gonadotropin does not start before the end of breeding period and lead to a minimum gonadotropin (GTH) content in the pituitary (in November). Before the end of resting period (in February) and during the period of full gametogenesis an increased amount of GTH is stored in the pituitary. The ultrastructures of the gonadotropic cells follow the seasonal variation in pituitary GTH content (*Van Oordt et al., 1987*).

#### **Natural reproduction of the fish: -**

Three basic steps must be done for successful reproduction (maturation, ovulation and spawning).

#### **Maturation of the eggs :-**

According to (*Piper et al., 1989*), it is a complex process including several changes :-

---

1) **Vitellogenesis:** - It is an important step, in which yolk protein are produced in the liver and transported to the ovary and stored in the eggs and used as a source of nutrition for developing the embryos.

2) **Germinal vesicle migration and breakdown (GVBD):** - Before the germinal vesicle or nucleus migrate, it was located in the center of egg on arrested stage of development. At this stage the egg is physiologically and genetically incapable of being fertilized. When the conditions are favorable for final maturation, nuclear development resumes and germinal vesicle rupture release the chromosomes into the cells. After the egg was matured, a substance called prostaglandin stimulates the ovulation and cause rupture of the follicular cells (that hold the eggs). The eggs are released in the body cavity or in the ovarian lumen and then to the outside.

**Induced reproduction in fish:** -

Among the most significant advancement in the field of aquaculture during the recent years is the development of techniques to induce reproduction in fish. This technique allowed to produce breeds and raise species that do not naturally reproduce in captivity and also to manipulate the timing of reproduction. Some breeds will not reproduce in captivity due to environmental or culture conditions that are different from those found in nature such as, water temperature. Those conditions may cause stress or may not provide the conditions needed to complete

---

the reproductive process (*Dupree, 1984*). The induced reproduction has some advantages as: -

- 1) It improves the efficiency by getting fish to spawn on predetermined date.
- 2) Obtain fish outside of normal spawning season to lengthen the time for grow out.
- 3) Maximal survival by fertilizing and incubating eggs under hatchery conditions.

The induced reproduction can be made by two methods (*Staff, 1983*):-

- 1) Provide an environment similar to that in which spawning occur naturally.
- 2) Injecting the fish with one or more naturally occurring reproductive hormones or their synthetic analogues.

In many cases, fish kept under captive condition fail to proceed through their normal reproductive cycle. It has been assumed that, culture conditions do not provide an environment conducive to completing maturation of the gonad and spawning. In other cases, changing the culture environment has proven sufficient alteration for fish to resume their normal reproductive activities. In other cases, intervention via hormonal therapy is required at some point along hypothalamic-pituitary

gonadal axis which control reproductive activities in teleost fishes (*Lam, 1982; Donaldson and Hunter, 1983*).

Hormonal intervention is presently the most effective method for inducing final maturation and spawning.

**Induction of ovulation and spawning by hypophysation (pituitary gland homogenate ):-**

Pituitary gland homogenate from salmon, mullet and carp (*Tang, 1964; Yashouv et al., 1969; Shehadeh and Ellis, 1970*) were used.

The utilization of the carp pituitary homogenate (CPH) as priming dose for induction of maturation and spawning in mullet, followed by luteinizing hormone-releasing hormone analogue (LHRH-A) as a resolving dose, result in high fertilization rate.

Spawning time and change in egg morphology very similar to those obtained when using human chorionic gonadotropin (HCG) or salmon gonadotropin G100 (SG.G100) (*Kuo et al., 1973; Shehadeh et al., 1973*).

The researches at the Oceanic- Institute of Hawaii recently replaced the HCG, which was used as a priming dose for induction of maturation and spawning in mullet, with CPH to decrease the cost of spawning. In the past, the mullet was spawned within 24 h after a priming dose of 20 I.U. of HCG /gm body weight and a resolving dose of 40 I.U. of HCG /gm body weight (*Kuo et al.1973*). The CPH can be injected

also, with a steroid such as deoxycorticosterone (DOC) for induction of maturation and spawning (*Kuo, 1982*).

*Lee et al. (1988)* reported that the most reliable method for maturation and spawning of mullet is an acute hormonal therapy combining either CPH with HCG or CPH with LHRH-a and in both cases CPH, given as a priming dose.

**Induction of ovulation and spawning by human chorionic gonadotropin (HCG):-**

*Clemens and Sneed (1962)* recommended that, the hormone dosage used to induce ovulation in a given species should be in excess of the minimal dose determined experimentally. This precaution can be useful to avoid the failure due to possible difference of sensitivity between brooder of different origin or ages.

*Kuo et al. (1973)* concluded that mullet will spawn within 24h, after a priming injection of 20 i.u of HCG/gm body weight, and a resolving injection of 400 i.u of HCG/gm body wt. This method is simple and convenient.

However, researchers at Oceanic Institute of Hawaii recently replaced the priming dose of HCG with CPH . The fish was induced to spawn using 40mg CPH and 4000 i.u. HCG.

The milkfish was induced to spawn using pituitary extract of salmon or carp plus HCG (*Vanstone et al., 1977; Juario et al., 1979; Kuo et al., 1979; Lio et al., 1979*).

Human chorionic gonadotropin has been used to bring the final maturation of the ova in some fish species (*Tseng and Hsiao, 1979; Lin, 1984*).

*Mollah and Tan (1983)* observed very little variation in the latency response of *Clarias Macrocephalus* despite the different dosage of HCG used (1-5 i.u./gm body wt.).

The HCG can be used successfully to induce spawning in several fish species but, this mammalian high molecular weight substance could provoke an immune reaction in some species, making it inefficient after repeated use. Such reaction has been observed in *Sparus aurata*, which for this reason can be used only during a single reproductive season (*Guiral, 1983*).

*Legendre (1986)* studied the effect of HCG induced breeding in catfish (*Heterobranchus longifilis*) and found that, a single injection of 1-2.5 i.u. HCG /g.body wt. Induced ovulation in 100% treated females. A lower dose lead to high variability in individual response. The minimal dose of HCG determined for *H. longifilis* is lower than those determined for other Clariids, 2.0 i.u./gm body wt. In *C. Macrocephalus* (*Mollah and Tan, 1983*) and 2.5 i.u./gm body wt., in *C. garipinus* (*Eding et al., 1982*).



*Legendre (1986)* found that, the latent period in *H. longifilis* was influenced much more by temperature than by injected dose of HCG. However, the latency in other fish species was dependent both on temperature and hormone dosage (*Clemens and Sneed, 1962; Harvey and Hoar, 1980*).

HCG also was used alone or in combination with fish gonadotropin for spawning milkfish (*Lam, 1984; Kuo, 1985*). However, most fishes required at least two injections of HCG and a hand stripping of ovulated eggs. Milkfish were invariably stripped after one to three injections of HCG or HCG combined with various pituitary preparations.

*Marte et al. (1988)* reported that a single injection of 1000 i.u. HCG/Kg body wt was effective as 10 ug of gonadotropin-releasing hormone analogue (Gn RH-a)/Kg b.w. or 100 ug of GnRH-a /fish for spawning milkfish.

#### **Induction of ovulation and spawning using luteinizing hormone-releasing hormone analogue (LHRH-a):-**

The luteinizing hormone-releasing hormone (LHRH) and its synthetic analogue have been used to induce ovulation in many fish species (*Breton and Weil, 1973; Hirose and Ishida, 1974; Lam et al, 1975*).

---

*Donaldson et al., (1981)* reported that, both LHRH and its analogue are capable of inducing ovulation in Coho salmon when used in combination with SG.G100 as a primer injection.

*Kuo (1982)* observed that, the GnRH was required as a priming dose injection in many fish species to stimulate oocyte development from tertiary yolk globule stage to sub peripheral germinal vesicle stage.

LHRH-a was used to induce final maturation and spawning in teleost fish (*Lam, 1982; Donaldson and Hunter, 1983*).

*Lee et al (1986 b) and Marte et al. (1987)* studied the induction of spawning in milkfish by a single application of LHRH-a by pellets implants or injection. They found that , when LHRH-a implanted in fishes in the early phase of spawning season, the fish possessed large eggs spawn. The spawning of hydrated eggs was regulated by slow release of LHRH-a from the pellet-implant. They also demonstrated that the spawning achieved when LHRH-a was given as a surge injection irrespective to the total dosage given to the individual by injection or in the pellet..

LHRH-a, when used alone or in combination with CPH, is capable of inducing final stages of maturation and spawning in the Grey mullet (*Lee et al., 1987*).

The reproductive response of the individual milkfish to the GnRH-a may be variable due to several factors, i.e. initial oocyte

diameter of the experimental fish (varied widely and may reflect differences in degree of completion of vitellogenin), the age and reproductive history of the fish, and the amount of the stress during selection of maturing spawner may also contributed to the variability of response (Marte *et al.*,1987).

Marte *et al.* (1988) studied the effect of salmon and mammalian gonadotropin on milkfish and he found that, GnRH-a administered in pellet implant was less effective than injection, which was in contrast with earlier results which showed similar effectiveness of pellet implantation and injection. One reason for the poor response of GnRH-a (Salmon GnRH-a) implanted fish may be due to, the mean diameter of the oocyte (0.65 mm) where, they indicate that milkfish oocyte with diameter below 0.63 mm have not complete vitellogenesis and will be unresponsive to GnRH-a. The same authors also found variation in response of milkfish having oocyte diameter between 0.63-0.69mm indicating that, maturation of the oocytes following hormone induction may take a long time.

Recently, Slater *et al.* (1994) reported that, the GnRH-a accelerate the final maturation ,ovulation and spermiation of Sockeye-Salmon.

#### **The role of some hormones in inducing oocyte maturation in vitro.**

Hormones, either as crude preparation or in a purified form, have long been used to promote growth and reproductivity in economic fish

culture (*Jalabert, 1976 and Yamazaki, 1976*). The role of these hormones in growth, maturation and ovulation is essential for the development of effective methods of fish cultivation. In this respect, in vitro, oocyte maturation system was developed in the case of *Salmo gairdneri* (*Jalabert et al., 1974*), *Cyprinus carpio* (*Epler et al., 1986*) and *Esox lucius* (*Jalabert and Breton, 1973*).

#### **Effect of combination of HCG and CPH:-**

*Epler et al. (1986)* studied the joint action of CPH and HCG in carp oocyte maturation and ovulation in vitro and they found that, the HCG (a dosage of 100 i.u./ml of media) does not cause an increase in the percentage of maturation of oocytes. But, when HCG together with CPH at ratios of 6:4 & 5:5 & 4:6 (dosage of 60,50,40 i.u./ml of HCG and 40,50,60ug/ml of CPH.) gave a higher percentage of mature oocytes than did CPH (100ug/ml) alone. This observation might be due to increasing number or affinity of gonadotropin-hormones (GTH) receptors in the follicular cells of the oocytes or due to acceleration of steroid biosynthesis (*Colombo and Colombo, 1977*). It is also possible that HCG may affect the production of a specific gonadal steroid, which directly affect oocyte maturation, but the amount of this steroid is insufficient to initiate oocyte maturation, the effect being visible only in the presence of carp pituitary gonadotropin (CPH). This possibly indicates a synergistic

effect of pituitary gonadotropin with steroid, which was suggested, by *Jalabert (1976)* in the Rainbow trout and by *Epler (1981c)* in carp.

However, in vitro incubation of *Oreochromis niloticus* oocyte with CPH (50 ug/ml of chemically defined medium) followed by HCG (100i.u./ml) after 6hr was ineffective in increasing the percentage of mature oocytes over the control incubation containing CPH only (*Ahmed et al.,1987*).

It has been hypothesized in many teleosts that, the pituitary gonadotropin induce final maturation indirectly by stimulating the synthesis of maturational steroid in the ovarian follicles (*Hirose, 1976; Jalabert, 1976; Sundararaj and Goswami, 1977& Iwamatsu, 1978*).

#### **Effect of steroid hormones on in vitro maturation of the oocytes:-**

*Pankhurst et al.(1986)* found that , the level of  $17\alpha,20\beta$ -P increased with GVBD in Walleye fish, and concluded that  $17\alpha,20\beta$ -P may be the maturation induced steroid in this species. The level of  $17\alpha,20\beta$ -P in plasma of spawning Walleye, however, were very low relative to those reported in some Salmonid species which suggest that , another steroid besides  $17\alpha,20\beta$ -P may induce maturation in Walleye or Walleye oocytes are more sensitive to  $17\alpha,20\beta$ -P than Salmonid oocytes. This second hypothesis was supported by the studies of *Goetz and Theofan (1979)*, that the oocyte of Yellow perch are much sensitive to

maturation inducing effect of  $17\alpha,20\beta$ -P than Salmonid oocyte in vitro while in other fish species in vitro studies have shown that, of all steroid so far investigated  $17\alpha$ -hydroxy,  $20\beta$ -dihydroxy progesterone ( $17\alpha,20\beta$ -P) is generally the most potent in inducing oocyte maturation (but not ovulation) in Brook trout, *Salvelinus fontinalis* (*Duffy and Goetz,1980*), Rainbow trout, *Salmo gairdneri*, and Pike, *Esox lucius* (*Fostier et al.,1973; Jalabert,1976*) Yellow perch, *Perca flavescens* and carp (*Epler,1981a;b*), ayu, *Plecoglossus altivelis*, Amago salmon, *Oncorhynchus rhodurus* and goldfish (*Nagahama et al.,1983*)

In addition, *Barry et al. (1995)* studied the effect of some steroid on in vitro maturation of the Walleye oocytes and they found that, the two most potent steroid for inducing germinal vesicle breakdown (GVBD) were  $17\alpha,20\beta$ -dihydroxy-4-pregnen-3-one, and  $17\alpha,20\beta,21$ -trihydroxy-4-pregnen-3-one at the concentration of  $1\text{ ng ml}^{-1}$ .

It was found that, in some fish species oocyte maturation, but not ovulation has been induced by 11-deoxy corticosterone (*Richter and Van Den Hurk,1982*). Also, 11-deoxy corticosterone has been shown to be fairly effective in inducing oocyte maturation in vitro in number of species as Zebra fish, *Brachydanio rerio* (*Van Ree et al.,1977*), Indian catfish, *Heteropneustes fossilis* (*Goswami and Sundararaj,1971; 1974*), brook-trout and Yellow perch (*Goetz and Theofan, 1979*), goldfish and pike (*Jalabert et al.,1973*). In the last four species, ( $17\alpha,20\beta$ -P) has been

shown to be more potent. The production of this steroid requires the presence of 21-hydroxylase. This enzyme has been identified in ovaries of certain marine teleosts (*Colombo et al., 1978*), but not on ovary of Zebra fish (*Lambert and Van Den Hurk, 1982*).

In addition, *Barry et al. (1995)* when used 11-deoxycortisol and 11-deoxy corticosterone on the in vitro maturation of Walleye oocytes, they found that, these two steroids when used at higher dose ( $10 \text{ ng ml}^{-1}$ ) stimulated GVBD.

*Billard et al. (1982)* studied the effect of some steroids on vitellogenesis and they reported a significant inhibition of vitellogenesis in rainbow trout fed an  $17\alpha$ -methyltestosterone-enriched diet for 6 months. They suggested that chronic treatment with  $17\alpha$ -methyltestosterone may exert its inhibitory effect indirectly through a negative feed back on GTH secretion or directly on the ovaries.

In addition, *Lee et al. (1986b)* found that, female Milkfish failed to mature following treatment with liquid or crystalline  $17\alpha$ -methyltestosterone. Although androgen have been postulated to have a role in vitellogenesis in fish (*Fosteir et al., 1983*).

The use of androgen MT ( $17\alpha$ -methyltestosterone) in combination with LHRHa has proven effective in accelerating ovarian maturation in several fish species (*Crim et al., 1983*). Also, three monthly implantation

---

of MT together with LHRHa induce a high incidence of sexually mature Milkfish (*Lee et al., 1988*).

Earlier studies with sexually immature juvenile rainbow trout indicated that aromatizable androgens induce a rapid and prolonged accumulation of pituitary gonadotropin hormone (*Crim and Evans, 1979; Crim et al., 1981*).

*Garcia (1990)* studied the effect of pelleted  $17\alpha$ -methyltestosterone on sexual maturation and spawning of Sea bass and found that, regular implantation of pelleted MT is effective in stimulating gonadal development to significantly advance spawning several months before the peak breeding period.



---

**MATERIALS AND METHODS****Fishes**

140 adult females and 50 male African catfish (*Clarias lazera*), with average body weight 350 gm were purchased alive and in a good condition from fish markets of Edfina-Behera, during the breeding season (April-August), and transported to the laboratory of Animal Physiology Department, Faculty of Veterinary Medicine, Edfina, Alexandria University. They were kept in glass aquaria (100X30 X60 cm) supplied with aerated water for one week for acclimatization before the start of the experiment. The water in the tanks was thermostatically kept at  $27 \pm 0.5$  °C using submersible heaters.

Food was not provided during this period. The fish were kept in artificial lighting 9hrs per day (from 8:00 to 17:00 h).

**Clearing solution: -**

It is a solution used for clearing the eggs, to be easily examined. It is composed of equal parts of 10% formalin, 60% ethyl alcohol, 30% glacial acetic acid (*Haas, 1982*).

**Earle's solution:-**

It was used as a media for incubation of the eggs. It is composed of: -

1) Solution "A" which is a mixture of :-

---

- Sodium chloride	6.8 gm
- Potassium chloride	0.4 gm
-Sodium dihydrogen phosphate	0.2 gm
-Magnesium sulphate	0.4 gm
-Phenol red	0.017 gm
-Dextrose	1.0 gm

Add distilled water to 800 ml

2) Solution "B" which consists of :-

- Calcium chloride 0.2 gm
- Add distilled water to ..... 100 ml

Earle's solution was prepared by adding solution "A" to solution "B" and then distilled water was completed to 1000 ml. The pH of the solution was adjusted at 7.7-8.0 using pH paper, followed by sterilization in the autoclave for 10 minutes (*Cruickshank et al., 1973*).

### Experiment 1

#### Effect of some hormones on the in vitro maturation of Catfish

##### (Clarias lazera) oocytes :-

##### Egg collection: -

After the period of acclimatization, 90 female catfish were weighed then the abdomen was dissected to obtain the ovaries. The ovaries were weighed to the nearest gm. From each fish two portions

of ovaries were obtained, one portion was immersed in the clearing solution to determine the egg diameter and the degree of egg maturation using a stereomicroscope supplied with a micrometer. The other ovarian portion was used for hormonal treatment.

The degree of oocyte maturation was determined according to the germinal vesicle breakdown parameter (*Epler, 1981a*) and according to the oocyte diameter in Catfish (*Lehri, 1968*), Sea bass (*Garcia, 1990*).

### **Procedure of studying the effect of some hormones on egg maturation:**

#### **1- Treating the eggs with enzyme:-**

Fresh ovarian fragments obtained from a Catfish was incubated with alpha chymotrypsin enzyme (Laboratories Leurquine Medulanium) to disperse the eggs. Ovarian fragments were placed in a Petri dish containing alpha chymotrypsin enzyme (5 mg/100ml distilled water for treating  $180 \pm 20$  oocytes for 5 minutes at room temperature to remove the sticky layer on the eggs. Eggs were dispersed loose after this treatment.

#### **2- Egg incubation :-**

- a) Incubation in Earle's solution containing human chorionic gonadotropin (HCG) (Pregnyle, Organon) :-

Dispersed eggs were incubated in a Petri dish containing HCG (100 I.U/ml Earle's solution) for 6 hrs at room temperature ( $25 \pm 1.0^{\circ}\text{C}$ ) without special gas atmosphere (*Ahmed et al, 1987*). Each Petri dish containing 30 ml Earle's solution and about  $180 \pm 20$  oocytes.

b) Addition of different hormones :-

After 6 hrs of incubation in Earle's solution containing HCG, the eggs were distributed to 9 groups. Each group was incubated for 42hrs with one of the following hormones:-

<u>Hormone No.</u>	<u>Chemical formula</u>
1-	5 $\alpha$ -androstan-17 $\beta$ -ol-3-one (Sigma)
2-	5 $\beta$ - androstane -3,17-dione (Sigma)
3-	Dehydro isoandrosterone (Sigma)
4-	Androstenedione M.W.286.4 (Sigma)
5-	Testosterone M.W. 288.41 (Sigma)
6-	$\Delta^5$ - pregnen-3 $\beta$ -ol-20-one (Sigma)
7-	4-pregnen-20 $\beta$ -Ol-3-one (Steraloid's Incorporation).
8-	5 $\alpha$ -pregnane-3 $\beta$ ,20 $\alpha$ -diol (Sigma)
9	5-hydroxy-tryptamine (Serotonin) (Sigma)

Three concentrations of each hormone were used (1,2 and 3  $\mu\text{g/ml}$  Earle's solution). Each dish contains 30ml Earle's solution and the number of eggs was about 200 eggs in each dish. After incubation with different hormones, the oocytes were cleared in clearing solution to determine egg diameter and degree of oocyte maturation using stereomicroscope supplied with micrometer lens.

## **Experiment 2**

### **Artificial propagation of Catfish (*Clarias lazera*):-**

#### **Preparation of carp pituitary homogenate (CPH) :-**

The carp pituitaries used were kindly provided by Abasa fish hatchery. They were homogenized in 0.9 %NaCl (3.5-4mg carp pituitary in one ml saline). The homogenate was then centrifuged for 15 minutes at 3000 rpm. The supernatant fluid was then used for hypophysation of catfish.

#### **Injection of the fish:-**

50 females and 50 male mature catfish were injected by CPh (0.5ml/fish) in the dorsal musculature below the dorsal fin (*Van Der Wall, 1985*). The injection was made in the evening between 17.00hr and 17.30 hr. The injected fish were kept separately in aquarium till the end of the experiment.

**Checking for ovulation: -**

After a latency time of 18-21 hrs, the fishes were examined for ovulation by hand stripping. The abdomen was gently squeezed towards the ovipore. Fish that yielded copious stream of green brown eggs were rated as ovulated fish (*Manickam and Joy, 1989*).

**Artificial fertilization:-**

Immediately before stripping the female, male spawners were sacrificed and the testes were removed and macerated in sodium chloride 0.9% (dilution rate  $10^{-1}$ ) as soon as possible (*legendre, 1986*). The sperm suspension was checked under the microscope for detecting sperm motility. The sperm suspensions were sprinkled over the egg mass evenly and clean water was added. The gametes were allowed to mix by gentle moving for 5 minutes.

**Incubation of the fertilized eggs: -**

The fertilized eggs were transferred into Zug jars (Fig. 1) at a rate of about 200 eggs/Jar. The eggs were incubated at room temperature ( $25\pm 1.0^{\circ}\text{C}$ ) in aerated water for 48 hrs. (*Manickam and Joy, 1989*).

After 10hrs of incubation, the eggs in the Zug-jars were treated with alpha chymotrypsin (5mg/100ml dist. water) for 5 minutes to disperse the egg mass. The enzyme solution was then removed by washing the eggs with clean water.

---

Microscopic examination was done after 24 hrs to check the unfertilized or dead (white) eggs, which were counted and removed immediately to prevent fungal infection. The number of hatched eggs was recorded after 24 hrs from incubation. The number of normal fry and deformed fry was also recorded after 48 hrs. The deformed fry were recognized by their curved tail and shortened body (*Manickam and Joy, 1989*).

**Statistics:**

The statistical analysis was done to determine the effect of different hormones on the egg diameter according to *SAS (1987)*.

Fig ( 1 )

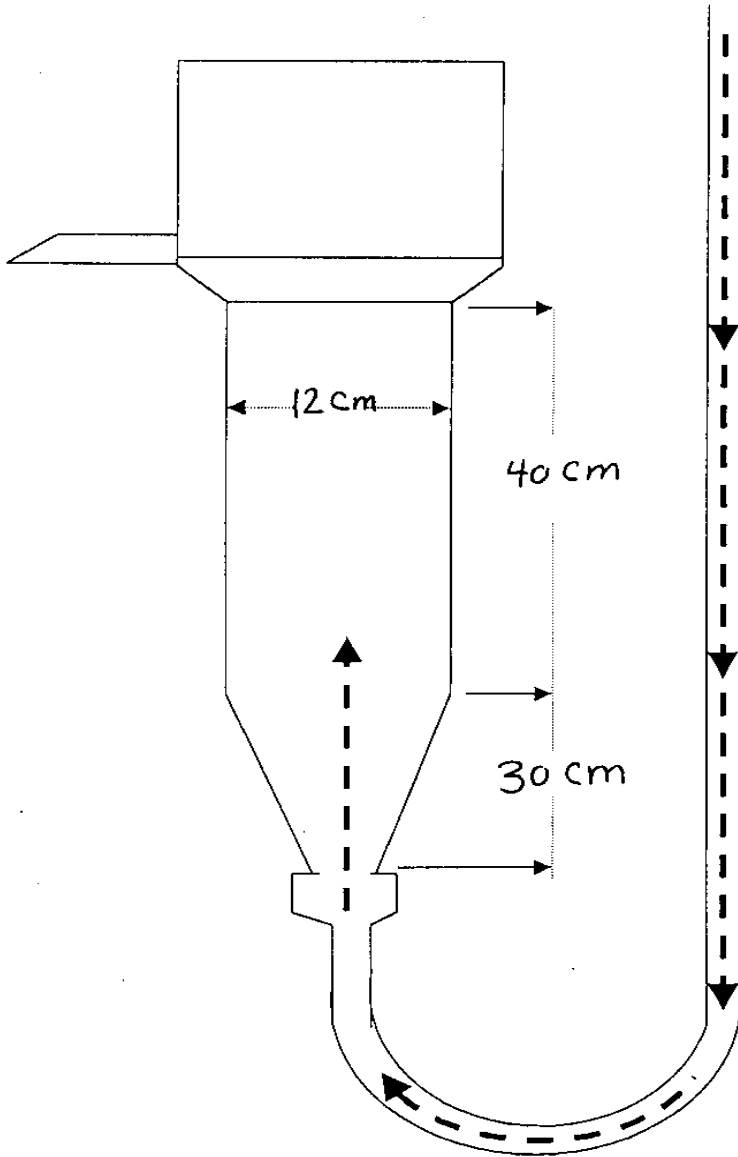

Zug Jar



---

## RESULTS

### Experiment 1.

#### Hormonal effect on the in vitro maturation of catfish (*Clarias lazera*) oocytes.

In vitro maturation of Catfish oocytes , Table (1) and Fig.. (2) indicated that, the incubation of Catfish oocytes in Earle's solution containing  $\Delta^5$ -pregnen-3 $\beta$ -ol-20-one (3 $\mu$ g/ml), 5 $\beta$ -androstane-3,17-dione (1 $\mu$ g/ml) or 4-pregnen-20 $\beta$ -ol-3-one (2 $\mu$ g/ml) resulted in significant increase in oocyte diameter (P <0.01).

A non -significant increase in the egg diameter occurred on the incubation of oocytes in Earle's media containing either  $\Delta^5$ -pregnen-3 $\beta$ -ol-20 -one (2 $\mu$ g/ml), testosterone (3 $\mu$ g/ml), 5 $\alpha$ -androstan-17 $\beta$ -ol-3-one (2 $\mu$ g/ml) or 5  $\alpha$ -pregnane-3 $\beta$ ,20 $\alpha$ -diol (1 $\mu$ g/ml).

Table (1) and Fig.. (2) reveals also that, HCG (100 I.U./ml),  $\Delta^5$ -pregnen-3 $\beta$ -Ol-20-one (1 $\mu$ g/ml), androstenedione (1 ,2 or 3  $\mu$ g/ml), 5 $\beta$ -androstane-3, 17-dione (2 or 3  $\mu$ g/ml), 4-pregnen-20 $\beta$ -ol-3- one (1 or 3 $\mu$ g/ml), testosterone (1 or 2  $\mu$ g/ml), dehydroiso-androsterone (1 , 2 or 3  $\mu$ g /ml), serotonin (1,2 or 3  $\mu$ g /ml), 5  $\alpha$ -androstan-17 $\beta$ -ol-3-one (1 or 3  $\mu$ g /ml) and 5  $\alpha$ - pregnane-3 $\beta$ ,20 $\alpha$ -diol (2 or 3  $\mu$ g /ml) had no effect on oocyte diameter as compared to those of control oocytes.

Table (1): Effect of different hormones concentrations on the egg diameter ( $\mu$ ) of African catfish (*Clarias lazera*).

Treatment	Egg diameter (microns)
Control	699.69 $\pm$ 15.19
HCG (Human chorionic gonadotrophine) 100 Iu/ml	691.00 $\pm$ 14.36
$\Delta^2$ -pregnen-3 $\beta$ -ol-20 one 1 $\mu$ g/ml	670.17 $\pm$ 20.99
2 $\mu$ g/ml	705.78 $\pm$ 20.29
3 $\mu$ g/ml	829.68 $\pm$ 60.41*
Androstenedione 1 $\mu$ g/ml	647.55 $\pm$ 17.85
2 $\mu$ g/ml	622.47 $\pm$ 20.00
3 $\mu$ g/ml	679.39 $\pm$ 19.97
5 $\beta$ -androstane - 3, 17dione 1 $\mu$ g/ml	776.93 $\pm$ 16.57*
2 $\mu$ g/ml	672.94 $\pm$ 16.40
3 $\mu$ g/ml	665.54 $\pm$ 17.86
4-pregnen-20 $\beta$ -ol-3-one 1 $\mu$ g/ml	634.34 $\pm$ 22.80
2 $\mu$ g/ml	771.40 $\pm$ 18.97*
3 $\mu$ g/ml	626.15 $\pm$ 21.11
Testosterone 1 $\mu$ g/ml	598.70 $\pm$ 18.80
2 $\mu$ g/ml	690.62 $\pm$ 18.21
3 $\mu$ g/ml	706.88 $\pm$ 16.08
Dehydroisoandrosterone 1 $\mu$ g/ml	624.07 $\pm$ 19.13
2 $\mu$ g/ml	648.93 $\pm$ 15.65
3 $\mu$ g/ml	641.57 $\pm$ 19.51
5-hydroxy-tryptamine (Serotonin) 1 $\mu$ g/ml	694.84 $\pm$ 22.26
2 $\mu$ g/ml	674.75 $\pm$ 22.26
3 $\mu$ g/ml	642.67 $\pm$ 23.71
5 $\alpha$ -androstan -17 $\beta$ -ol-3-one 1 $\mu$ g/ml	641.60 $\pm$ 19.16
2 $\mu$ g/ml	703.40 $\pm$ 39.09
3 $\mu$ g/ml	662.27 $\pm$ 27.57
5 $\alpha$ -pregnane -3 $\beta$ , 20 $\alpha$ -diol 1 $\mu$ g/ml	702.57 $\pm$ 19.13
2 $\mu$ g/ml	662.40 $\pm$ 17.83
3 $\mu$ g/ml	642.67 $\pm$ 23.71

\* Values represent Mean  $\pm$  S.E

\* The diameter of 100 eggs were counted for each egg group after 48 hrs. incubation.

\* Means having letter (a) are significantly different from control level at ( $P < 0.01$ ).

\* A primary dose of HCG( 100 I.u/ml of incubation medium) was added to the incubation medium followed 6 hrs. Later by the addition of different hormone concentration.

\* Immature eggs were incubated with the hormones in Earle's solution at ( $25^{\circ}\text{C} \pm 1^{\circ}\text{C}$ ) for 48 hrs.

Fig. (2): Effect of different hormones concentrations on the egg diameter of African cat fish (*Clarias lazera*) measured by micron ( $\mu$ )

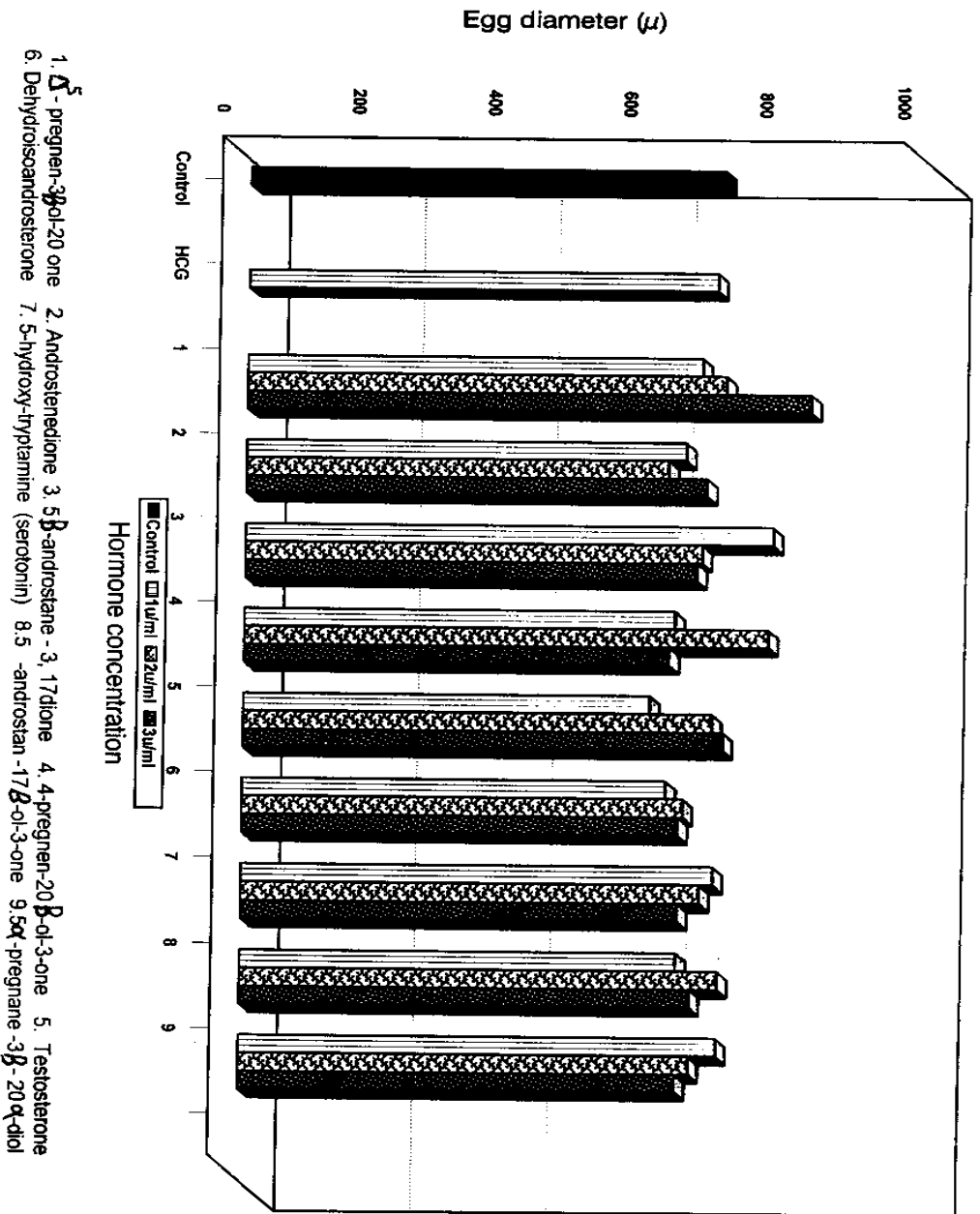

1.  $\Delta^5$ -pregnen- $3\beta$ -ol-20 one
2. Androstenedione
3.  $5\beta$ -androstane- $3,17$ dione
4. 4-pregnen- $20\beta$ -ol-3-one
5. Testosterone
6. Dehydroisandrosterone
7. 5-hydroxy-tryptamine (serotonin)
8. 5 $\alpha$ -androstane- $17\beta$ -ol-3-one
9.  $5\alpha$ -pregnane- $3\beta$ - $20\alpha$ -diol

Immature eggs were incubated with the hormone in Earle's solution at 25 C  $\pm$  1 C for 48 hrs.

## **Experiment 2 Artificial propagation of the catfish (*Clarias lazera*):-**

### **1- Response of female catfish to hypophysation :-**

All female catfish injected with carp pituitary homogenate (CPH) were ovulated. A copious stream of green brown eggs comes out from the ovipore of ovulated females upon gentle abdominal massage. Fig.. (4, 7, 8 ) show female genital organs of *Clarias lazera*.

### **2- Response of male catfish to hypophysation:-**

Fig. . (3, 5, 6 ) show the male reproductive organs of *Clarias lazera*. Intramuscular injection of CPH. in male Catfish during the breeding season induced ripening of testes in all injected males. The testes had white colour and filled with milt which readily flow from the testes upon its puncture.

Microscopic examination of fertilized eggs was shown in Fig. (11-16). After artificial fertilization, eggs developed into morula (Fig.13 ) after 10 hrs of incubation, egg hatching occurred 24 hrs after incubation. The hatching percentage was  $91.88 \pm 7.4\%$  . After 48 hrs from incubation the percentage of normal fry (Fig. 15) was  $87 \pm 3.1\%$  and that of deformed fry (Fig. 16 ) was  $12 \pm 1.4\%$  as indicated in Table (2).

**Table (2). Percentage of hatched eggs, dead eggs and normal fry and deformed fry after artificial fertilization.**

Hatching%	Dead eggs %	Normal fry%	Deformed fry %
91.88±7.4	7.9 ±1.9	87 ± 3.1	12 ±1.4

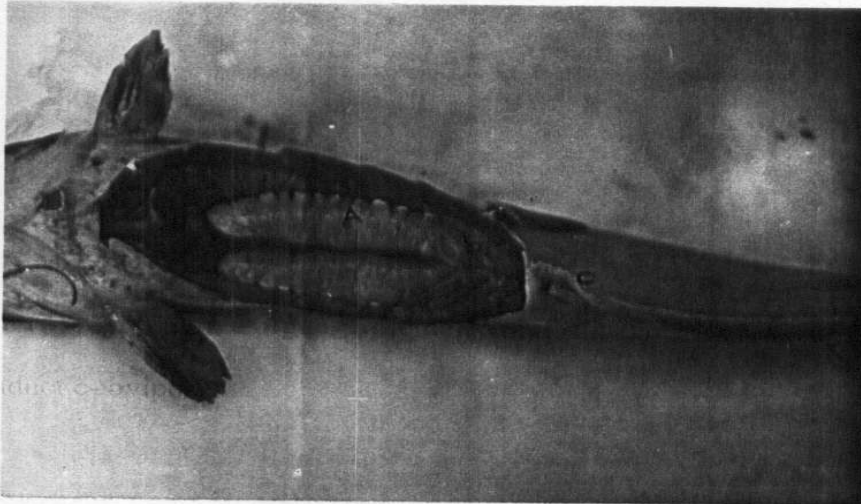

Fig. (3) Reproductive organs of male *Clarias lazera*: a-Testis b.Seminal vesicle c-Urogenital papilla.



Fig.. (4) reproductive organs of female *Clarias lazera*. a-Ovaries b-Oviduct c- ovipore.

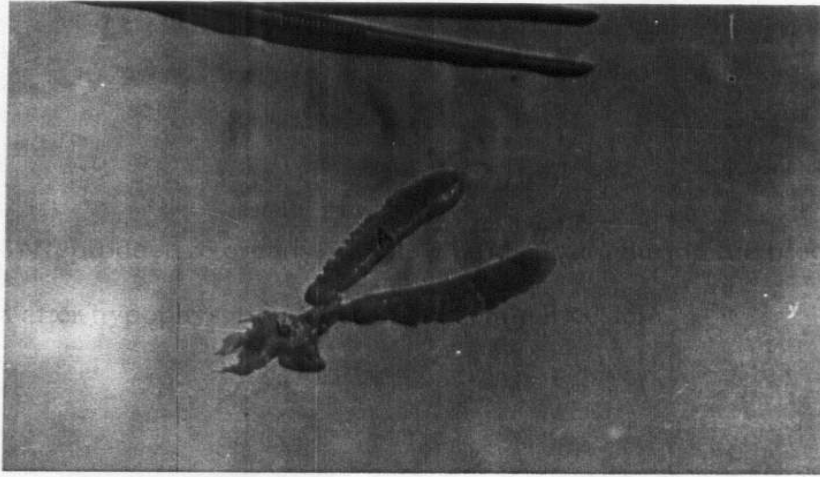

Fig. (5 ) Reproductive organs of male *Clarias lazera* during the breeding season before hypophysation. a-Testis b-seminal vesicle .



Fig. (6) Reproductive organs of male *Clarias lazera* during the breeding season after hypophysation. a-Testis b-seminal vesicle.

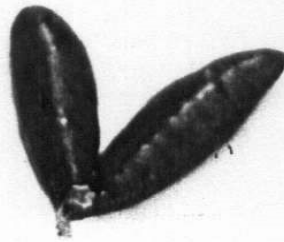

Fig.. (7 ) Reproductive organs of female *Clarias lazera* during breeding season before hypophysation. a- Ovaries b- oviduct.

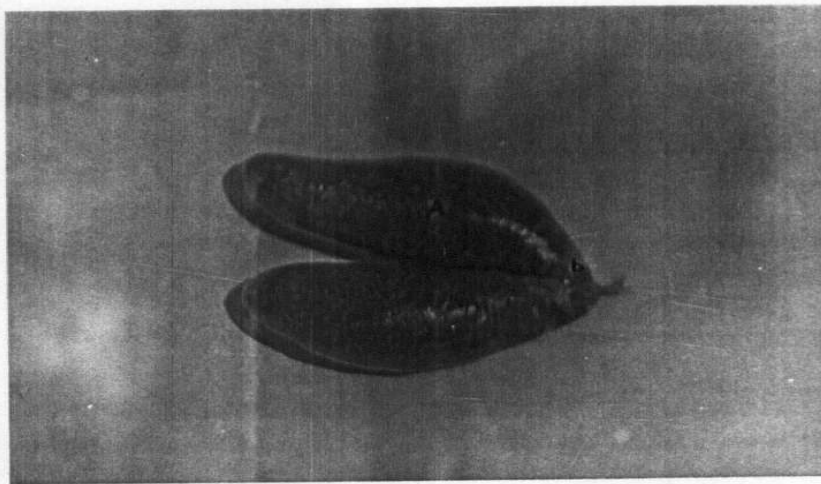

Fig.. (8) Reproductive organs of female *Clarias lazera* during breeding season after hypophysation. a- Ovaries b- oviduct.

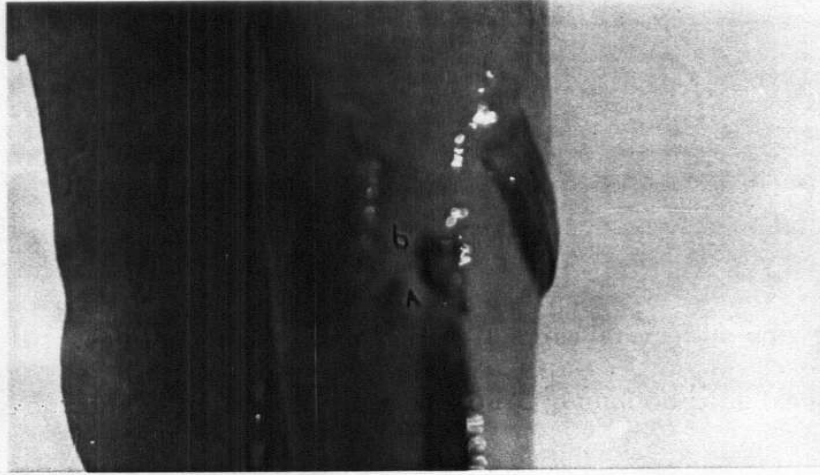

Fig. (9) Ventral view of male catfish (*Clarias lazera*) showing the enlargement of the genital papilla during the breeding season . a- Urogenital papilla b-anal opening.

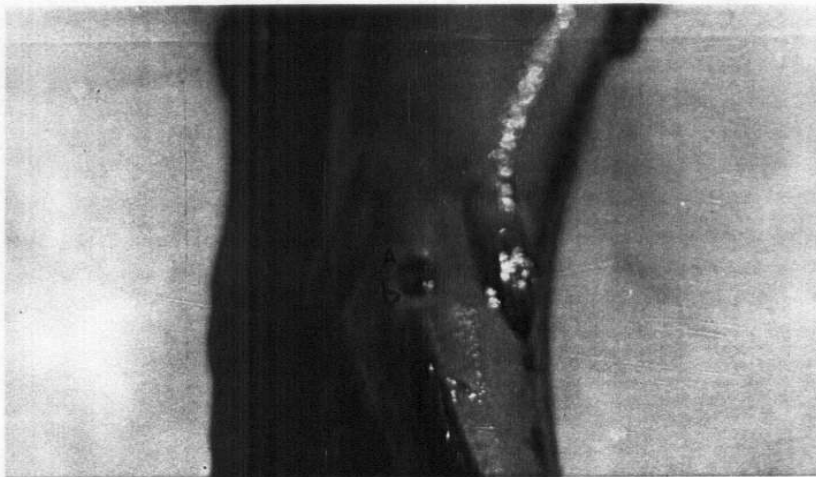

Fig.. (10) Ventral view of female catfish (*Clarias lazera*) showing the genital opening during the breeding season a-genital opening (ovipore) b-anal opening.



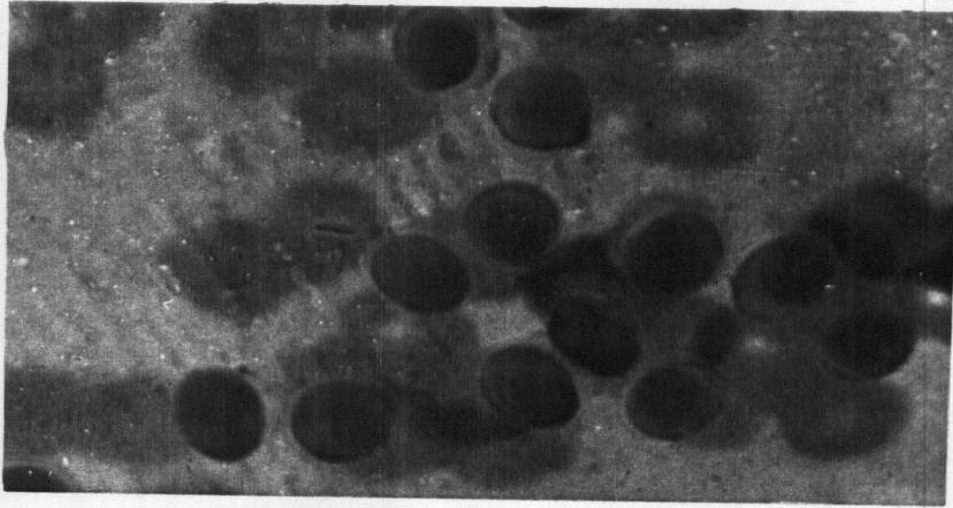

Fig.. (11) Fully ripened non fertilized eggs of *Clarias lazera*.

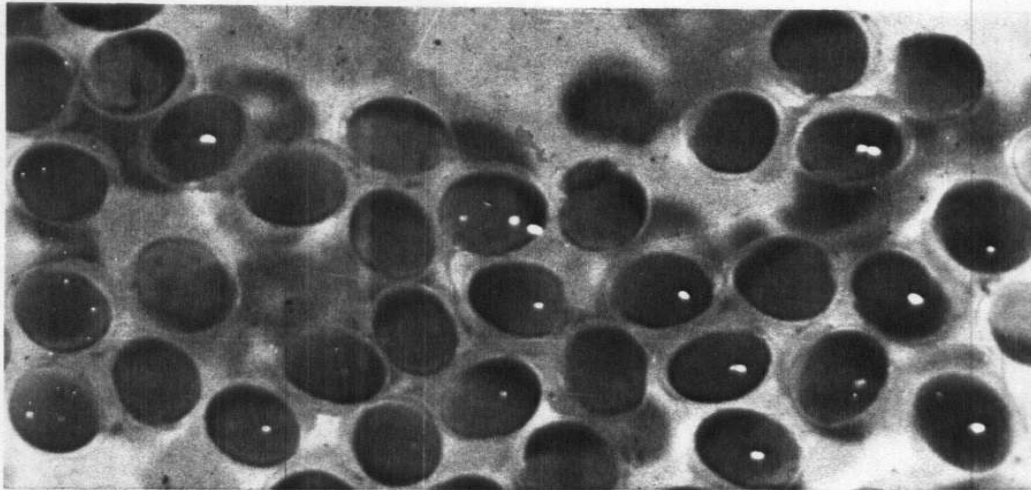

Fig.. (12) Fertilized eggs of *Clarias lazera*.

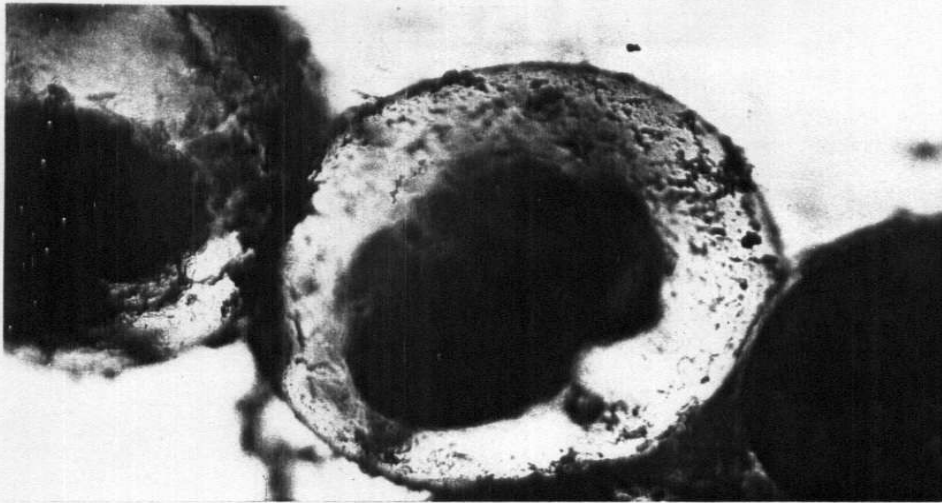

Fig.. (13) Morula stage (10 hrs after incubation ).

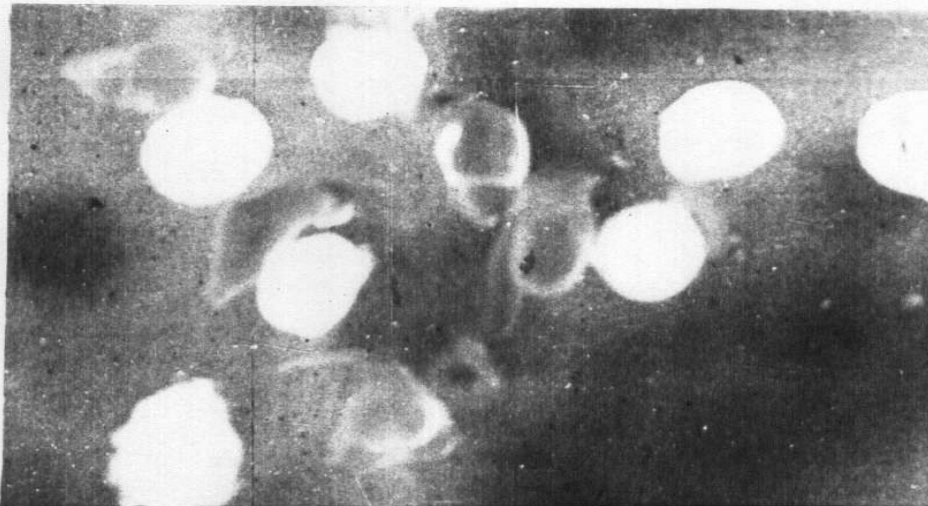

Fig.. (14) Normal larva of *Clarias lazera* immediately after hatching (24 hrs. old).

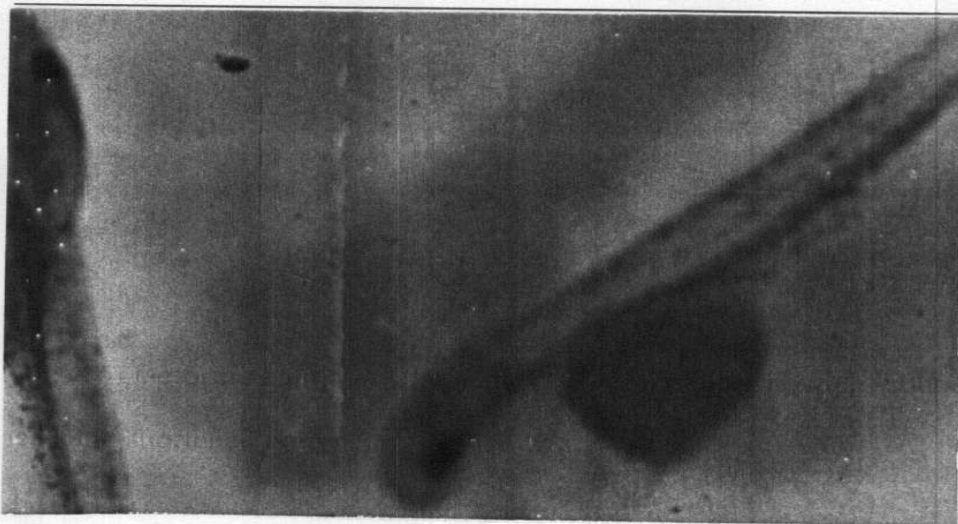

Fig.. (15) Normal larva of *Clarias lazera* (48 hrs old).

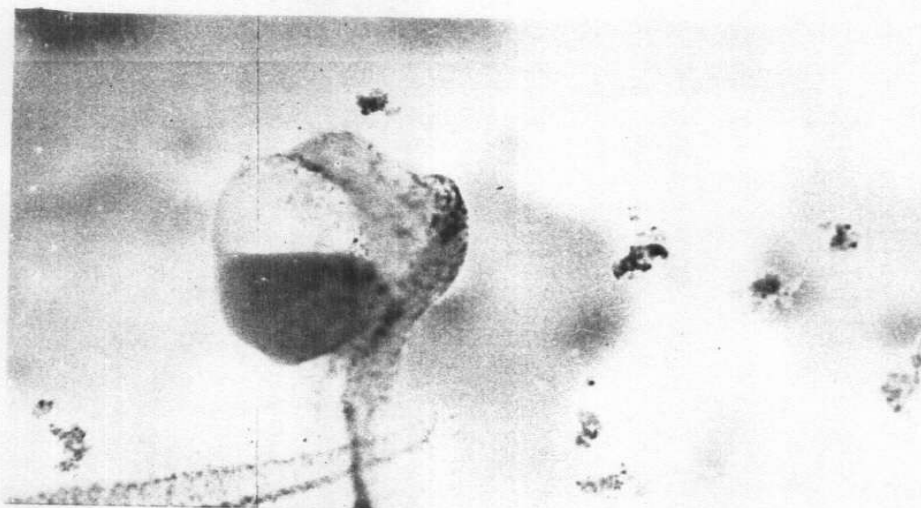

Fig.. (16) Deformed larva of *Clarias lazera* (48 hrs. old) showing enlarged head and shortened body.

---

## Discussion

Some problems encountered with the artificial breeding of Clariid species include induction programs, development of suitable hatching procedures, adhesion of fertilized eggs during incubation and also the difficulty of obtaining milt from males. Limited success was achieved in stripping male Clarias for obtaining enough amount of milt due to its anatomical structure (*Van der wall,1978*) and the practice of sacrificing Clariid males for egg fertilization is commonly used (*Teugles,1982*). Moreover, the mean survival rate of developing eggs that had been fertilized by stripping males over them was found to be 19% lower than that of eggs fertilized with crushed testes (*Van der Wall,1985*).

Most bony fishes held in confined water, either in culture ponds or in the laboratory, do not reproduce spontaneously under these conditions, the gonads undergo normal growth and development, but the final event of maturation and ovulation in females and spermiation in males do not occur (*Donaldson and Hunter, 1983*). These changes are initiated by surge in gonadotropin (GTH) secretion (*Crim et al.,1975 ; Van Oordt et al.,1987*), which somehow is lacking in fish kept in captivity . So in artificial breeding of fish, the surge in GTH is usually stimulated by supplementing GTH exogenously. Accordingly, induced breeding by hypophysation (Using crude pituitary extract) as a source of exogenous gonadotropin is the standard practice for fish culture (*Chondar,1980*).

The present study demonstrated that, maturation of *Clarias lazera* oocytes can be induced in vitro. A joint action of HCG (100 I.U./ml) followed 6 hrs later by the addition of either  $\Delta^5$ -pregnen-3 $\beta$ -ol-20-one (3 $\mu$ g/ml), 5 $\beta$ -androstane-3,17-dione (1 $\mu$ g/ml) or 4-pregnen-20 $\beta$ -ol-3-one caused a significant increase in the oocyte diameter indicating oocyte maturation as compared to that of control. The pre-addition of HCG to the incubation media seem to be of certain significance since it was previously suggested by *Morrill et al.* (1977) that the gonadotropin hormones may make the receptors on the oocyte surface more sensitive to steroid hormone.

HCG has been used effectively in fish reproduction. HCG alone caused in vivo gonad maturation of *Mugil cephalus* (*Shehadeh et al.*, 1973), stimulates vitellogenesis in the ovary of *Gasterosteus aculeatus* (*De Vlaming, 1974*) and egg maturation and ovulation in the Chichlid *Tilapia nilotica* (*Babiker and Ibrahim, 1979*). On the other hand, the results of an in vitro study (*Epler, 1981b*) indicated that HCG alone at a dose of 100 i.u./ml is not effective in inducing oocyte maturation in Carp. However, HCG in combination with CPH caused a statistically significant increase in the percentage of mature Carp oocytes (*Epler et al., 1986*). The results of the present study indicate that HCG (100i.u./ml) alone is ineffective in stimulating oocyte maturation which

may indicate species variation in the effectiveness of HCG in this respect.

In the present study, (in vitro) maturation of *Clarias lazera* oocytes was induced by the addition of HCG as a source of gonadotropin followed by the addition of  $\Delta^5$ -pregnen-3 $\beta$ -ol-20-one or 4-pregnen-20 $\beta$ -ol-3-one as a source of maturation induced steroid. Both  $\Delta^5$ -pregnen-3 $\beta$ -ol-20-one and 4-pregnen-20 $\beta$ -ol-3-one are derivatives of progesterone hormone. Other progestin derivatives such as 17  $\alpha$ -hydroxyprogesterone was found to be effective in inducing GVBD in oocytes of Ayu (*Plecoglossus altivelis*), Amgo salmon (*O. rhodurus*) and Rainbow trout (*S. gard.*) (*Nagahama et al., 1983*).

It has been established in Cypriniform and Salmoniform teleosts that, the pre-ovulatory rise in serum gonadotropin (either natural or induced), stimulate the ovarian production of 17  $\alpha$ -hydroxy progesterone and 17 $\alpha$ -hydroxy, 20 $\beta$ -dihydroxy progesterone in Carp (*Breton et al., 1983; Kim and Doblen, 1985; Levavi-Zeermomsky and Yaron, 1986*) and in African Catfish, Order Siluuriiformes (*Lambert and Van Der Hurk, 1982*).

In some fish species in vitro studies have shown that, of all steroid so far investigated 17 $\alpha$ -hydroxy, 20 $\beta$ -dihydroxy-progesterone (17 $\alpha$ ,20 $\beta$ -P) is generally the most potent steroid in inducing oocyte maturation in brook trout, *Salvelinus fontinalis* (*Duffy and Goetz, 1980*), Rainbow trout

and Pike, *Esoxx lucius* (*Fostier et al.,1973; Jalabert, 1976*), Yellow Perch, *Perca flavescens* and Carp (*Epler,1981a,b*), Ayu, *Plecoglossus altivelis*, Amago salmon, *Oncorhynchus rhodurus* and Goldfish (*Nagahama et al.,1983*).

Besides, *Barry et al. (1995)* studied the effect of some steroids on the in vitro maturation of the Wallaeye oocytes and they found that, the two most potent steroids for inducing germinal vesicle breakdown (GVBD) were  $17\alpha, 20\beta$ -dihydroxy-4-pregnen-3-one and  $17\alpha,20\beta,21$ -trihydroxy-4-pregnen-3-one.

In the present study, the effective steroids which induce in vitro maturation of the African Catfish oocytes were the  $\Delta^5$ -pregnen- $3\beta$ -ol-20-one and 4-pregnen- $20\beta$ -ol-3-one, these two steroids may act as precursors to other maturation induced steroids as  $17\alpha,20\beta$ -dihydroxy-4-pregnen-3-one or  $17\alpha,20\beta,21$ -trihydroxy-4-pregnen-3-one, which were reported to be the most potent steroids used to induce oocyte maturation in Walleye (*Barry et al., 1995*).

In vitro studies by *Schoonen et al.(1987)* showed that when African catfish oocytes were incubated with pregnenolone as steroid precursor, the oocytes synthesized progesterone,  $17\alpha$ -,  $20\beta$ -dihydroxy-4-pregnen-3-one and  $17\alpha$ -hydroxy progesterone.

Also,  $5\beta$ -androstane-3,17-dione ( $1\mu\text{g/ml}$ ) caused significant maturation changes in catfish oocytes. This steroid is considered as

synthetic derivative of testosterone. *Schoonen et al. (1987)* studied the effect of in vitro incubation of *Claris garipinus* oocytes with (H<sup>3</sup>)-androstenedione as precursor of testosterone. The results showed that the oocytes synthesized progesterone, androstenedione, testosterone, estradiol-17 $\beta$  and esterone beside several 5 $\beta$ -reduced steroids, which act as maturation induced steroids.

*Goswami and Sundararaj (1974)* found that, 11-ketotestosterone and 19-nortestosterone possessed only a minimal maturation-inducing ability. In earlier studies, testosterone was shown to be ineffective in inducing oocyte maturation under in vivo (*Sundararaj and Goswami, 1966*) and in vitro Conditions (*Goswami and Sundararaj, 1971a*). Besides, it was reported that in fishes, 11-ketotestosterone is a more potent androgen than testosterone (*Arai, 1967*). The results of the present study further showed that, of all testosterone and progesterone precursors tested, significant maturation inducing ability was confined only to  $\Delta^5$ -pregnen-3 $\beta$ -ol-20-one (3 $\mu$ g /ml) and 4-pregnen-20 $\beta$ -ol-3-one (2 $\mu$ g /ml) and 5 $\beta$ -androstane 3,17-dione (1 $\mu$ g /ml).

Serotonin have been known as "non-adrenergic, non cholinergic" transmitter in mammalian autonomic nervous system (*Gerschon, 1981*) and its presence in Piscine autonomic nervous system was proved histochemically (*Longer et al., 1979; Holmgren and Nilson, 1981*). In *Tilapia nilotica* serotonin at a final concentration of (10<sup>-3</sup> M) had a



stimulatory effect on ovarian contractile activity in vitro during Tilapia spawning season which indicated the presence of 5HT receptors in the ovarian tissue (*Nemetallah and Ahmed,1987*). However, the present study did not demonstrate a stimulatory effect of serotonin on oocyte maturation.

In the present study a trial was made to determine the suitability of carp pituitary homogenate (CPH.) to induce maturation and ovulation in females and spermiation in males in African catfish (*Clarias lazera*) and to evaluate the quality of produced eggs with respect to fertilizability and hatchability of *Clarias* eggs.

The result obtained showed that, a single injection of CPH caused oocyte maturation and ovulation and spermiation in all injected fish, giving an overall response of 100%.

The CPH has been used to induce oocyte maturation and ovulation in several fish species such as *Heteropneustes fossilis*, *Clarias batrachus*, *Clarias lazera* (*Eding et al.,1982*) and *Clarias macrocephalus* (*Mollah and Tan,1983*).

In grey mullet (*Mugil cephalus*) hormonal intervention is presently the most effective method for inducing final maturation and successful spawning. The most reliable and cost-effective method for spawning mullet is an acute hormonal therapy combining either of Carp pituitary homogenate with human chorionic gonadotropin (HCG) or CPH with

---

luteinizing hormone releasing hormone analogue (LHRHa), in both case CPH is injected as the priming dose (*Lee et al.,1988*).

As the CPH was used to induce oocyte maturation and ovulation in several fish species, it was used also to induce oocyte maturation in vitro in *Oreochromis niloticus* (*Ahmed et al., 1987*) who found that the pre-addition of CPH to the incubation medium containing oocytes treated with 17 $\alpha$ -hydroxy-progesterone induced maturation changes in *O.niloticus* oocytes. *Morrill et al.(1977)* suggested that CPH may make receptors on the oocytes surface more sensitive to steroid hormones.

Earlier in vitro studies on carp intrafollicular oocyte maturation (*Epler, 1981b*) showed that HCG did not increase the percentage of mature oocytes. However, a joint action of this hormone with carp pituitary homogenate caused a significant increase in the percentage of mature oocytes. Also, in the same species, when HCG was used at a certain dose (100I.U/ml) did not produce maturation of the oocyte but the CPH at the same dose was effective in inducing a certain degree of oocyte maturation. *Colombo and Colombo (1977)* attributed the oocyte maturation efficiency of the pituitary homogenate to the increase in number and affinity of the receptors on the follicular cells of the oocytes or to its stimulatory effect on the initiation and acceleration of steroid biosynthesis needed for oocyte maturation, which indicate the synergistic effect of pituitary gonadotropin with maturation induced steroid (MIS) as

---

suggested by *Jalabert (1976)* in the rainbow trout and by *Epler (1981c)* in the carp.

The induction of oocyte maturation and collection of milt were among the major problems in the artificial breeding of African catfish beside the clumping of the egg mass which lower the egg hatchability . The eggs have a sticky material which adhere eggs together thus preventing oxygenation of eggs and respiration of the developing embryos (*Dupree 1984*). To overcome this problem, the fertilized eggs were treated with 0.3 –0.5% solution of alkaline protease enzyme for 2-3 minutes after 10-12hrs from egg incubation. This procedure was reported to dissolve the sticky layer on the eggs and allow them to float freely (*Staff, 1983*). However, the expensive price of protease enzyme and the difficulty of obtaining it by the fish practitioners made this method not economic and directed our attention to look for another enzyme preparation which fulfill this criteria. In the present study, egg adhesion was overcome by the use of alpha chymotrypsin enzyme as a proteolytic enzyme to dissolve the sticky material adhering the eggs together during incubation. This treatment was very effective in increasing the percentage of hatching eggs giving a high yield of normal catfish fry.

The availability of alpha chymotrypsin in drug stores and its handy price made the present technique a simple and applicable one in the field of catfish aquaculture.

---

## SUMMARY

One of the most serious problems encountered in fish farming is the difficulty of obtaining fry in large numbers for catfish breeding programs on commercial scale. The main problems include:-

- 1- Catfish oocytes have sticky layer which adhere them together thus preventing proper aeration and lower egg hatchability.
- 2- The need of obtaining large number of mature oocytes whether through induction of spawning or through in vitro maturation and their subsequent fertilization with proper amount of milt to obtain large number of fry suitable for intensive catfish farming.

The present study was undertaken to study the possible use of some hormones to induce oocyte maturation in vitro and to find a suitable method to overcome the problem of egg adherence .

### **First experiment :-**

A total of 90 female Catfish were used. Oocyte diameter was determined after immersion of a small portion of the ovary in a clearing solution. Ovarian fragments (180±20 oocytes ) were treated with alphachymotrypsin enzyme (5mg/100ml water for 5 minutes) at room temperature . This treatment removed the sticky layer around the eggs. Eggs were then incubated with HCG (100I.U/ml Earle's sol.) for 6 hours at room temperature (25±1.0 °C ) after which eggs were allocated to one

of 9 groups. Each egg group was incubated with one of the following hormones :-

$\Delta^5$  Pregnen-3 $\beta$ -3 $\beta$ -ol-20-one, Androstenedione, 5 $\beta$ -androstane-3,17-dione, 4-pregnen-20 $\beta$ -ol-3-one, testosterone, Dehydroisoandrosterone, 5-hydroxy tryptamine (serotonin), 5  $\alpha$  androstan-17 $\beta$ -ol-3-one & 5  $\alpha$ -pregnane-3 $\beta$ , 20  $\alpha$ -diol.

Three concentrations of each hormone were used (1, 2 and 3  $\mu$ g/ml Earle's solution). After incubation with different hormones, the oocytes were cleared in clearing solution to determine the egg diameter and the degree of oocyte maturation.

**The results obtained revealed the following :-**

1-Incubation of Catfish oocytes in Earle's solution containing  $\Delta^5$  - pregnen-3 $\beta$ -ol-20-one (3 $\mu$ g/ml), 5 $\beta$ -androstane-3,17-dione (1 $\mu$ g/ml) and 4-pregnen-20 $\beta$ -ol-3-one (2 $\mu$ g/ml) resulted in significant increase in oocyte diameter ( $P < 0.01$ ).

2-A non significant increase in the egg diameter resulted on the addition of  $\Delta^5$ -pregnen-3 $\beta$ -ol-20-one (2 $\mu$ g/ml) ,testosterone (3 $\mu$ g/ml) ,5 $\alpha$ -androstan-17 $\beta$ -ol-3-one (2 $\mu$ g/ml) and 5  $\alpha$ -pregnene-3 $\beta$ ,20 $\alpha$ -diol (1  $\mu$ g/ml).

3- HCG(100I.U./ml), $\Delta^5$ -pregnen-3 $\beta$ -ol-20-one(1 $\mu$ g/ml) ,androstenedione (1 , 2 or 3  $\mu$ g/ml) 5 $\beta$  -androstane-3,17-dione (1 or 3  $\mu$ g /ml), testosterone (1 or 2  $\mu$ g/ml), dehydroiso androsterone (1 ,2 or 3  $\mu$ g/ml).

---

serotonin (1,2 or 3  $\mu\text{g/ml}$ ), 5  $\alpha$ -pregnane-3 $\beta$ -20 $\alpha$ -diol (2 or 3  $\mu\text{g/ml}$ ), 5  $\alpha$ -androstan-17 $\beta$ -ol-3-one (1 or 3  $\mu\text{g/ml}$ ) did not significantly affect the oocyte diameter as compared to that of control .

### **Experiment II**

50 male and 50 female Catfish were injected with carp pituitary homogenate (CPH). Ripe eggs were collected from spawned females and fertilized using testicular sperms from donor males. The fertilized eggs were incubated in Zug-jars at room temperature for 10 hours after which they were treated with alpha chymotrypsin to disperse egg mass. Eggs were further incubated for 38 hours till hatching occurred. The number of hatched eggs was determined 24 hrs after incubation. The number of normal and deformed fry was also recorded after 48 hrs.

**The results obtained revealed that :-**

- 1- All female catfish ovulated in response to CPH .
- 2- All male catfish injected with CPH had enlarged testis filled with milt.
- 3- Eggs incubated for 10 hrs developed into morula and hatched after 24 hrs into yolk stage larvae. After 48 hrs the percentge of normal fry and deformed fry was  $87 \pm 3.1$  and  $12 \pm 1.9$  % respectively.

---

**From the fore-mentioned results it was concluded that :-**

- 1- In vitro maturation of catfish oocytes can be induced in vitro by the joint action of HCG either with  $\Delta^5$ -pregnen-3 $\beta$ -ol-20-one (3 $\mu$ g/ml) or 5 $\beta$ -androstane-3,17-dione (1 $\mu$ g/ml) or 4-pregnen-20 $\beta$ -ol-3-one (2 $\mu$ g/ml)
- 2- Carp pituitary homogenate induced gonadal maturation to both males and females catfish injected during the breeding season.
- 3- Alpha chymotrypsin enzyme was effective in removing the sticky layer from the eggs and prevented its adherence.

---

## References

- Ahmed, I.I., Nemetallah, B.R. and Mohamed, M.M. (1987):* Preliminary observation on hormonal induction of in vitro oocyte maturation in *Oreochromis niloticus*. J.Egypt. Vet. Med. Ass. 47, No 1&2, 481- 488.
- Ahsan , S.N. (1966):* Cyclical changes in the testicular activity of the lake Chub , *Couesius plumbeus* (Agassiz) .Canadian Journal of Zoology 44:149:159.
- Anderson , E. (1967):* The formation of the primary envelope during oocyte differentiation in teleosts. Journal of Cell Biology 35:193-212.
- Arai, R. (1967):* Androgenic effects of 11- keto-testosterone on some sexual characteristics in the teleost, *Oryzias latipes*. Annot. Zool. Jop. 40: 1-5.
- Babiker, M.M. and Ibrahim, H. (1979):* Studies on the biology of reproduction in the Cichlid *Tilapia nilotica* (L.) : effects of steroids and tropic hormones on ovulation and ovarian hydration. J. Fish , Biol ., 15: 21-30 .
- Bara, G.(1965):* Histological localization of a  $\rho^5$  - 3B-hydroxy-steroid dehydrogenase in ovaries of teolest fish *Scomber-scomber* L. General and Comparative Endocrinology 5:284-296.



**Bara, G. (1969):** Histochemical demonstration of 3 $\beta$ , 11 $\beta$ - and 17 $\beta$  hydroxysteroid dehydrogenase in the testis of *Fundulus heteroclitus*. *General and Comparative Endocrinology* 13:189-200.

**Barr, W. (1963):** The endocrine control of sexual cycle in the Plaice, *Pleuronectes platessa*(L). II. The endocrine control of oogenesis. *General and Comparative Endocrinology* 3:305-215.

**Barry, T.P., Malison, J.A., Lapp, A.F. and Lynne (1995):** Effects of selected hormones and male Cohorts on final oocyte maturation, ovulation and steroid production in Walleye (*Stizostedion Vitreum*). *Aquaculture*, 138:331-347.

**Billard, R., Richard, M. and Rombauts, P.R. (1982):** Inhibition of spermatogenesis and vitellogenesis in rainbow trout by hormonal additives in the diet. *Prog. Fish Cult.*, 44:15-18

**Boulenger, G. A. (1907):** Fishes of the Nile. Hugh and Rees Ltd. London.

**Breton, B. and Weil, C. (1973):** Effects du LH, FSH-RH synthétique et d'extraits hypothalamiques carpe sur la sécrétion d'hormone gonadotrope in vivo chez la carpe (*Cyprinus carpio*) C.R. Acad. Sci. Paris .Ser. D, 277: 2061-2064.

**Breton, B., Jalabert, B., Bieniarz, K., Sokolowska, M. and Epler, P. (1983):** Effect of synthetic LH- RH analogue on plasma gonadotropin levels and maturational response to 17 $\alpha$ -hydroxy-20 $\beta$  - dihydroprogesterone. *Aquaculture*, 32:105-114 .

---

**Bruton, M.N. (1979):**The breeding biology and early development of *Clarias gariepinus* (pisces: Clariidae) in lake Sibaya, South Africa, with a review of breeding in species of the subgenus *Clarias* (*Clarias*). Trans. Zool. Soc. Lond., 35:1-45.

**Busson- Mabillot, S. (1973):** Evolution des enveloppes de l'ovocyte et de l'oeuf chez un poisson téléostéen. Journal de Microscopie 18 : 23 – 44 .

**Chondar, S. L. (1980):** Hypophysation of Indian Major Carps, 2<sup>nd</sup> Edn. Satish Book Enterprises , Agra, India, pp. 1-146.

**Clemens, H.P. and Sneed, K.E. (1962):** Bioassay and use of pituitary materials to spawn warmwater Fish.. Res. Rep. U.S. Fish Wildlife Serv. No. 61, 30pp.

**Colombo , L. and Colombo, P. (1977):** Gonadal steroidogenesis in teleost fishes . Invest. Pesq., 4:147-164.

**Colombo, L., Colombo- Belvédère, P. and Arcaresse, G. (1978):** Emergence of ovarian 11-deoxycorticosteroid biosynthesis at ovulation time in the Sea bass, *Dicentrarchus labrax* L. Ann. Biol. Anim. Biochim. Biophys. 18 : 937-941.

---

***Crim, L.W. and Evans , D.M. (1979) :***Stimulation of pituitary gonadotropin by testosterone in Juvenile rain bow trout ( *Salmo gairdneri* ) . Gen. Comp. Endocrinol. 37 : 192- 196.

***Crim, L.W., Evans, D.M., Coy, D.H. and Schally, A. V. (1981):*** Control of gonadotropin hormone release in trout: influence of synthetic LH-RH and LH-RH analogues in vivo and invitro. Life Sci. 28 : 129-135.

***Crim, L.W., Sutterlin, A. N., Evans, D. M. And Weil, C. (1983):*** Accelerated ovulation by pelleted LH-RH analogue treatment of spring spawning rain bow trout (*Salmo-gairdneri* ) held at low temperature. Aquaculture 35: 299-307.

***Crim, L. W., Watts , E. G. and Evans, D. M. (1975) :*** The plasma gonadotropin profile during sexual maturation in a variety of Salmonid fishes . Gen . Com. Endocrinol., 27 : 62-70.

***Cruickshank, R., Duquid, J.P., Marmion , B.P. and Swain, R. H. A. (1973):*** Medical Microbiology ( vol.1) : Microbial Infection, 12<sup>th</sup> Ed . Churchill living stone, Edinburgh.

***De Vlaming , V.L. (1974):*** Environmental and endocrine control of teleost reproduction . In : Schreck CB (ed ) control of six of fishes . Virginia Polutechnic Institute and state University, Blacksburg, p 13 – 83.

**Dia, A.K., Hem, S. and Legendre, M. (1986):** Les recherches en aquaculture lagunaire. Encodet Ivoire. Etudes Scientifiques Ed. et publie. des press Jansuitesen Egypt (IHS).

**Dodd, J.M. (1977) :** The structure of the ovary of non-mammalian vertebrates . In : Zuckerman S, Weir-BJ (eds). The ovary , 2<sup>nd</sup> ed . Academic press, New York , Vol. 1, P 219-263.

**Donaldson , E.M. (1973):** Reproductive endocrinology of fishes . American Zoologist 13:909-927.

**Donaldson , E.M. and Hunter, G. A. (1983):** Induced final maturation, ovulation and spermiation in cultured fish . In : W.S. Hoar and D.J. Randall ( Editors ) , Fish physiology, Vol . 9B . Academic Press, New York, pp. 351- 403 .,

**Donaldson, E.M., Hunter, G.A. and Dye, H.M. (1981):** Induced ovulation in Coho salmon (*Oncorhynchus kisutch*) II. Preliminary study of the use of LH-RH and two high potency LH.RH analogues. Aquaculture, 26:129- 141 .

**Dowider, N.M., Zaki, N.I. and Abdalla, A. (1985):** Sexual maturity , gonadal cycle and fecundity of *Clarias lazera* in lake Manzalah First Int. Conf. App. Sci. Vol. IV.

**Duffy , R. J. and Goetz, F.W. (1980) :** The in vitro effect of 17 $\alpha$ -hydroxy - 20 B- dithydroprogesterone on germinal viscle breakdown in brook trout (*Salvelinus fortinalis*) oocytes . Gen. Comp. Endocrinol. , 41 : 563- 565.

---

**Dupree, H.K.(1984)** : Third report to the fish farmers .United States Department of the Interior, Fish and Wildlife Service.

**Eding, E.H., Janssen, J.A.I., Kleine Staarman, G.H. J. and Richter, C.J.J.(1982)**: Effects of human chorionic gonadotropin(HCG) on maturation and ovulation of oocytes in the clarias lazera (C. et V) In: C.J.J. Richter and H.J. th. Goos (Editor), Proc. Int .Symp. Reproductive Physiology of fish. PUDDOC, Wageningen, p. 195.

**Elliott, J.A.K., Bromage, N.R. and Whitehead, C. (1979)**: Effect of estradiol -17B on serum calcium and vitellogenin levels in rainbow trout . Journal of Endocrinology 83:54p-55p .

**Emmersen, J., Korsgaard, B. and Petersen, I. (1979)**: Dose response kinetics of serum vitellogenin , liver DNA , RNA, protein and lipid after induction by estradiol-17B in male Flounders (*Platich thys- flesus L .*). Comparative Biochemistry and Physiology 12 :1-6 .

**Epler, P.(1981<sub>a</sub>)**: Effect of steroid or gonadotropic hormone on the maturation of carp ovary. Part 11. Effect of fish and mammalian gonadotropin on the maturation of carp oocytes in vitro. Pol. Arch. Hydrobiol., 28:95-102.

---

**Epler, P.(1981<sub>b</sub>):** Effect of steroid or gonadotropic hormone on the maturation of carp ovary Part 111. Effect of steroid hormones on the carp oocyte maturation in vitro . Pol . Arch. Hydrobiol., 28 : 103 – 110 .

**Epler, P. (1981<sub>c</sub>):** Effect of steroid and gonadotropic hormones on the maturation of carp ovaries . Part IV. Acombined action of steroid hormones and HCG or fish hypophysial homogenate on Carp oocyte maturation in vitro Pol. Arch. Hydrobiol. 28:111-117.

**Epler, P., Sokolowska, M.,Popek, W. and Biernarz, K.(1986):**Joint action of Carp (Cyprinas carpitol) pituitary homogenate and human chorionic gonadotropin (HCG) in Carp oocyte maturation :In vitro and in vivo studies. Aquaculture 51:133-142.

**Flügel, H.(1976<sub>a</sub>):** Licht und elektronenmikroskopische Untersuchungen an Oozyten und Eiern einiger Knochenfische. Zeitschrift Für Zellforschung und mikroskopische Anatomie 83 : 82 –116 .

**Flügel,H.(1967<sub>b</sub>):** Elektronenmikroskopische. Untersuchungen an dien Hullen der Oozyten und Eier des Flussabarsches Perca fluviatilis Zellforschung und mikroskopische. Anatomie 77:244-256.

**Fostier, A., Jalabert, B. and Terqui, M. (1973):** Action predominante d'un d'érivé hydroxylé de la progesterone sur la maturation in vitro de oocytes de la Truite arc-en-ciel, *Salmo gairdneri* .C.R.Hebd. Seances Acad – Sci., 277 : 421 – 424.

**Fostier, A., Jalabert, B., Billard, R., Breton, B. and Zohar, Y. (1983):** The gonadal steroid. In W. S. Hoar, D.J. Randall and E.M. Donaldson (Editors) , Fish Physiology. Vol. IXA, Academic Press, NewYork, pp. 351-403

**Franchi, L. L., Mandl, A. M., Zuckerman, S. (1962):**Ovarian development and oogenesis .In :Zuckerman S (ed). The ovary . Academic press ,London ,Vol. 1, pp 1-88 .

**Garcia, L.M.B. (1990):** Advancement of sexual maturation and spawning of sea bass, *Lates calcarifer* ( Bloch ) , using pelleted luteinizing hormone- releasing hormone analogue and 17  $\alpha$ -methyltestosterone. *Aquaculture*, 86 : 333- 345.

**Gerschon, M.D. (1981):** “ The enteric nervous system “ *Annual Review Neuroscience.*, 4 : 227-272.

**Goetz, F.W. and Theofan, G. (1979 ):** In vitro stimulation GVBD and ovulation of yellow perch ( *Perca flavescens* ) oocytes . Effects of 17  $\alpha$  - hydroxy – 20 B – dihydroxy progesterone and prostaglandins . *Gen, Comp. Endocrinol .*, 37 : 273- 285 .

---

**Gokhale ,S.V.( 1957):** Seasonal histological changes in the gonads of the whiting *Gadus merlangus* L. and the Norway pout *G.esmarkii* Nilsson .Indian Journal of Fisheries 4:92-112.

**Goswami, S.V. and Sundararaj, B.I.(1971):** In Vitro maturation and ovulation of oocytes of the catfish, *Heteropneustes fossilis* ( Bloch ) :Effect of mammalian hypophyseal hormones , catfish pituitary homogenate, steroid precursors of metabolites and gonadal and adrenocortical steroids. J. EXP. Zool, 178 : 476-477.

**Goswami, S.V. and Sundararaj, B.I. (1974):** Effect of C 18, C19, and C21 steroids on in vitro maturation of oocytes of the Catfish, *Heteropneutes fossilis* ( Bloch ) . Gen . Comp. Endocrinol., 23 : 282-285 .

**Gresik,E.W.(1973):** Fine structural evidence for the presence of never terminals in the testis of the teleost *Oryzias latipes* . General and Comparative Endocrinology 21:210-213.

**Guiral, D. (1983):** Physicochimie et biogéochimie des eaux et des sédiments a la station d'aquaculture de layo(Lagune E brié, Cote d' Ivoire).Doc.Sci.Cent .Rech.Oceanogr.Abidjan. 14(1):1-29.

**Guraya, S.S.(1965):** Acomparative histochemical study of fish (*Channa marulius* ) and amphibian (*Bufo stomatictus*) oogenesis .Zeitschrift fur Zellforschung und mikroskopische Anatomie 65:662-700.



**Guraya, S.S. (1978):** Maturation of the follicular wall of non-mammalian vertebrates .In : Jones RE (ed). The Vertebrate Ovary . Plenum Press . New York , ch 8,p261-329.

**Guraya, S.S., Kaur,R. and, Saxena,P.K.(1975):** Morphology of ovarian changes during the reproductive cycle of fish, *Mystus tengara* (Ham.) . Acta Anatomica 91:222-260.

**Haas, E.(1982):** DerKarpfen und seine Nebenfische leopold stocker verluy pp 268.

**Harvey, B.J. and Hoar, W.S. (1980):** Reproduction provoquee chez les poissons : Theorie et paratique. I.D.R.C., Ottawa, Ont. pp. 48.

**Hickling ,C.F.(1936):** Seasonal changes in the ovary of the immature hake ,*Merluccius merluccius* L. Journal of Marine Biological Association of the United Kingdom 20:443-461.

**Hirose , K.(1976):** Endocrine control of ovulation in medaka (*Oryzias latipes* ) and ayu ((*Plecoglossus altivelis*)).J.Fish.Res. Board Can., 33:989-994.

**Hirose, K. and Ishida, R.(1974):** Induction of ovulation in the ayu (*Plecoglossus altivelis*) with LH releasing hormone (LHRH). Bull Jpn. Soc. Sci Fish., 40: 1235- 1240.

**Hoar, W.S.(1969):** Reproduction .In: Hoar, W. S., Randall DJ(eds) Fish physiology .Academic Press New York Vol 3 ,p1-72 .

---

**Holmgren, S. and Nilson, S. (1981):** On the non-adrenergic innervation of the rainbow trout stomach. *Comparative Biochemistry and Physiology*, 70: 56-69.

**Hori, S.H., Kodama, T. and Tanahashi, K. (1979):** Induction of vitellogenin synthesis in goldfish by massive dose of androgens. *General and Comparative Endocrinology* 37:306-320.

**Hurley, D.A. and Fisher, K.C. (1966):** The structure and development of the external membrane in young eggs of the brook trout *Salvelinus fontinalis* (Mitchell). *Canadian Journal of Zoology* 44:173-190.

**Hyder, M. and Kirschner, S. (1969):** Histological studies on the testis of *Tilapia leucosticta* and other species of the genus *Tilapia* (pisces:teleostei). *Transaction of American Microscopical Society* 88:211-231.

**Idler, D.R. and Ng, T.B. (1979):** Studies on two types of gonadotropins from both Salmon and carp pituitaries. *General and Comparative Endocrinology* 38:421-440.

**Iwamatsu, T. (1978):** Studies on oocyte maturation of the medaka, *Oryzias latipes*. VI. Relationship between the circadian cycle of oocyte maturation and activity of the pituitary gland. *J. Exp. Zool.*, 206:355-364.

---

**Jalabert, B.(1976):**In vitro maturation and ovulation in Rainbow trout (*Salmo gairdneri*) northern pike(*Esox lucius*) and gold fish (*Carassius auratus*) .*J.Fish, Res.Boad Can.*, 33 : 974-988.

**Jalabert, B. and Breton, B.(1973):** In vitro maturation of pike (*Esox lucius*)oocytes. *Gen.Comp.Enocrinol.* 22,391(Abstr.).

**Jalabert, B., Breton, B. and billard, B.(1974):** Dosage biologique des hormones gonadotropic de ovocytes de truite. *Ann,Biol.Anim.Biochem.Biophys.*14 :217-228.

**Jalabert, B., Bry, C., Szollosi, D.and Fostier, A. (1973):** Étude comparée de l' action des hormones hypophysaires et stéroïdes sur la maturtion invitro des oocytes de la Truite et du Carassin (*Poisson Téléostéens*). *Ann, Biol . Anim. Biochim. Biophys.*, 13:59-72.

**Jared , D.W. and Wallace, R.A.(1968):** Comparative Chromatography of yolk protein of teleosts . *Comparative Biochemistry and Physiology* 24:437-443.

**Jollie ,W.P. and Jollie, L.G.(1964<sub>a</sub>):** The fine structure of the ovarian follicle of the oviviparous Poeciliid fish *Lebistes reticulatus*. 1.Maturation of follicular epithelium .*Journal of Morphology* 114:479-503 .

**Jollie ,W.P. and Jollie, L.G.(1964b):** The fine structure of the ovarian follicle of the oviviparous Poeciliid fish *Lebistes reticulatus*. II. Formation of the follicular pseudoplacenta. *Journal of Morphology* 114:503-526.

**Juario,J.V., Natividad,M., Qunitio, G.and Banno, J. (1979):** Experiments on induced spawning and larval rearing of the milkfish, *Chanos chanos* ( Forsskal ) in (1979. SEAFDEC Aquaculture Department. Q. Res. Rep., 3:1-13.

**Kime, D.E. and Dolben, I.P. (1985):** Hormonal changes during induced ovulation of the Carp, *Cyprinus carpio* . *Gen. Comp. Endocrinol .*, 58: 137 – 149 .

**Korfsmeier, K. H.(1966):** Zur genese des dottersystems in der oocyte von *Brachydanio rerio*. Autoradiographische untersuchungen. *Zeitschrift für Zellforschung und mikroskopische Anatomie* 71:283-296 .

**Kuo, C.M.(1982):** Induced breeding of grey mullet, *Mugil cephalus* L. In : C.J.J. Richter and M.J.Th. Goos ( Compilers), *Proc. Int. Symp. Reproductive Physiology of Fish*, Wageningen. The Netherland. PUDOC. Wageningen, pp. 181-184.

**Kuo, C.M.(1985):** A review of induced breeding of milk fish. In: C.S. Lee and I.C. Liao (Editors.) *Reproduction and Culture of Milkfish* .Oceanic Institute, Hawaii, and Tungkang Marine laboratory, Taiwan, pp, 57-77.

---

**Kuo, C.M., Nash, C.E. and Watanabe W.O. (1979):** Induced breeding experiments with milkfish, *Chanos chanos* (Forsskal) in Hawaiian waters. *Aquaculture*, 16:247-252.

**Kuo, C.M., Shehadeh, Z.H. and Nash, C.E.(1973):** Induced spawning of Captive grey Mullet ( *M. cephalus* L.) female by injection of Human chorionic gonadotropin ( HCG ). *Aquaculture*, 1:429-432.

**Lam, T.J. (1982):** Application of endocrinology to fish culture . *Can. J. Fish. Aquat. Sci.*, 39 : 111- 137 .

**Lam, T.J.(1984):** Artificial propagation of milk fish: present status and problems. In :J.V. Juario. R.P. Ferraris and L.V. Benitez (Editors), *Advances in Milkfish Biology and Culture*. Island Publishing House, Metro Manila, The Philippines, pp. 21-39.

**Lam, T.J., Pandey, S. and Hoar, W. S.(1975):** Induction of ovulation in gold fish by synthetic. luteinizing hormone- releasing hormone (LHRH). *Can. J. Zool.*, 53 : 1139 -1192.

**Lambert,J.G.D.(1966):** Location of hormone production in the ovary of the guppy, *Poecilia reticulata* .*Experientia* 22:476-477.

**Lambert, J. G. D.(1970):** The ovary of the guppy, *poecilia reticulata*. The granulosa cells as sites of steroid biosynthesis. *General and Comparative Endocrinology* 15:464-476.

***Lambert, J.G.D. and Van Den Hurk , R. (1982):*** Steroidogenesis in ovaries of African catfish, *Clarias lazera* , before and after a HCG- induced ovulation . In : C.J.J. Richter and H.J.th. Goos (Editors ) , Proc. Int. Symp. Reproductive Physiology of Fish, Wageningen, the Netherland, 2-6 August (1982)- PUDOC, Wageningen, pp. 99-102.

***Lee. C.S., Tamaru, C.S., Banno, J.E, and Kelley, C.D.(1986):*** Influence of chronic administration of LHRH analogue and / or 17  $\alpha$  - Methyltestosterone on maturation of milk fish, *Chanos chonos* . Aquaculture, 59: 147-159.

***Lee, C.S., Tamaru, C.S. and Kelley, C.D. (1988):*** The cost and effectiveness of CPH, HCG and LHRH.a on the induced spawning of grey mullet, *Mugil cephalus*. Aquaculture, 73 : 341-347.

***Lee, C.S, Tamaru, C.S., Kelley, C.D. and Banno, J.E. (1986):*** Induced spawning of milkfish, *Chanose chanos*, by a single application of LHRH. Analouge. Aquaculture, 58:87- 98.

***Lee, C.S., Tamaru, C.S., Miyamoto, G.T. and Kelley C.D. (1987):*** Induced spawning of greymullet (*Mugil cephalus*) by LHRH. a. Aquaculture, 62:327-336.

---

**Legendre , M.(1983):** Examen préliminaire des potentialités d'unsilure African *Heterobranchus longifilis* (Vanlenciennes, 1940) Pour l' aquaculture en milieu lagunaire. *Doc. Sci. Cent. Rech. Océonogr. Abidjan*, 14(2):97-107.

**Legendre, M.(1986):** *Seasonal changes in sexual maturity, fecundity and HCG- induced breeding of the catfish, Heterobranchus longifilis Val . (Clariidae) reared in Ébrié lagoon (Ivory Coast).* *Aquaculture*, 55:201- 213

**Lehri, G.K.(1968):** Cyclical changes in the ovary of the Catfish, *Clarias- batrachus*. *Acta. Anat.* 69 : 105 – 124 .

**Lemenn, F. and lamy, M. (1977):** Teleost fish (*Gobius niger*) vitellogenic protein in plasma and liver under hormonal treatment. *Annales d'endocrinologie* 37: 491- 492 .

**Levavi – Zermomsky ,B. and Yaron, Z. (1986):** Changes in gonadotropin and ovarian steroids associated with oocyte maturation during spawning induction in Carp. *Gen. Comp. Endocrinol.*, 62: 89-98 .

**Lin, L. T.(1984):** Studies on the induced breeding of milkfish (*Chanos chanos* Forsskal ) reared on ponds. *China Fish .*, 378 : 3 – 29 ( in Chinese, with English abstract )

**Lio, I. C., Juario, J.V., Kumagai s., Nakajima, H., Natividad, M. and Buri, P.(1979):** On the induced spawning and larval rearing of milkfish, *Chanos chanos* ( Forsskal ) . *Aquaculture*, 18 : 75- 93.

---

**Longer, M., Van Noorden, S., Palock, J.M. and Pearse, A. G. (1979):** Peptide hormone like immuno-reactivity in the gastrointestinal tract and endocrine pancreas of eleven teleost species . Cell Tissue Research, 199: 493-508.

**Manickam, P. and Joy, K.P. (1989):** Induction of maturation and ovulation by pimozide- LHRH analogue treatment and resulting high quality egg production in the Asian catfish, *Clarias batrachus*(L.) Aquaculture, 83:193-199.

**Marshall, A. J. and Lofts, B.(1956):** The leydig cell homologue in certain teleost fishes. Nature, London 177:704-705.

**Marte, C.L., Sherwood, N.M., Crim, L.W. and Harvey, B. (1987):** Induced spawning of maturing milk fish (*Chanos chanos forsskal*) with gonadotropin-releasing hormone (Gn RH) analogues administered in various ways Aquaculture, 60:303-310 .

**Marte, C.L., Sherwood, N., Crim, L. and Tan, J. (1988):** Induced spawning of maturing milk fish (*Chanos chanos*) using Human chorionic gonadotropin and mammalian and salmon gonadotropin releasing hormone analogues. Aquaculture, 73:333-340.

**Mathews, S.A.( 1938):** The seasonal cycle in the gonads of *Fundulus*. Biological Bulletin, Marine Biological Laboratory, Woods. Hole, Mass. 74:66-74.



**Mollah, M.F.A and Tan, E.S.P. (1983):** HCG. Induced spawning of the catfish, *Clarias macrocephalus* (Gunther). *Aquaculture* 35 : 239- 247 .

**Mono, Y. and Lipmann, F. (1966):** Characteristics of phosphoprotein (phosvitins) from a variety of fish roes. *Journal of Biological Chemistry* 241:3822-3833.

**Morrill, G.A., Schatr, Kostellow, A.B. and Poupka, J.M. (1977):** Changes in cyclic AMP levels in the amphibian ovarian follicle, progesterone induction of meiotic maturation. *Differentiation*, 8: 97-104.

**Moser, H.G. (1967):** Seasonal histological changes in the gonads of *Sebastes paucispinis* (Ayers), an ovoviviparous teleost (Family Scorpaenidae). *Journal of Morphology* 123: 329- 354.

**Nagahama, Y., Hirose, K., Young, G.A., Dachia, S., Suzuk, K. and Tamaoki, B.I. (1983):** Relative in vitro effectiveness of 17  $\alpha$ , 20  $\beta$  - dihydroxy - 4- pregnen - 3 - one and other pregnen derivatives on germinal vesicle breakdown in oocyte of Ayu (*Plecoglossus altivalis*) Amago salmon (*Oncorhynchus rhodurus*) Rainbow trout. *Gen. Comp. Endocrinol.*, 51 : 15- 23

- Nemetallah, B. R. and Ahamed, I. I. (1987):** Contractile activity of *Oreochromis niloticus* in spawning and non spawning fish in vitro. J. Egyptian Vet. Med. Ass. 47 : 1439 .
- Nicholls, T.J. and Maple, G. (1972):** Ultrastructural observation on possible sites of steroid biosynthesis in the ovarian follicular epithelium of two species of Cichlid fish, *Cichlasoma nigrofasciatum* and *Haplochromis multicolor*. Zeitschrift für Zellforschung und mikroskopische Anatomie 128: 317- 335.
- Norrevang, A. (1968):** Electron microscopic morphology of oogenesis. International Review of Cytology 23: 113-186.
- Pandy, S. (1969):** Effects of hypophysectomy on the testis and secondary sex characters of a dult guppy *Poecilia reticulata* (peters) Canadian Journal of Zoolgy 74:775- 781.
- Pankhurst, N.W., Van der Hraak , G. and Peter, R.E. (1986) :** Effect of human chorionic gonadotropin, Des- Gly<sup>10</sup> ( D-Ala<sup>6</sup> ) LHRH- ethylamide and pimozide on oocyte final maturation, ovulation and levels of plasma sex steroids in the Walleye (*Stizostedion vitreum* ) Fish Physiol . Biochem. 1 : 45 – 54 .
- Piper, R.G., Huner, J.V. and Lamv, W.S. (1989):** Fish hatchery management. United States Departement of Interior ,Fish and Wild life Service .

---

**Plack, P.A., Pritchard, D.J. and Fraser, N.W. (1971):** Egg protein in cod serum. Natural occurrence and induction by injection of oestradiol 3.benzoate. *Biochemical Journal* 121:847- 856 .

**Polder, J.J.W.(1961):** Cyclic changes in testis and ovary related to maturity stages in the North sea herring *Clupea harengus*l. *Archives Neerlandaises de Zoologie* 14:45- 60.

**Resink, J.W., Schoonen, W.G.E.J., VanDen Hurk, R., Viveen, W.J.A.R. and Lambert, J.G.D.(1987<sub>a</sub>):** Seasonal changes in steroid metabolism in male reproductive organ system of the African catfish, *Clarias gariepinus* . *Aquaculture*, 63 : 59 – 76 .

**Resink, J.W., VanDenHurk , R., Voorthuis P.K, Terlouw, M., Deleeuw , R. and Viveen W. J. A. R.(1987<sub>b</sub>):** Quantitative enzyme histochemistry of steroid and glucuronide synthesis in testes and seminal vesicle, and its correlation to plasma gonadotropin level in *Clarias gariepinus* . *Aquaculture* , 63: 97-114 .

**Richter, C.J.J. and Van Den Hurk , R. (1982):** Effect of 11-desoxycorticosterone acetate and carp pituitary suspension on follicle maturation in the ovaries of African catfish, *Clarias lazera* (C.&V.)*Aquaculture*, 29:53- 66.

**Ruby, S.M. and McMillan, D.B.(1975):** The interstitial origin of germinal cells in the testes of Sticklebak. *Journal of Morphology* 145:295- 318.

---

**SAS.(1987)** : Statistical Analysis Guide, SAS Institute Inc. Cary, N. C., USA.

**Schoonen, W.G.E.J., Van Bennekum, A.M., Lambert, J.G.D., Viveen, W.J.A.R. and Van Oordt, P. G. W.J. (1987):** Steriodogenesis in Pre-and postspawned ovaries of feral African Catfish *Clarias gariepinus*. *Aquaculture* , 63 : 129 – 142.

**Shehadeh, Z. H. and Ellis , J.N.(1970):** Induced spawning of striped mullet (*Mugil cephalus* L.). *J. Fish Biol.* , 2 : 355-360 .

**Shehadeh, Z.H, Kuo, C. M . and Milisen , K.K. (1973):** Induced spawning of grey mullet (*Mugil cephalus* L.) with fractionated salmon pituitary extract .*J. Fish Biol*, 5 : 471 – 778 .

**Slater, C.H., Schreck, C.B. and Amend, D.F.(1994):** GnRHa injection accelerates final maturation and ovulation/spermiation of sockeye salmon (*Oncorhynchus nerka*) in both fresh and saltwater. *Aquaculture*, 130:279- 285.

**Staff,F.(1983):**Fish culture manual. Alaska Department of Fish and Game, Division of Fisheries Rehabilitation, Enhancement and Development .

**Stanley.H., Chieffi, G. and Botte, V. (1965):** Histological and histochemical observation on the testis of *Gobius paganellus*. *Zeitschrift fur Zellforschung und mikroskopische Anatomie* 65:350-362.

- Sundararaj, B.I. and Goswami, S.V.(1966):** Effects of mammalian hypophysial hormones , placental gonadotropin , gonadal hormones and adrenal corticosteriod on ovulation and spawning in hypophysectomized catfish, *Heteropneustes fossilis* (Bloch ) . J. Exp. Zool . 161: 287- 296.
- Sundararaj, B.I. and Goswami, S.V.(1977):** Hormonal regulation of in vivo and in vitro oocyte maturation in the catfish, *Heteropneustes fossilis* ( Bloch ) Gen. Comp. Endocrinol., 32: 17 – 28 .
- Tang, Y.A.(1964 ):** Induced spawning of Striped mullet by hormone injection. Jpn. J. Ichthyol., 12(1/2):23 – 28.
- Teugles, G.G.(1982):** Asystematic outline of the African species of the genus *Clarias* ( pisces : Clariidae ) with an annotated bibliography. Ann. Mus. R. Afr. Centr. Ser. 8, Sci. Zool., 236-249.
- Tokarz, R.R.(1978):** Oogonial proliferation, oogenesis and folliculogenesis in non mammalian vertebrates. In. Jones RE (ed). The ovary . Plenum Press., New York , 28 ch<sub>4</sub>, p 145-179.
- Tseng, L.C. and Hsiao , S.M.(1979):** First successful case of artificial propagation of pond – reared milkfish. China Fish .,320: 9 – 10 ( in Chinese )

*Upodhyay, S.N., Breton B. and Billard, R.(1978):* Ultrastructural studies on experimentally induced vitellogenesis in Juvenile rainbow trout ( *salmo gairdneri* R.) *Annales de Biologie Animale, Biochimie et Biophysique.* 18 : 1019- 1025.

*Van Den Hurk,R. and Peute, J.(1985):* Functional aspects of postovulatory follicles in the ovary of the African catfish, *Clarias gariepinus* after induced ovulation. An ultrastructural and enzyme-histochemical study. *Cell Tissue Res.*, 240:199-208 .

*Van Der Wall, B.C. W.(1978):* Some breeding and production experiments with *Clarias gariepinus* (Burrhell) in the transvaal. *S. Afr. J. Wild. Res.* 8: 13-17.

*Van Der Wall , B.C.W. (1985):* Stripping male *Clarias gariepinus* of semen. *Aquaculture.* 48: 137 – 142 .

*Van Oordt, P.G. W.J., peute, J., Van DenHur k, R. and Viveen, W.J.A.R.(1987):* Annual correlative changes in gonads and pituitary gonadotropes of feral African catfish, *Clarias gariepinus*. *Aquaculture*, 63:27- 41.

*Van Ree , G. E., Lok, D. and Bosman, G.(1977):* In vitro induction of nuclear breakdown in oocyte of Zebrafish, *Brachydanio rerio* ( Ham-Buch ). Effect of the composition of the medium and of protein and steroid hormones . *Proc. K. Ned. Akad. Wet., Ser. C*, 80 : 353-371.

**References**

- Vanstone, W.E., Tiro, L.B., Jr., Villaluz, A.C., Barnes, D.C. and Duenas, C.E. (1977):** Breeding and larval rearing of milkfish, *Chanos chanos* (Pisces : chanidae). SEAFDEC. Aquaculture Department. Tech. Rep., 3 : 3-17.
- Wallace, R.A. (1978):** Oocyte growth in non mammalian vertebrates . In : Jones RE ( ed ). The Vertebrate Ovary . Plenum Press , New York , p 469 – 502.
- Wourms, J.P.(1976):** Annual fish oogenesis .I. Differentiation of the mature oocyte and formation of primary envelope . *Developmental Biology* 50 : 338 – 354 .
- Wourms, J.P. and Sheldon, H. (1976):** Annual fish oogenesis II . Formation of the secondary egg envelope . *Developmental Biology* 50 : 355 – 366 .
- Yamazaki, F. (1976):** Application of hormones in fish culture . *J.Fish Res.Board Can.* 33:948-958.
- Yamazaki, F. and Donaldson , E.M. (1968 ):** The effect of partially purified Salmon pituitary gonodotropin on spermatogenesis, vitellogenesis and ovulation in hypophysectomised goldfish *Carassius auratus* . *General and Comparative Endocriology* II : 292 –299 .
- Yashouv, A., Berner–Samsonov, E. and Karamosta, K. (1969):** Preliminary report on induced spawning of *M. cephalus* (L.) reared in captivity in freshwater ponds. *Bamidgeh*, 21: 19-24.

---

# **ARABIC SUMMARY**



## الملخص العربي

- تعتبر برامج تربية أسماك القرموط وكذلك صعوبة الحصول على زريعة من أهم المشاكل التي تواجه الاستزراع السمكي لتلك النوعية من الاسماك على النطاق الاقتصادي لإنتاج أعداد كبيرة من الزريعة وكذلك فإن تلك المشاكل :
- 1-الحصول على السائل المنوي بكمية كافية من الخصية.
  - 2-بيض تلك الأسماك مغطى بطبقة لزجة مما يقلل من نسبة الفقس وعدم تعرض البيض لاي من المعاملات.
  - 3-تعفن البيض وعدم فقسه بعد عملية التحضين.
- ولهذا فقد تم إجراء هذه الدراسة لبحث كيفية حل هذه المشاكل والحصول على أعلى معدل لإنتاج الزريعة لهذا النوع من الأسماك. وشملت الدراسة أيضا تأثير بعض الهرمونات على درجة نضج البيض خارج الجسم وتحديد أفضلها.

### التجربة الأولى:

تم استخدام تسعون من إناث القراميط للحصول على المبيض بعد تحديد الوزن لأقرب جرام ثم استخدم جزئين من مبيض كل سمكة. ولإجراء التجربة عومل الجزء الأول بغمسه في محلول موضح لتحديد درجة نضج البيض والجزء الثاني استخدم لدراسة تأثير

الهرمونات المختلفة حيث تمت معالجة البيض بانزيم ألفاكيوتربسين (5 ملليجرام/100 سم ماء فقط لمدة خمسة دقائق) وذلك لإزالة المادة اللزجة وعدم التصاق البيض حيث تم تحضين البيض مع هرمون الجونادوتروبين المشيمي البشري لمدة 6 ساعات في محلول ايرليز وقسم البيض إلى تسعة مجموعات كل مجموعة حضنت لمدة 42 ساعة في محلول ايرليز مع أحد الهرمونات الآتية:-

- |  |    |
|--|----|
| $\Delta^5$ - pregnen-3 $\beta$ -ol-20 one            | -1 |
| Androstenedione                                      | -2 |
| 5 $\beta$ -androstane – 3, 17dione                   | -3 |
| 4-pregnen-20 $\beta$ -ol-3-one                       | -4 |
| Testosterone   | -5 |
| Dehydroandroestrone                                  | -6 |
| 5-hydroxy-tryptamine (seratonin)                     | -7 |
| 5 $\alpha$ -androstan –17 $\beta$ -ol-3-one          | -8 |
| 5 $\alpha$ -pregnane –3 $\beta$ -, 20 $\alpha$ -diol | -9 |

حيث تم استخدام ثلاث تركيزات من كل هرمون (1، 2، 3 ميكروجرام) لكل واحد

ملليمتر من محلول ايرليز بعد مرور فترة التحضين مع مختلف الهرمونات وضع البيض في

محلول التوضيح وفحص بواسطة الميكروسكوب التشريحي لتحديد درجة نضج البيض في كل

مجموعة.

#### وأوضحت النتائج مايلي:-

\* عند استخدام الهرمونات  $\Delta^5$  - pregnen-3 $\beta$ -ol-20 one (3 $\mu$ g/ml) و

5 $\beta$ -androstane - 3, 17dione (1  $\mu$ g/ml) and 4-pregnen-20 $\beta$ -ol-3-one (2  $\mu$ g/ml).

أدت تلك الهرمونات بهذه التركيزات إلى زيادة معنوية في حجم ونضج البيض .

#### • كما أن استخدام الهرمونات :-

$\Delta^5$  - pregnen-3 $\beta$ -ol-20 one (3 $\mu$ g/ml), testosterone (3  $\mu$ g/ml) & 5 $\alpha$ -androstan -17 $\beta$ -ol-3-one (2  $\mu$ g/ml) & 5  $\alpha$ -pregnane -3 $\beta$ -, 20 $\alpha$ -diol (1  $\mu$ g/ml).

أدت الى زيادة غير معنوية في نضج البيض.

وعند استخدام هرمونات:-

HCG (100 I.U/ml),  $\Delta^5$  - pregnen-3 $\beta$ -ol-20-one (1 $\mu$ g/ml), androstenedione (1 or 2 or 3  $\mu$ g/ml), 5 $\beta$ -androstane - 3, 17dione (1 or 3  $\mu$ g/ml), testosterone ( 1 or 2  $\mu$ g/ml), dehydroisoandroesterone (1 or 2 or 3  $\mu$ g/ml), serotonin ( 1 or 2 or 3  $\mu$ g/ml), 5  $\alpha$ -pregnane - 3 $\beta$ -. 20 $\alpha$ -diol (2 or 3 $\mu$ g/ml), 5  $\alpha$ -androstan -17 $\beta$ -ol-3-one (1 or 3  $\mu$ g/ml).

لم يلاحظ أى تأثير لها على نضج البيض.

### التجربة الثانية:-

تم استخدام خمسون من ذكور القراميط وكذلك خمسون من الإناث حيث تم حقنها فى العضل بمستحلب الغدة النخامية لسماك المبروك (C.P.h). وبعد مرور فترة من 18-21 ساعة من بداية الحقن فحصت الإناث لاختبار التبويض بتدليك البطن حيث أن خروج البيض من الفتحة التناسلية للسكة باللون البنى المخضر دليل على حدوث التبويض وفى الحال وقبل الحصول على البيض من إناث القراميط بتدليك البطن تم ذبح ذكور القراميط والحصول على الخصية وعصرها فى محلول ملحي 0.9% وبعد ذلك تم تجميع البيض فى أطباق بترى ثم وزع المحلول الذى يحتوى على الحيوانات المنوية على البيض وقلب المحلول و البيض برفق لحدوث التخصيب وبعد ذلك نقل البيض المخصب وحضن فى Zug-Jar فى درجة حرارة الغرفة ( $25 \pm 1$  م °) حيث تم معالجة البيض بإنزيم ألفاكيومتريسين لإزالة المادة اللزجة من على البيض لمنع التصاقه وعدم إعاقة قعر البيض.

### أوضحت نتائج التجربة مايلى:-

- 1- حقن مستحلب الغدة النخامية لسماك المبروك C.P.h من إناث القراميط أدى إلى نضوج البيض و حدوث التبويض فى كل من الأسماك المحقونة. كما أدى إلى زيادة حجم الخصية فى الذكور وزيادة كمية السائل المنوى بها.
- 2- بعد عملية التلقيح وتحضين البيض لعشرة ساعات وجد أن البيض وصل إلى مرحلة Monila ، وبعد 24 ساعة من تحضين البيض وجد أن نسبة الفقس  $91.88 \pm 7.4$  وبعد 48 ساعة وجدت نسبة اليرقات الضعيفة  $87 \pm 3.1$  وأن نسبة اليرقات الغير طبيعية  $12 \pm 10.4$  .

ويستخلص من النتائج السابقة مايلى :-

1- أكثر الهرمونات المخلفة تأثيرا فى إحداث نضج البيض فى أسماك القراميط خارج

الجسم هي:-

$\Delta^5$  - pregnen-3 $\beta$ -ol-20-one (3 $\mu$ g/ml), 5 $\beta$ -androstane - 3, 17dione (1  $\mu$ g/ml), 4-pregnen-20 $\beta$ -ol-3-one (2 $\mu$ g/ml).

2) مستحلب الغدة النخامية لأسماك المبروك C.P.h أدى إلى نضج (إناث وذكور) أسماك

القراميط مما يشجع على استخدامه بدلا من المعالجات الأخرى نظرا لتوفره وسهولة الحصول عليه.

3) أن أنزيم Alphachymotrypsin أزال المادة اللزجة الموجودة على الجدار الخارجى لبيض القراميط. مما ساعد على حل المشاكل المترتبة على التصاق البيض أثناء عملية التفريخ والتي تمنع فقس البيض. و أيضا إزالة هذه المادة ساعد على تأثير الهرمونات المستخدمة لإحداث النضج خارج جسم السمكة مما يشجع على استخدام هذا الإنزيم بدلا من الأنزيمات الأخرى المستخدمة المعروفة بأنها باهظة الثمن وغير متوفرة للمربي العادى.

## تحت إشراف

الأستاذ الدكتور

**بهيح رياض نعمة الله**

أستاذ الفسيولوجيا

كلية الطب البيطرى - جامع الاسكندرية

الأستاذ الدكتور

**سمير عبد المجيد غنام**

استاذ الفسيولوجيا

كلية الطب البيطرى - جامعة الاسكندرية

دكتور

**صبحى عبد العزيز حداية**

أستاذ الفسيولوجيا المساعد

كلية الطب البيطرى - جامعة الإسكندرية

دكتور

**محيى الدين محمد عبد الله**

استاذ الفسيولوجيا المساعد

كلية الطب البيطرى - جامعة الإسكندرية



٥٦٥

# إحداث التفريخ فى القرموط الأفريقي

( كلارياس لازيرا ) بواسطة الهرمونات

رسالة مقدمة من

السيد ط.ب/ إسماعيل إسماعيل يوسف أبو غنيمة

بكالوريوس العلوم الطبية البيطرية - جامعة الإسكندرية ( ١٩٩٤ )

للحصول على

درجة الماجستير فى العلوم الطبية البيطرية

( فسيولوجيا الحيوان )

مقدمة إلى

كلية الطب البيطري - جامعة الإسكندرية

١٩٩٩