

COMPONENTS OF VARIABILITY IN BITUMINOUS
CONCRETE PAVEMENT CONSTRUCTION

By

BEDII BELGAROUİ

Bachelor of Science

Oklahoma State University

Stillwater, Oklahoma

1990

Submitted to the Faculty of the
Graduate College of the
Oklahoma State University
in partial fulfillment of
the requirements for
the Degree of
MASTER OF SCIENCE
May, 1992

thesis
1992
B429c

COMPONENTS OF VARIABILITY IN BITUMINOUS
CONCRETE PAVEMENT CONSTRUCTION

Thesis Approved:

Samin Ahmed

Thesis Advisor

Ganesh D. Balakrishna

M. K. Chy

Thomas C. Collins

Dean of the Graduate College

ACKNOWLEDGEMENTS

I wish to express my deep sense of gratitude to Dr. S. A. Ahmed for supervising the work. I am deeply indebted to him for building my interest in this field, his inspiring guidance, meticulous attention, and untiring devotion throughout the tenure of this work. I would not have achieved my goal without him. I am also thankful to Dr. M. Ayers and Dr. G. Oberlender for serving on my graduate committee. My thanks also go to Dr. M. Oner for helping me solve some of the problems I encountered during this work.

I would like to express my deepest and sincere love to my father and mother, Abdallah and Fatma, my brother Amor, and my sisters, Ibtissem, Taweded, and Imen for their continuous love, support, and encouragement throughout my life. I dedicate this work to all of them.

Finally, I wish to thank all my friends in Stillwater and in Tunisia for helping me, each in his own way, and for giving me the moral support I needed. Without you, my friends, my life would have been meaningless. I wish you the best.

GOD ALMIGHTY, please forgive me.

TABLE OF CONTENTS

Chapter	Page
I. INTRODUCTION	1
Components of Variability in Highway Products.	4
Material Variation.	4
Sampling Variation.	4
Testing Variation	5
Analysis of Variance.	5
Objectives and Scope	6
Overview of the Next Chapters	8
II. THE COMPLETE BALANCED THREE-FACTOR NESTED DESIGN ...	9
Sums of Squares	10
Mean Squares	12
Expected Mean Squares	12
Between Tests Expected Mean Squares	13
Between Sample units Expected Mean Squares.	15
Between Sublots Expected Mean Squares.	16
Hypothesis Testing and Use of the F-ratio.	20
Test for subplot-to-sublot variation	20
Test for sample unit-to-sample unit variation	22
Some Remarks Concerning F-ratios	
That are Less Than Unity.	22
A Numerical Example	23
Computational Formulas	23
III. HOW TO USE "NANOVA".....	28
The Code Structure	28
Getting Started	32
Summary of Procedures.	33
Data Management.	34
File Management	36
Summary Statistics	37
Nested ANOVA	40

Chapter	Page
IV. APPLICATION.....	42
Mixture Analysis.....	43
Material Variation.....	43
Sampling Variation.....	64
Testing Variation.....	65
Aggregate Analysis.....	67
Material Variation.....	67
Sampling Variation.....	68
Testing Variation.....	68
Summary.....	69
Aggregate Analysis.....	69
Mixture Analysis.....	70
Aggregate Analysis Versus Mixture Analysis.....	70
V. CONCLUSIONS.....	71
Aggregate Analysis.....	71
Mixture Analysis.....	72
Aggregate Analysis Versus Mixture Analysis.....	72
REFERENCES.....	74
APPENDIX A - TYPICAL STATISTICAL REPORTS PRODUCED BY NANOVA.....	76
APPENDIX B - NANOVA REPORTS FOR NESTED ANALYSIS OF VARIANCE.....	86

LIST OF TABLES

Table	page
1. Mathematical Notation	11
2. Axioms of Mathematical Expectations.	14
3. Analysis of Variance Table	21
4. Data for Material Passing 3/8 inch Sieve.	24
5. Analysis of Variance Table for Data From Table 4	26
6. NANOVA Files.	30
7. Saved Files and Their Corresponding Extensions.	34
8. Summary of Nested ANOVA Reports (Mixture Analysis).	44
9. Summary of Nested ANOVA Reports (Aggregate Analysis)	45
10. Summary of Descriptive Statistics Reports (Mixture Analysis)	46
11. Summary of Descriptive Statistics Reports (Aggregate Analysis).	47

LIST OF FIGURES

Figure	Page
1. Precision and Accuracy of Measurements	3
2. Sampling Plan For Nested ANOVA Experiment.	7
3. Flow Diagram for NANOVA.	29
4. Introductory Screen.	32
5. Main Menu.	32
6. Data Management.	35
7. Delete/Add Sublots.	36
8. File Management.	37
9. Summary Statistics	38
10. Frequency Distributions.	39
11. Percentiles.	39
12. Control Charts	41
13. Components of Variance, Mixture Analysis vs. Aggregate Analysis for Sieve 1".	48
14. Components of Variance, Mixture Analysis vs. Aggregate Analysis for Sieve 3/4"	49
15. Components of Variance, Mixture Analysis vs. Aggregate Analysis for Sieve 1/2"	50
16. Components of Variance, Mixture Analysis vs. Aggregate Analysis for Sieve 3/8"	51

Figure	Page
17. Components of Variance, Mixture Analysis vs. Aggregate Analysis for Sieve No. 4.	52
18. Components of Variance, Mixture Analysis vs. Aggregate Analysis for Sieve No. 10.	53
19. Components of Variance, Mixture Analysis vs. Aggregate Analysis for Sieve No. 40.	54
20. Components of Variance, Mixture Analysis vs. Aggregate Analysis for Sieve No. 80.	55
21. Components of Variance, Mixture Analysis vs. Aggregate Analysis for Sieve No. 200.	56
22. Mixture Analysis, Extracted vs. Nuclear % AC Measurements	57
23. Mixture Analysis, Core Density vs. Nuclear Density	58
24. Mixture Analysis, Average Rices.	59
25. Mixture Analysis, Average LMSG.	60
26. Mixture Analysis, % Air Voids.	61
27. Mixture Analysis, Average Stability.	62

CHAPTER I

INTRODUCTION

Measurements of the quality attributes of highway construction materials and products are needed for both process control and acceptance methods. Process control includes the activities which are carried out by the contractor or material supplier to control the product's or material's quality to some prescribed standard. Acceptance methods involve the sampling, testing, and inspection performed by the highway agency to determine the level of quality of what they are receiving compared to what they have contracted for.

A measurement is an *approximation* of the *true* or *exact* value of an unknown quality attribute. Since the true value cannot be measured by physical means, a measurement typically includes an inherent error. In the discussion of measurements and their associated errors, the terms *accuracy* and *precision* are often used.

Accuracy refers to the exactness within which a measured value represents the true value, i.e, its closeness to the true or accepted reference value. An accepted reference value is a value that serves as an agreed upon reference for comparison. It could be a theoretical value based on scientific principles or an assigned value based on experimental work [2].

Precision refers to the reproducibility of a measurement, i.e, the degree of

nearness of individual measurements to each other when these measurements are obtained under prescribed like conditions [2].

A group of measurements can be precise without being accurate, i.e, the results may be clustered near each other but bear no relationship to the true value.

Conversely, a group of measurements could be relatively accurate, in that their mean is very close to the true value, and yet the individual measurements be widely spread around this mean, indicating poor precision.

The relationship between accuracy and precision can be demonstrated by the example of three marksmen shooting at a target as depicted in Figure 1. The results of marksman A indicate good precision, but poor accuracy; the shots are spaced closely together near one spot some distance from the bull's eye. The distance from the bull's eye to the center of the marks is called the *bias*. Marksman B has good accuracy because the shots are well distributed around the bull's eye, but his precision is poor because the shots are widely scattered on the target. Marksman C has good precision and good accuracy, i.e, he has shown good accuracy without bias because the shots are closely grouped inside the bull's eye.

With reference to Figure 1, reliability of measurements can be explained by comparing marksman B and C. Both marksmen scored the same average, however marksman C has a better precision than marksman B. In terms of probability, marksman C is more likely to perform without failure than marksman B in terms of future performance. Therefore, the shootings of marksman C are said to be more reliable than those of marksman B. In general, reliability is an assessment of future performance. Reliability of measurements is a prediction of the accuracy and

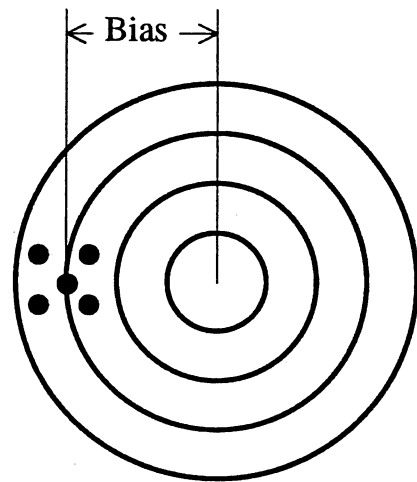

A

Poor Accuracy
Good Precision
(Average Off Center)

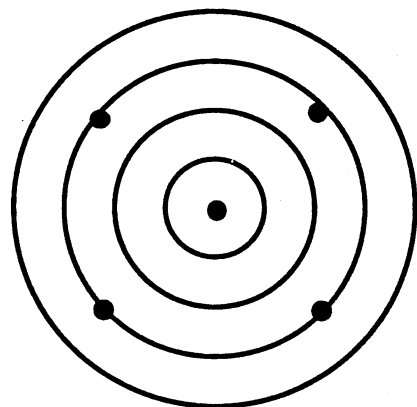

B

Good Accuracy
Poor Precision
(Average On Center)

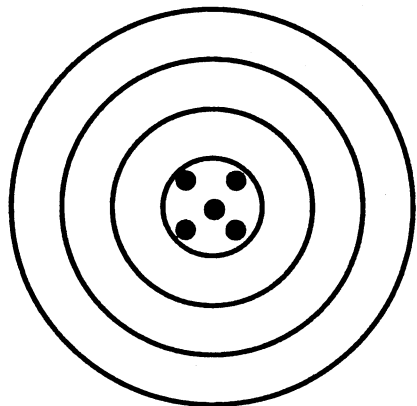

C

Good Accuracy
Good Precision
(Average On Center)

Figure 1. Precision and Accuracy of Measurements

precision of measurements to be taken in the future based on the accuracy and precision of measurements already taken.

Components of Variability in Highway Products

In quality assurance applications, it is useful to divide the total variability in the measured quality attribute of acceptable construction materials and products into three components: material variation, sampling variation, and testing variation. A brief discussion of the three components is given in the following sections.

Material Variation

This component represents the true random variation of the construction material and process. When samples are taken from several sublots and tests are performed on these samples, there will be differences in the averages of the test results for the different sublots no matter how carefully the samples are taken, handled and tested. The component of variance caused by this unavoidable lack of uniformity is denoted by σ_M^2 .

Sampling Variation.

Every sampling procedure has certain variability associated with it. Samples taken from the same subplot will differ due to segregation and other causes. The component of variance caused by the method of obtaining samples for testing is denoted by σ_s^2 .

Testing Variation.

Testing variation is a function of the precision of the test method; the repeatability of test results obtained in the same laboratory, by the same operator and test apparatus using test specimens that are nearly alike. In any test determination, variation exists in the measured values due the method of testing. The symbol σ_T^2 is used to denote this component of variance.

In drafting quality assurance specifications, the above components of variance should be taken into account in setting the allowable deviations from specified standards. The more serious deviations resulting from *assignable causes* in construction materials or processes can then be detected and penalized.

Analysis of Variance

An important theorem of mathematical statistics states that the variance of the sum of any number of independent factors that contribute to the overall variability is equal to the sum of the component variances of the individual factors. This property of the variance is the basis of an analytical technique, known as analysis of variance (ANOVA), which can be utilized to compute the variance of the component factors and to test the statistical significance of each factor.

Application of the ANOVA requires a well designed statistical experiment that permits analyzing the different factors involved in the experiment. Designing a statistical experiment simply means planning the experiment so that the information obtained will provide satisfactory answers to the questions that prompted the study

without doing unnecessary work. A nested design is a form of statistical experiments which is useful in characterizing product variation and determining the contribution of each source of variability. In such a design, levels of a second factor are nested within levels of the main factor, and levels of a third factor are nested within levels of the second factor. Nesting can be continued to involve any desired number of factors.

Figure 2 illustrates a sampling plan for a nested design involving three sources of variation (factors) in measurements of some quality attribute of a lot of highway material or construction. The lot is divided into l different sublots of equal sizes and s duplicate sample units are obtained from each subplot. Each sample unit is then split into t test portions. In this design, factor L (sublots) contains l levels. There are s levels of factor S (sample units) nested within each level of factor L and t levels of factor T (test specimens) nested within each level of factor S . Because the same number of sample units is taken from each subplot, and each sample unit is divided into the same number of test specimens, the design is referred to as *completely nested* or *balanced* design.

Objectives and Scope

The main objective of this research was to develop a computer program "NANOVA" that performs the necessary analysis of variance computations for a complete three-factor nested design. Program NANOVA can be used to determine the components of variance due to materials, due to sampling, and due to testing in the measured quality attributes of construction materials and products. In addition, it has

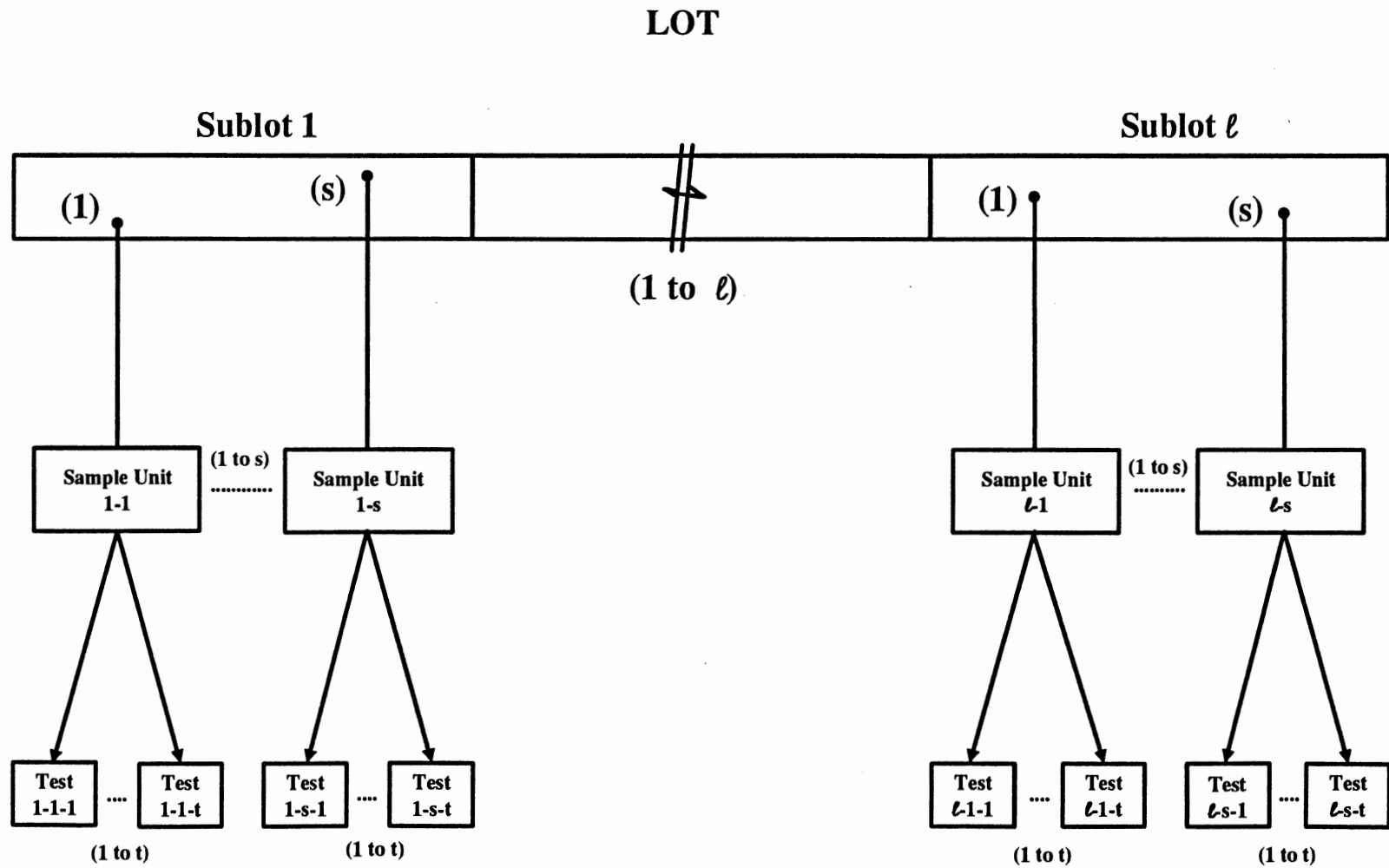

Figure 2. Sampling Plan For Nested ANOVA Experiment

the capability of describing and presenting data that have been collected on a particular quality attribute using numerical, tabular, and graphical methods. Program NANOVA was applied to data obtained from project No. MAF-398(82), highway US-412, Delaware County, OK, to determine the components of variance in the measured quality attributes of type-F asphalt concrete mix.

Overview of the Next Chapters

Chapter II of this thesis presents the theory and the derivation of mathematical formulas for a complete three-factor nested statistical design. Chapter III describes the basic components of the developed computer program (NANOVA) and its use to obtain the desired statistical results. Application of program NANOVA to data obtained from project No. MAF-398(82), highway US-412, Delaware County, OK, is provided in chapter IV. The conclusions of this study are summarized in chapter V.

CHAPTER II

THE COMPLETE THREE-FACTOR NESTED DESIGN

Consider a statistical experiment with three factors, T , S , and L , where T is nested within S , and S is nested within L . With reference to Figure 2, L represents sublots of bituminous concrete pavement, S represents sample units taken at random from the sublots, and T represents tests performed on specimens prepared from the sample units. It is further assumed that factor L has l levels, factor S has s levels, and factor T has t levels.

Let y_{ijk} be a measurement made on test specimen k , taken from sample unit j in subplot i . The measurement y_{ijk} may be expressed as follows:

$$y_{ijk} = \mu + L_i + S_{ij} + T_{ijk} \quad (1)$$

where:

μ = overall population mean, i.e, mean of the lot;

L_i = effect of material and construction processes used to produce the i th subplot ($i = 1, \dots, l$);

S_{ij} = effect of sampling technique used to obtain the j th sample unit from the i th subplot ($j = 1, \dots, s$);

T_{ijk} = effect of test method on measuring a property of the k th test

specimen taken from the j th sample unit in the i th subplot ($k = 1, \dots, t$).

In addition, it is assumed that L_i , S_{ij} , and T_{ijk} are independent, normally distributed variables with zero means and variances of σ_M^2 , σ_S^2 , and σ_T^2 , respectively.

Sums of Squares

The model presented in equation 1 involves three different sums of squares: *the between tests sum of squares* (SS_T), *the between sample units sum of squares* (SS_S), and *the between sublots sum of squares* (SS_L). These sum of squares are given by the following equations:

$$SS_T = \sum_{i=1}^l \sum_{j=1}^s \sum_{k=1}^t (y_{ijk} - y_{ij.})^2 \quad (2)$$

$$SS_S = \sum_{i=1}^l \sum_{j=1}^s \sum_{k=1}^t (y_{ij.} - y_{i..})^2 \quad (3)$$

$$SS_L = \sum_{i=1}^l \sum_{j=1}^s \sum_{k=1}^t (y_{i..} - y_{...})^2 \quad (4)$$

Table 1 describes the mathematical notation used in the above equations. Since sums of squares are additive we can express the total sum of squares (SS_{Total}) as the sum of SS_L , SS_S and SS_T , that is,

$$\sum_{i=1}^l \sum_{j=1}^s \sum_{k=1}^t (y_{ijk} - y_{...})^2 = SS_{Total} = SS_L + SS_S + SS_T \quad (5)$$

TABLE 1
MATHEMATICAL NOTATION

$$y_{ij.} = \frac{1}{t} \sum_{k=1}^t y_{ijk}$$

$$y_{i..} = \frac{1}{st} \sum_{j=1}^s \sum_{k=1}^t y_{ijk}$$

$$y_{...} = \frac{1}{lst} \sum_{i=1}^l \sum_{j=1}^s \sum_{k=1}^t y_{ijk}$$

where:

$y_{ij.}$ = mean value of an attribute of the test specimens in the j th sample unit which is taken at random from subplot i ;

$y_{i..}$ = mean value of an attribute of the sample units in the i th subplot;

$y_{...}$ = mean of the subplot means (or grand mean of an attribute of a lot);

$y_{ijk} - y_{ij.}$ = the deviation of the measurement y_{ijk} from the j th sample unit mean;

$y_{ij.} - y_{i..}$ = the deviation of the j th sample unit mean from the i th subplot mean;

$y_{i..} - y_{...}$ = the deviation of the i th subplot mean from the grand mean.

Mean Squares

To be useful in the analysis of variance, the above sums of squares must be converted to mean squares (or variances). In this context, a mean square (MS) is defined by the equation:

$$MS = \frac{SS}{df} \quad (6)$$

where SS refers to the sum of squares and df represents the degrees of freedom associated with the SS .

The degrees of freedom associated with a sum of squares is the number of measurements with independent information which enter into the calculation of the sum of squares [13, 19]. The general rule for computing the df of any sum of squares is:

$$df = N - P \quad (7)$$

where N is the number of independent measurements and P is the number of population parameters estimated using the measurements. For instance, there are l measurements associated with SS_L , i.e., l different subplot means ($y_{i..}$'s). Since one population parameter ($\mu_{...}$) is required to compute SS_L , as shown by equation 4, the corresponding degrees of freedom are $(l - 1)$. Similarly, the degrees of freedom associated with SS_S and SS_T are $l(s - 1)$ and $ls(t - 1)$, respectively.

Expected Mean Squares

The estimation of the three components of variance σ_M^2 , σ_S^2 , and σ_T^2 requires

the development of the expected values of the mean squares: $E[MS_T]$, $E[MS_S]$ and $E[MS_L]$. Table 2 provides axioms of mathematical expectations which are used in the derivation of the different expected mean squares. The following subsections summarize these derivations.

Between Tests Expected Mean Square

$$\begin{aligned} E[MS_T] &= E\left[\frac{SS_T}{df_T}\right] = E\left[\frac{1}{ls(t-1)} \sum_{i=1}^l \sum_{j=1}^s \sum_{k=1}^t (y_{ijk} - y_{ij.})^2\right] \\ &= \frac{1}{ls(t-1)} \sum_{i=1}^l \sum_{j=1}^s \sum_{k=1}^t E[(y_{ijk} - y_{ij.})^2] \end{aligned}$$

where,

$$\begin{aligned} y_{ijk} - y_{ij.} &= (\mu + L_i + S_{ij} + T_{ijk}) - \frac{1}{t} \left(\sum_{k=1}^t \mu + \sum_{k=1}^t L_i + \sum_{k=1}^t S_{ij} + \sum_{k=1}^t T_{ijk} \right) \\ &= (\mu + L_i + S_{ij} + T_{ijk}) - \frac{1}{t} \left(t\mu + tL_i + tS_{ij} + \sum_{k=1}^t T_{ijk} \right) \\ &= T_{ijk} - \frac{1}{t} \sum_{k=1}^t T_{ijk} \end{aligned}$$

Since T_{ijk} 's are independent random variables with zero means ($E(T_{ijk}) = 0$), their covariance is zero. So,

$$\begin{aligned} E[(y_{ijk} - y_{ij.})^2] &= E\left[\left(T_{ijk} - \frac{1}{t} \sum_{k=1}^t T_{ijk}\right)^2\right] = E[(T_{ijk})^2] - E\left[\left(\frac{1}{t} \sum_{k=1}^t T_{ijk}\right)^2\right] \\ &= \sigma_T^2 - \frac{1}{t^2} E\left[\left((T_{ij1} + \dots + T_{ijt})^2\right)\right] \\ &= \sigma_T^2 - \frac{1}{t^2} \left(E[(T_{ij1})^2] + \dots + E[(T_{ijt})^2] \right) \end{aligned}$$

TABLE 2

AXIOMS OF MATHEMATICAL EXPECTATIONS

If X_i is an independent, normally distributed random variable with zero mean and variance of σ_i^2 , and a_i is a constant, then:

$$E(a_i) = a_i$$

$$E(X_i) = 0$$

$$E(X_1 X_2) = E(X_1)E(X_2) = 0$$

$$V(a_i) = 0$$

$$V(X_i) = E(X_i^2) - [E(X_i)]^2 = E(X_i^2) = \sigma_i^2$$

$$V\left(\sum a_i X_i\right) = \sum a_i^2 V(X_i) = \sum a_i^2 \sigma_i^2$$

$$\text{Cov}(X_1, X_2) = E(XY) - E(X_1)E(X_2) = 0$$

$$= \sigma_T^2 - \frac{1}{t^2}(t\sigma_T^2) = \sigma_T^2 - \frac{\sigma_T^2}{t} = \frac{(t-1)}{t}\sigma_T^2$$

therefore,

$$E[MS_T] = \frac{1}{ls(t-1)} \sum_{i=1}^l \sum_{j=1}^s \sum_{k=1}^t \left(\frac{(t-1)}{t} \sigma_T^2 \right) = \frac{lst}{ls(t-1)} \left(\frac{t-1}{t} \right) \sigma_T^2 = \sigma_T^2$$

Between Sample units Expected Mean Square

$$\begin{aligned} E[MS_S] &= E \left[\frac{SS_S}{df_S} \right] = E \left[\frac{1}{l(s-1)} \sum_{i=1}^l \sum_{j=1}^s \sum_{k=1}^t (y_{ij.} - y_{i..})^2 \right] \\ &= \frac{1}{l(s-1)} \sum_{i=1}^l \sum_{j=1}^s \sum_{k=1}^t E[(y_{ij.} - y_{i..})^2] \end{aligned}$$

where,

$$\begin{aligned} y_{ij.} - y_{i..} &= \frac{1}{t} \left(\sum_{k=1}^t \mu + \sum_{k=1}^t L_i + \sum_{k=1}^t S_{ij} + \sum_{k=1}^t T_{ijk} \right) \\ &\quad - \frac{1}{st} \left(\sum_{j=1}^s \sum_{k=1}^t \mu + \sum_{j=1}^s \sum_{k=1}^t L_i + \sum_{j=1}^s \sum_{k=1}^t S_{ij} + \sum_{j=1}^s \sum_{k=1}^t T_{ijk} \right) \\ &= \frac{1}{t} \left(t\mu + tL_i + tS_{ij} + \sum_{k=1}^t T_{ijk} \right) \\ &\quad - \frac{1}{st} \left(st\mu + stL_i + t \sum_{j=1}^s S_{ij} + \sum_{j=1}^s \sum_{k=1}^t T_{ijk} \right) \\ &= \left(S_{ij} - \frac{1}{s} \sum_{j=1}^s S_{ij} \right) + \left(\frac{1}{t} \sum_{k=1}^t T_{ijk} - \frac{1}{st} \sum_{j=1}^s \sum_{k=1}^t T_{ijk} \right) \end{aligned}$$

so,

$$\begin{aligned}
 E[(y_{ij.} - y_{i..})^2] &= E\left[\left(\left(S_{ij} - \frac{1}{s} \sum_{j=1}^s S_{ij}\right) + \left(\frac{1}{t} \sum_{k=1}^t T_{ijk} - \frac{1}{st} \sum_{j=1}^s \sum_{k=1}^t T_{ijk}\right)\right)^2\right] \\
 &= E[(S_{ij})^2] - E\left[\left(\frac{1}{s} \sum_{j=1}^s S_{ij}\right)^2\right] \\
 &\quad + E\left[\left(\frac{1}{t} \sum_{k=1}^t T_{ijk}\right)^2\right] - E\left[\left(\frac{1}{st} \sum_{j=1}^s \sum_{k=1}^t T_{ijk}\right)^2\right] \\
 &= \sigma_s^2 - \frac{s\sigma_s^2}{s^2} + \frac{t\sigma_T^2}{t^2} - \frac{st\sigma_T^2}{s^2t^2} \\
 &= \sigma_s^2 - \frac{\sigma_s^2}{s} + \frac{\sigma_T^2}{t} - \frac{\sigma_T^2}{st} = \left(\frac{s-1}{s}\right)\sigma_s^2 + \left(\frac{s-1}{st}\right)\sigma_T^2
 \end{aligned}$$

therefore,

$$\begin{aligned}
 E[MS_s] &= \frac{1}{l(s-1)} \sum_{i=1}^l \sum_{j=1}^s \sum_{k=1}^t \left(\left(\frac{s-1}{s}\right)\sigma_s^2 + \left(\frac{s-1}{st}\right)\sigma_T^2 \right) \\
 &= \frac{lst}{l(s-1)} \left(\frac{s-1}{s}\right)\sigma_s^2 + \frac{lst}{l(s-1)} \left(\frac{s-1}{st}\right)\sigma_T^2 \\
 &= t\sigma_s^2 + \sigma_T^2
 \end{aligned}$$

Between Sublots Expected Mean Square

$$\begin{aligned}
 E[MS_L] &= E\left[\frac{SS_L}{df_L}\right] \\
 &= E\left[\frac{1}{(l-1)} \sum_{i=1}^l \sum_{j=1}^s \sum_{k=1}^t (y_{i..} - y_{...})^2\right] \\
 &= \frac{1}{(l-1)} \sum_{i=1}^l \sum_{j=1}^s \sum_{k=1}^t E[(y_{i..} - y_{...})^2]
 \end{aligned}$$

where,

$$\begin{aligned}
y_{i...} - y_{...} &= \frac{1}{st} \left(\sum_{j=1}^s \sum_{k=1}^t \mu + \sum_{j=1}^s \sum_{k=1}^t L_i + \sum_{j=1}^s \sum_{k=1}^t S_{ij} + \sum_{j=1}^s \sum_{k=1}^t T_{ijk} \right) \\
&\quad - \frac{1}{lst} \left(\sum_{i=1}^l \sum_{j=1}^s \sum_{k=1}^t \mu + \sum_{i=1}^l \sum_{j=1}^s \sum_{k=1}^t L_i + \sum_{i=1}^l \sum_{j=1}^s \sum_{k=1}^t S_{ij} + \sum_{i=1}^l \sum_{j=1}^s \sum_{k=1}^t T_{ijk} \right) \\
&= \frac{1}{st} \left(st\mu + stL_i + t \sum_{j=1}^s S_{ij} + \sum_{j=1}^s \sum_{k=1}^t T_{ijk} \right) \\
&\quad - \frac{1}{lst} \left(lst\mu + st \sum_{i=1}^l L_i + t \sum_{i=1}^l \sum_{j=1}^s S_{ij} + \sum_{i=1}^l \sum_{j=1}^s \sum_{k=1}^t T_{ijk} \right) \\
&= \left(L_i - \frac{1}{l} \sum_{i=1}^l L_i \right) + \left(\frac{1}{s} \sum_{j=1}^s S_{ij} - \frac{1}{ls} \sum_{i=1}^l \sum_{j=1}^s S_{ij} \right) \\
&\quad + \left(\frac{1}{st} \sum_{j=1}^s \sum_{k=1}^t T_{ijk} - \frac{1}{lst} \sum_{i=1}^l \sum_{j=1}^s \sum_{k=1}^t T_{ijk} \right)
\end{aligned}$$

so,

$$\begin{aligned}
E[(y_{i...} - y_{...})^2] &= E \left[\left(L_i - \frac{1}{l} \sum_{i=1}^l L_i \right) + \left(\frac{1}{s} \sum_{j=1}^s S_{ij} - \frac{1}{ls} \sum_{i=1}^l \sum_{j=1}^s S_{ij} \right) \right. \\
&\quad \left. + \left(\frac{1}{st} \sum_{j=1}^s \sum_{k=1}^t T_{ijk} - \frac{1}{lst} \sum_{i=1}^l \sum_{j=1}^s \sum_{k=1}^t T_{ijk} \right) \right]^2 \\
&= E[L_i^2] - E \left[\left(\frac{1}{l} \sum_{i=1}^l L_i \right)^2 \right] + E \left[\left(\frac{1}{s} \sum_{j=1}^s S_{ij} \right)^2 \right] - E \left[\left(\frac{1}{ls} \sum_{i=1}^l \sum_{j=1}^s S_{ij} \right)^2 \right] \\
&\quad + E \left[\left(\frac{1}{st} \sum_{j=1}^s \sum_{k=1}^t T_{ijk} \right)^2 \right] - E \left[\left(\frac{1}{lst} \sum_{i=1}^l \sum_{j=1}^s \sum_{k=1}^t T_{ijk} \right)^2 \right]
\end{aligned}$$

$$\begin{aligned}
&= \sigma_M^2 - \frac{l\sigma_M^2}{l^2} + \frac{s\sigma_S^2}{s^2} - \frac{ls\sigma_S^2}{l^2s^2} + \frac{st\sigma_T^2}{s^2t^2} - \frac{lst\sigma_T^2}{l^2s^2t^2} \\
&= \sigma_M^2 - \frac{\sigma_M^2}{l} + \frac{\sigma_S^2}{s} - \frac{\sigma_S^2}{ls} + \frac{\sigma_T^2}{st} - \frac{\sigma_T^2}{lst} \\
&= \left(\frac{l-1}{l}\right)\sigma_M^2 + \left(\frac{l-1}{ls}\right)\sigma_S^2 + \left(\frac{l-1}{lst}\right)\sigma_T^2
\end{aligned}$$

therefore,

$$\begin{aligned}
E[MS_L] &= \frac{1}{(l-1)} \sum_{i=1}^l \sum_{j=1}^s \sum_{k=1}^t \left[\left(\frac{l-1}{l}\right)\sigma_M^2 + \left(\frac{l-1}{ls}\right)\sigma_S^2 + \left(\frac{l-1}{lst}\right)\sigma_T^2 \right] \\
&= \left(\frac{lst}{l-1}\right)\left(\frac{l-1}{l}\right)\sigma_M^2 + \left(\frac{lst}{l-1}\right)\left(\frac{l-1}{ls}\right)\sigma_S^2 + \left(\frac{lst}{l-1}\right)\left(\frac{l-1}{lst}\right)\sigma_T^2 \\
&= st\sigma_M^2 + t\sigma_S^2 + \sigma_T^2
\end{aligned}$$

A summary of the equations derived for the *expected mean squares* is provided below for convenience.

$$E(MS_T) = \sigma_T^2 \quad (8)$$

$$E(MS_S) = t\sigma_S^2 + \sigma_T^2 \quad (9)$$

$$E(MS_L) = st\sigma_M^2 + t\sigma_S^2 + \sigma_T^2 \quad (10)$$

In theoretical statistics, $\hat{\theta}$ is an *unbiased* estimator of θ if $E(\hat{\theta}) = \theta$. Equations 8, 9, and 10 indicate that MS_T , MS_S , and MS_L are unbiased estimators of σ_T^2 , $t\sigma_S^2 + \sigma_T^2$, and $st\sigma_M^2 + t\sigma_S^2 + \sigma_T^2$, respectively. Therefore, estimates of σ_T^2 , σ_S^2 , and σ_M^2 can be derived by equating the *computed mean squares* to their corresponding expectations, that is,

$$MS_T = \sigma_T^2 \quad (11)$$

$$MS_S = t\sigma_S^2 + \sigma_T^2 \quad (12)$$

$$MS_L = st\sigma_M^2 + t\sigma_S^2 + \sigma_T^2 \quad (13)$$

The simultaneous solution of equations 11, 12, and 13 yields the following:

$$\hat{\sigma}_T^2 = MS_T \quad (14)$$

$$\hat{\sigma}_S^2 = \frac{MS_S - MS_T}{t} \quad (15)$$

$$\hat{\sigma}_M^2 = \frac{MS_L - MS_S}{st} \quad (16)$$

Since the above estimates are obtained by subtraction, it is possible that their values can be negative.

Using the additive property of variances shown in Table 2, it can be shown that the total variance of the measurements is the sum of the component variances, that is,

$$\begin{aligned} \sigma_{Total}^2 &= V(y_{ijk}) = V(\mu + L_i + S_{ij} + T_{ijk}) \\ &= V(\mu) + V(L_i) + V(S_{ij}) + V(T_{ijk}) \\ &= 0 + \sigma_M^2 + \sigma_S^2 + \sigma_T^2 \end{aligned}$$

and an estimate of the total variance is:

$$\hat{\sigma}_{Total}^2 = \hat{\sigma}_M^2 + \hat{\sigma}_S^2 + \hat{\sigma}_T^2 \quad (17)$$

A summary of the foregoing analysis of variance is presented in Table 3.

Hypothesis Testing and Use of the F-ratio

Test for subplot-to-sublot variation

To test the hypothesis:

$$H_0: \sigma_M^2 = 0$$

$$H_1: \sigma_M^2 > 0$$

the appropriate test statistics is given by:

$$F_M = \frac{MS_L}{MS_S} = \frac{\sigma_T^2 + t\sigma_S^2 + st\sigma_M^2}{\sigma_T^2 + t\sigma_S^2} \quad (18)$$

When H_0 is true (i.e, when $\sigma_M^2 = 0$), the distribution of the above test statistics is the *F distribution* with $(l - 1)$ degrees of freedom for the numerator and $l(s - 1)$ degrees of freedom for the denominator [19]. The computed F given by equation 18 is compared with a tabulated value for a given level of significance α . The decision rule for the above hypothesis is as follows:

If $F_M > F_{Tabulated}$ Reject H_0

If $F_M \leq F_{Tabulated}$ Accept H_0

Rejecting H_0 indicates that "subplot-to-sublot" variation exists, i.e, the material used to construct the lot is not uniform. On the other hand, accepting H_0 means that there is no variation between sublots, i.e, the material is uniform across the lot.

TABLE 3
ANALYSIS OF VARIANCE TABLE

Source of Variation	Sum of Squares	Degrees of Freedom	Mean Square	Expected Mean Square
Between Sublots	SS_L	$l - 1$	MS_L	$\sigma_T^2 + t\sigma_s^2 + st\sigma_M^2$
Between Sample units	SS_S	$l(s - 1)$	MS_S	$\sigma_T^2 + t\sigma_s^2$
Between Tests	SS_T	$ls(t - 1)$	MS_T	σ_T^2
Total	SS_{Total}	$lst - 1$		

Test for sample unit-to-sample unit variation

To test the hypothesis:

$$H_o: \sigma_s^2 = 0$$

$$H_1: \sigma_s^2 > 0$$

the appropriate test statistics is given by:

$$F_s = \frac{MS_s}{MS_T} = \frac{\sigma_T^2 + t\sigma_s^2}{\sigma_T^2} \quad (19)$$

When H_o is true (i.e, when $\sigma_s^2 = 0$), the distribution of the above test statistics is the *F distribution* with $l(s - 1)$ degrees of freedom for the numerator and $ls(t - 1)$ degrees of freedom for the denominator [19]. For a given level of significance α , the decision rule for the above hypothesis is as follows:

If $F_s > F_{Tabulated} \dots\dots$ Reject H_o

If $F_s \leq F_{Tabulated} \dots\dots$ Accept H_o

Rejecting H_o indicates that "sample unit-to-sample unit" variation exists, i.e, the contribution of sampling to the overall variation is significant. On the other hand, accepting H_o means that there is no variation between sample units, i.e, the contribution of sampling is not significant.

Some Remarks Concerning F-ratios That are Less Than Unity

With reference to equations 18 and 19, the F-ratios (F_M and F_s) are expected to be greater than one, i.e., σ_M^2 and σ_s^2 are positive. However, it is possible that the

calculated F-value (F_M or F_S) will be less than one. This means that σ_M^2 or σ_S^2 is negative !

Ostle [15], suggested two possible solutions to the problem of negative variances (i.e, $\sigma_M^2 < 0$ or $\sigma_S^2 < 0$). The first solution is to assume that σ_M^2 (or σ_S^2) equals zero. The second solution is to calculate the inverse of F_M (or F_S), denoted as F'_M (or F'_S), and test its significance. Note that the degrees of freedom have to be interchanged. If F'_M (or F'_S) turns out to be significant, one should consider rejecting the *postulated statistical model*. Ostle recommended some steps that should be taken when the model is rejected because of a significant F'_M (or F'_S). Some of these are:

- The underlying phenomenon should be restudied to see if the assumed *linear model* is a good approximation to the true state of affairs.
- The assumptions of additivity, normality, homogeneity of variances, and independence should be checked to asses their validity.

A Numerical Example

Table 4 gives the percent of material passing the 3/8 inch sieve of a lot of highway material [7]. The lot is divided into 21 sublots of equal sizes and duplicate sample units are obtained from each subplot at random. Each sample unit is then split into two test portions.

Computational formulas

Computations of the sums of squares can be made less tedious by utilizing the following expression:

TABLE 4
DATA FOR MATERIAL PASSING 3/8 INCH SIEVE

Sublot No.	Sample Unit 1		Sample Unit 2	
	Test 1	Test 2	Test 1	Test 2
1	71.6	69.0	69.4	76.4
2	69.3	72.2	67.7	67.5
3	65.0	72.7	71.1	73.6
4	73.0	76.0	71.3	68.7
5	76.3	72.1	75.0	74.2
6	71.4	71.1	69.2	69.8
7	73.6	75.9	70.0	67.3
8	72.2	69.4	72.2	72.5
9	76.5	73.8	74.7	66.0
10	74.2	73.2	70.1	66.8
11	76.2	68.0	70.9	71.2
12	74.0	66.5	71.7	73.2
13	72.3	76.5	71.7	70.5
14	65.1	72.3	67.9	69.2
15	68.8	67.6	69.0	73.7
16	76.1	74.2	75.4	71.4
17	70.7	74.6	70.7	67.9
18	70.3	70.6	65.3	67.7
19	65.5	68.0	72.1	71.0
20	70.7	66.8	73.8	70.4
21	72.4	71.7	68.5	67.4

$$\sum (X_i - \bar{X})^2 = \sum X_i^2 - \frac{1}{n} [\sum X_i]^2 \quad (20)$$

Application of the above equation to the previously defined sums of squares yields:

$$SS_T = \sum_{i=1}^l \sum_{j=1}^s \sum_{k=1}^t y_{ijk}^2 - \frac{1}{t} \sum_{i=1}^l \sum_{j=1}^s \left(\sum_{k=1}^t y_{ijk} \right)^2 \quad (21)$$

$$SS_S = \frac{1}{t} \sum_{i=1}^l \sum_{j=1}^s \left(\sum_{k=1}^t y_{ijk} \right)^2 - \frac{1}{st} \sum_{i=1}^l \left(\sum_{j=1}^s \sum_{k=1}^t y_{ijk} \right)^2 \quad (22)$$

$$SS_L = \frac{1}{st} \sum_{i=1}^l \left(\sum_{j=1}^s \sum_{k=1}^t y_{ijk} \right)^2 - \frac{1}{lst} \left(\sum_{i=1}^l \sum_{j=1}^s \sum_{k=1}^t y_{ijk} \right)^2 \quad (23)$$

$$SS_{Total} = \sum_{i=1}^l \sum_{j=1}^s \sum_{k=1}^t y_{ijk}^2 - \frac{1}{lst} \left(\sum_{i=1}^l \sum_{j=1}^s \sum_{k=1}^t y_{ijk} \right)^2 \quad (24)$$

The analysis of variance for the data from Table 4 is summarized in Table 5.

Estimates of σ_M^2 , σ_S^2 , and σ_T^2 are obtained by solving equations 14, 15, and 16.

These estimates are:

$$\hat{\sigma}_T^2 = 6.98$$

$$\hat{\sigma}_S^2 = 2.56$$

$$\hat{\sigma}_M^2 = (-0.38)$$

and the total variance estimate is:

$$\hat{\sigma}_{Total}^2 = (-0.38) + 2.56 + 6.98 = 9.17$$

It is seen that the largest component of variance is due to the testing method.

To check if there is variation due to the sampling method, the calculated F-ratio is

$F_S = 12.1 / 6.98 = 1.73$. For a 5% level of significance the tabulated F-ratio is

$F_{(v_1, v_2), \alpha} = F_{(21, 42), 0.05} = 1.81$, where v_1 is the number of degrees of freedom associated

TABLE 5
ANALYSIS OF VARIANCE TABLE
FOR DATA FROM TABLE 4

Source of Variation	Sum of Squares	Degrees of Freedom	Mean Square	Expected Mean Square
Between Sublots	212.01	20	10.6	$\sigma_T^2 + t\sigma_S^2 + st\sigma_M^2$
Between Sample units	254.20	21	12.1	$\sigma_T^2 + t\sigma_S^2$
Between Tests	293.27	42	6.98	σ_T^2
Total	759.48	83		

with the numerator in equation 19 and v_2 is the number of degrees of freedom associated with the denominator. Since $F_{\text{Tabulated}}$ is greater than $F_{\text{Calculated}}$, H_0 is accepted. This means that the contribution of sampling to the total variance is not significant.

Estimate of σ_M^2 resulted in a negative value. Therefore, the calculated F-ratio, F_M , is less than one. The value of F'_M is equal to $1/F_M = 1/0.88 = 1.14$ and the corresponding tabulated $F_{(21,20)}$ for a 5% level of significance is 2.11. Since the tabulated F-ratio is greater than the calculated one, F'_M is considered not significant and the best estimate for σ_M^2 is zero. Therefore one can conclude that the material used to construct the lot is uniform.

CHAPTER III

HOW TO USE "NANOVA"

In the previous chapter, a complete analysis of variance for a balanced three-factor nested design was demonstrated. As shown by the example presented in chapter II, the calculations associated with the analysis of variance are tedious and time consuming. To facilitate the computations of components of variance, a computer program, called NANOVA, was developed. Program NANOVA has other features which will be described in this chapter.

The Code Structure

The computer code for NANOVA was developed for the IBM-PC and compatible microcomputers and was written in Microsoft QBasic version 6.00, copyright (C) Microsoft Corporation, 1987-1991 [9]. NANOVA coding is composed of 30 subprograms totalling approximately 299,000 bytes. Each subprogram was compiled individually using Microsoft QBasic compiler. These subprograms are chained together using the QBasic CHAIN statement. Figure 3 depicts a flow diagram which illustrates how these subprograms are linked together. A list of all the NANOVA files with a brief description of their contents is provided in Table 6.

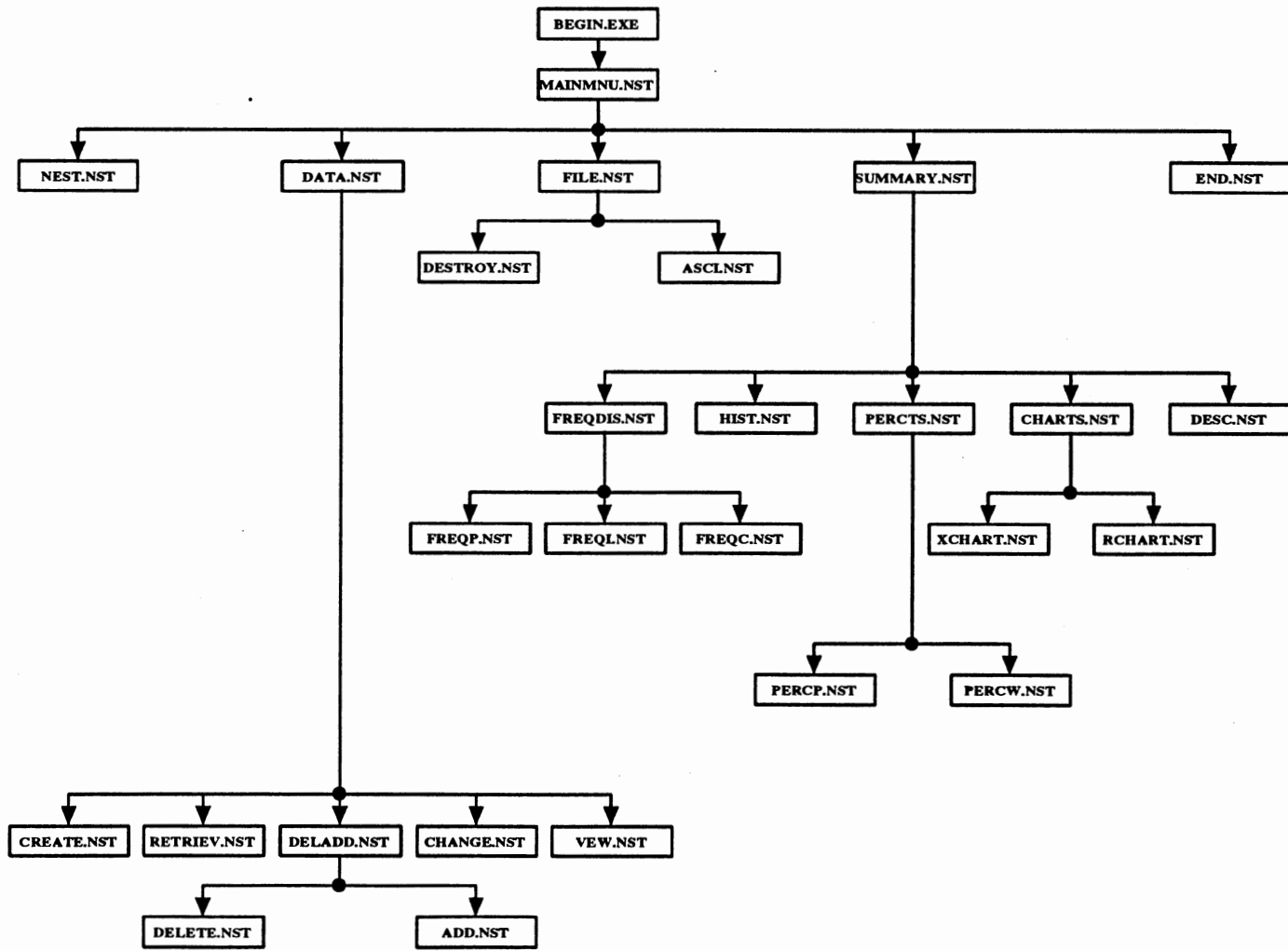

Figure 3. Flow Diagram For NANOVA

TABLE 6
NANOVA FILES

File Name	Contents
BEGIN.EXE	Displays an introductory screen welcoming the user to NANOVA
ADD.NST	Enables the user to add sublots to a given data set
ASCI.NST	Saves the data set in an ascii file format
CHANGE.NST	Enables the user to edit the data set
CHARTS.NST	Displays the CONTROL CHARTS menu
DATA.NST	Displays the DATA MANAGEMENT menu
DELADD.NST	Displays the DELETE/ADD SUBLOTS menu
DELETE.NST	Enables the user to erase sublots from a data set
DESC.NST	Displays a table showing basic statistics (i.e. mean, max, min, etc.) for the data set
DESTROY.NST	Enables the user to erase any file from disk
FILE.NST	Displays the FILE MANAGEMENT menu
FREQC.NST	Displays a cumulative frequency polygon for the data set
FREQDIS.NST	Displays the FREQUENCY DISTRIBUTIONS menu
FREQI.NST	Displays an interval frequency table for the data set
FREQP.NST	Displays a point frequency table for the data set
HIST.NST	Displays a relative frequency histogram for the data set
MAINMNU.NST	Displays the MAIN menu
PERCP.NST	Enables the user to find Pth percentiles
PERCTS.NST	Displays the PERCENTILES menu

TABLE 6 (Continued)

File Name	Contents
PERCW.NST	Enables the user to find the percentage of data within given boundaries
CREATE.NST	Enables the user to create a data set
RCHART.NST	Displays an R control chart for the data set
RETRIEV.NST	Enables the user to use a previously created data set
SUMMARY.NST	Displays the SUMMARY STATISTICS menu
VEW.NST	Displays the data set in a table format
XCHART.NST	Displays an XBAR control chart for the data set
NEST.NST	Displays the nested analysis of variance table
ERR.NST	Halts the execution of the program and displays an error message
END.NST	Displays a message thanking the user for using nest
BRUN60ER.EXE	A QBasic library file

Getting Started

To run NANOVA, insert the diskette containing all the files described in Table 6 in floppy drive A: or B: (or load all files into the fixed disk, e.g., drive C:), then type BEGIN and press <ENTER> at the DOS prompt. The introductory screen shown in Figure 4 will appear. Pressing any key will bring the main menu shown in Figure 5. Each item on the main menu will lead to a new menu with the exception of the "NESTED ANOVA".

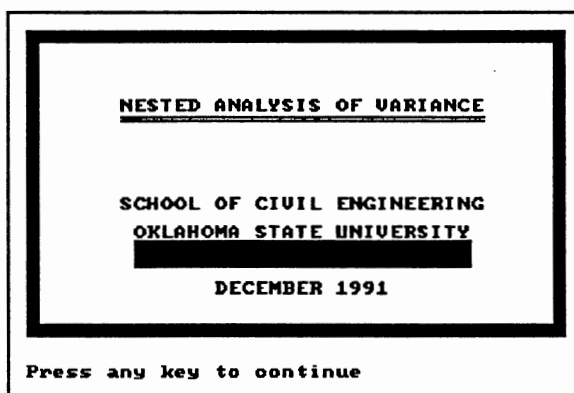

Figure 4. Introductory Screen

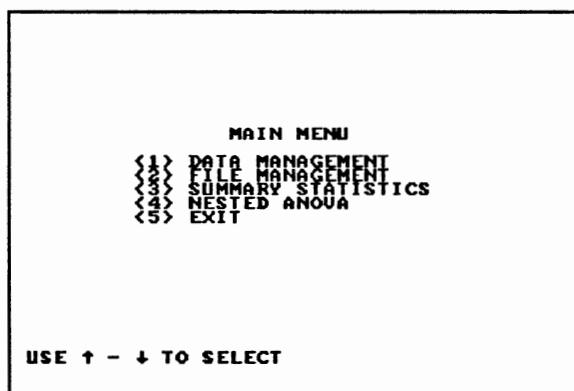

Figure 5. Main Menu

To select one of the items from the main menu, press the item number that is shown next to it. Menu selections can also be made by moving the highlighted bar to the desired choice using the up and down arrow keys, and then pressing <ENTER>. Before attempting to use a statistical procedure, a data set must be created or retrieved using the *Data Management* menu. Unless the data are saved on the fixed drive, the removable diskette containing the data *must* remain in the appropriate drive.

After completing any of the available statistical analyses, a report summarizing the results will be displayed on the screen. If a printed report is needed, press Y when prompted with the following:

DO YOU WANT A PRINTED REPORT (Y/N)

To save a report on disk, press Y when the following question appears:

DO YOU WANT TO SAVE REPORT ON DISK (Y/N)

Each report will be saved in a file that has the same name as the created file but with different file extension. Table 7 shows the available statistical reports and their corresponding file extensions. These extensions are used only if the report is to be saved.

Summary of Procedures

The following is a brief description of the data management, file management, and statistical procedures offered by NANOVA.

TABLE 7
 SAVED FILES AND THEIR CORRESPONDING
 EXTENSIONS

Report Description	Corresponding Extension
Created Data Set	".DAT"
Ascii File	".ASC"
Data Set Listing	".VEW"
Point Frequency	".FRP"
Interval Frequency	".FRI"
Descriptive Statistics	".DES"
Nested ANOVA	".NST"

Data Management

Figure 6 depicts the *Data Management* menu. This menu offers five procedures that are discussed in the following sections.

Create a Data File. The data entry procedure is used to create a new data set by typing in values from the keyboard. After selecting item 1 on the data management menu, the following question will appear on the screen:

ENTER THE FILE NAME (INCLUDE DRIVE AND DIRECTORY):

The data file will be saved under this name. With reference to Table 7, NANOVA will assign the extension ".DAT" to this file.

After entering the filename, press <ENTER>. In addition the user needs to answer the following questions:

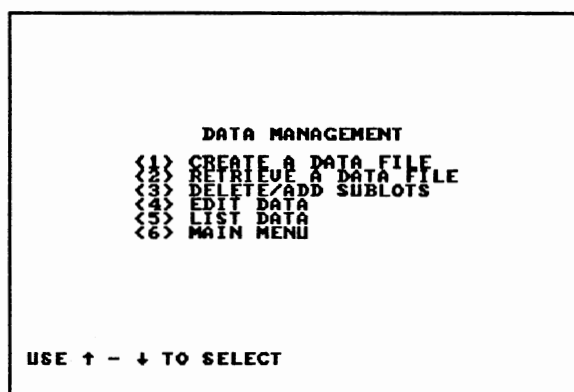

Figure 6. Data Management

ENTER FILE ID. (i.e. PROJECT 2 - SIEVE ANALYSIS):

ENTER # OF SUBLOTS TO BE ANALYZED (INTEGER >1):

ENTER # OF SAMPLE UNITS IN EACH SUBLLOT (INTEGER >1):

ENTER # OF TEST SPECIMENS IN EACH SAMPLE UNIT (INTEGER >1):

The first question is used to identify the data set. The file ID will appear at the top of each output report. The three remaining questions are used to characterize the data set for the nested analysis of variance. After answering these questions, start entering the data set values and press <ENTER> after each entry. Every data set that NANOVA creates can be retrieved by the "LOTUS 1-2-3" computer program.

Retrieve a Data File. This item of the *Data Management* menu will allow the user to retrieve a previously created data set from disk. Type the filename to be retrieved in response to the following question:

ENTER THE FILE NAME (INCLUDE DRIVE AND DIRECTORY):

Delete/Add Sublots. Selecting this item will lead to the menu shown in Figure 7.

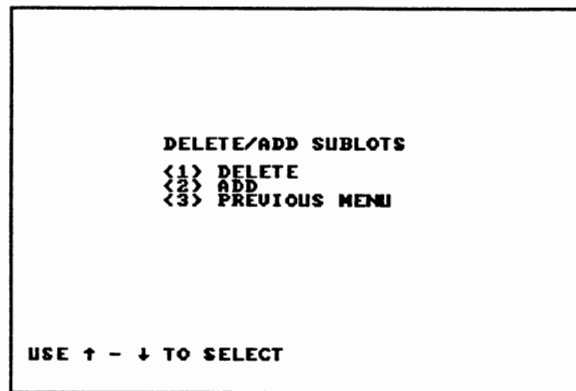

Figure 7. Delete/Add Sublots

This menu allows the user to delete/add sublots from/to the data set. One subplot can be deleted at a time. This is done by entering the number of the subplot to be deleted when asked to do so. On the other hand, the user has the choice to add one or more subplot(s) by following the instructions displayed on the screen.

Edit Data. This procedure is used to edit individual data values in the current data set. It allows the user to correct any mistake which has been made during data entry. When editing a data item, the old value will be shown on the screen.

List Data. This procedure allows the user to view a listing of the data set on the screen. Viewing the data set on the screen can be very helpful in detecting mistakes that have been made in data entry.

File Management

The *File Management* menu shown in Figure 8 offers to the user the ability to delete files from disk and to save the data set in ascii format.

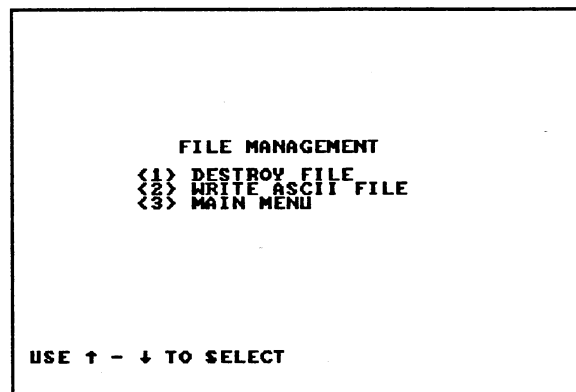

Figure 8. File Management

Destroy File. This procedure is used to erase (delete) files. To destroy a file from disk, type the file name then press <ENTER>. If the file exists on disk, the program will ask for confirmation before deleting it.

Create an Ascii File. Creating an ascii file provides means for reading the data by other programs such as "Statistix". Table 7 shows that the default extension corresponding to this file is ".ASC". If the file is to be retrieved by the "Statistix" program, the user should select the "Single" data format in the READ ASCII FILE procedure.

Summary Statistics

This menu offers a variety of statistical procedures such as histogram, frequency distributions, percentiles, descriptive statistics, and control charts. These procedures are designed to help condense, summarize and display data. They are useful in the preliminary stages of analysis because they allow for recognition of

general patterns and suggest direction for further analysis. The *Summary Statistics* menu is shown in Figure 9.

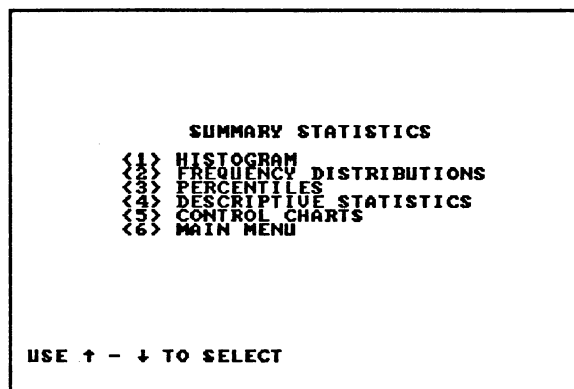

Figure 9. Summary Statistics

Histogram. This procedure produces a relative frequency histogram for the data set. The user can specify the desired interval width.

Frequency Distributions. This item is a menu by itself offering three statistical procedures as shown in Figure 10. The first item on this menu gives a point frequency table for data which are discrete in nature. The next item on this menu provides a similar table for data which are continuous in nature such as asphalt content, percent passing, etc. Item 3 on the *Frequency Distributions* menu offers another way of describing the data set in the form of cumulative frequency curve. Both items 2 and 3 require that an interval width must be provided by the user.

Percentiles. The percentiles menu is shown in Figure 11. This menu offers two statistical procedures, Pth percentile and percentage of data within interval.

Item 1 on this menu computes user specified percentiles for the data set. A percentile must be greater than 0 and less than 100. The second option on this menu gives the percentage of measurements in the data set that fall between user defined boundaries.

```
FREQUENCY DISTRIBUTIONS
<1> POINT FREQUENCY
<2> INTERVAL FREQUENCY
<3> CUM. FREQ. CURVE
<4> PREVIOUS MENU

USE ↑ - ↓ TO SELECT
```

Figure 10. Frequency Distributions

```
PERCENTILES
<1> Pth PERCENTILE
<2> % DATA WITHIN INTERVAL
<3> PREVIOUS MENU

USE ↑ - ↓ TO SELECT
```

Figure 11. Percentiles

Descriptive Statistics. *Descriptive Statistics* computes the maximum, minimum, midrange, median, mean, range, variance, standard of deviation, and coefficient of variation for the data set. All of these statistics are presented in a table format. In

addition, this procedure will calculate the 15th, the 50th and the 85th percentiles for the data set.

Control Charts. The last item on the *Summary Statistics* menu is *Control Charts*, which is also a menu by itself. This menu, which is shown in Figure 12, offers another type of graphical procedures to describe the data set. For example, the X-BAR control chart depicts the measurements that fall outside the band $\mu \pm 2\sigma$ or $\mu \pm 3\sigma$ where μ and σ are the mean and standard deviation of acceptable production. The use of control charts in highway construction work can be very useful in providing a picture of the quality of what is being produced [1].

Before displaying the control charts on the screen, NANOVA will give the user the option of using known population parameters μ and σ as a basis for the calculation of the control charts. The question will appear on the screen as follows:

DO YOU WANT TO USE POPULATION PARAMETERS (Y/N)

If the population parameters, μ and σ , of the attribute that is being tested are known, type Y; otherwise type N. NANOVA will estimate these parameters from the data set if N is chosen as the answer.

Nested ANOVA

The last item on the *Main Menu* is the nested analysis of variance. This procedure gives the results of a balanced three-factor nested analysis of variance for the data set. The computations for this procedure are based on the theory presented in chapter II.

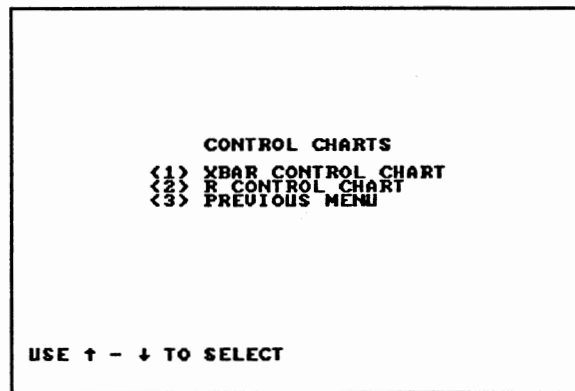

Figure 12. Control Charts

Figures 28 through 31 and Tables 12 through 16 in "APPENDIX A" show the statistical reports produced by NANOVA for the data set presented in Table 4 (chapter II). Table 12 shows a listing of the data set. Tables 13, 14, 15, and 16, respectively, show point frequency, interval frequency, descriptive statistics and nested analysis of variance results for the data set. Figure 28 and 29 present a relative frequency histogram and a cumulative frequency curve, respectively, for the data set. An XBAR and R control chart are depicted in Figures 30 and 31, respectively.

CHAPTER IV

APPLICATION

This chapter presents application of program NANOVA to data obtained from project No. MAF-398(82), highway US-412, Delaware County, OK. Average daily traffic is 5000. A lot of 4000 tons of type-F asphalt concrete mix was selected for sampling and testing. The lot was divided into 25 sublots and two sample units were randomly chosen from each subplot. Each sample unit was then split into two equal test portions which were sent to testing laboratories at the ODOT divisions. The following tests were performed on the specimens:

- Sieve analysis for 1 1/2 ", 1", 3/4", 1/2", 3/8" sieves and sieves No. 4, 10, 40, 80, and 200.
- Percent AC extracted
- Percent AC using nuclear gauge
- Maximum specific gravity (average rices)
- Average lab molded specific gravity (average LMSG)
- Percent air voids
- Core density
- Density measurements using nuclear gauge
- Average stability

NANOVA reports for the nested analysis of variance for each attribute are provided in "APPENDIX B". Tables 8 and 9 summarize these reports. In addition, a summary of the descriptive statistics reports for each attribute is presented in tables 10 and 11.

With reference to Tables 8 and 9 and Figures 13 through 27 the following remarks can be drawn:

Mixture Analysis

Material Variation

Sieves No. 4 and larger - Variability due to materials for sieves No. 4 and larger ranged from 5.67% to 24.55% of the total variation. The percentage of variability due to materials for sieves 3/8", 1/2", 3/4", 1", and sieve No. 4 were 13.99%, 5.67%, 16.82%, 6.22%, and 24.55%, respectively. Sieve No. 4 had the highest percent of variability due to materials among sieves No. 4 and larger.

Sieves No. 10 through 80 - For sieves No. 10 through 80, the variability due to materials ranged from 41.34% to 53.82%. The corresponding percentages for sieves No. 10, 40, and 80 were 41.34%, 53.82%, and 45.30%, respectively. In this group of sieves, sieve No. 40 exhibited the highest percentage of variability due to materials.

Sieve No. 200 - Variability due to materials for sieve No. 200 was 52.01% of the total variance.

Overall, sieve No. 40 had the largest percentage of variability due to materials among all sieves.

TABLE 8

SUMMARY OF NESTED ANOVA REPORTS
(MIXTURE ANALYSIS)

Attribute	Components of Variance						Hypothesis Testing			
	Material		Sampling		Testing		Hypothesis 1 ⁽¹⁾		Hypothesis 2 ⁽²⁾	
	Value	Percent	Value	Percent	Value	Percent	F-ratio	Conclusion ⁽³⁾	F-ratio	Conclusion ⁽³⁾
1 1/2" sieve	0.0000	0.00	0.0000	0.00	0.0000	0.00	0.00	Accept H ₀	0.00	Accept H ₀
1" sieve	0.1871	6.22	0.0000	0.00	2.8198	93.78	1.30	Accept H ₀	0.89	Accept H ₀
3/4" sieve	2.8692	16.82	0.0000	0.00	14.1874	83.18	2.07	Reject H ₀	0.75	Accept H ₀
1/2" sieve	1.1482	5.67	4.5915	22.68	14.5078	71.65	1.19	Accept H ₀	1.63	Accept H ₀
3/8" sieve	3.0184	13.99	4.8226	22.35	13.7324	63.65	1.52	Accept H ₀	1.70	Accept H ₀
No. 4 sieve	2.6955	24.53	3.5309	32.13	4.7640	43.35	1.91	Accept H ₀	2.48	Reject H ₀
No. 10 sieve	1.8909	41.34	0.9660	21.12	1.7168	37.54	3.07	Reject H ₀	2.13	Reject H ₀
No. 40 sieve	0.9686	53.82	0.3058	16.99	0.5253	29.19	4.41	Reject H ₀	2.16	Reject H ₀
No. 80 sieve	0.2667	45.30	0.1763	29.94	0.1458	24.76	3.14	Reject H ₀	3.42	Reject H ₀
No. 200 sieve	0.1862	52.01	0.1118	31.23	0.0600	16.76	3.63	Reject H ₀	4.73	Reject H ₀
% AC (Ext.)	0.0382	40.91	0.0175	18.80	0.0376	40.29	3.10	Reject H ₀	1.93	Reject H ₀
% AC (Nuc.)	0.0852	68.22	0.0210	16.80	0.0187	14.98	6.62	Reject H ₀	3.24	Reject H ₀
Core Density	0.2594	23.36	0.6333	57.03	0.2179	19.62	1.70	Accept H ₀	6.81	Reject H ₀
Nuc. Density	2.1934	43.82	1.7513	34.99	1.0610	21.20	2.92	Accept H ₀	4.30	Reject H ₀
Avg. Rices	0.0000	0.00	0.0006	4.93	0.0109	95.07	0.92	Accept H ₀	1.10	Accept H ₀
Avg. LMSG	0.0006	51.92	0.0005	42.21	0.0001	5.87	3.30	Reject H ₀	15.39	Reject H ₀
% Air Voids	1.5462	53.56	1.0491	36.34	0.2918	10.11	3.59	Reject H ₀	8.19	Reject H ₀
Avg. Stab.	20.5205	68.58	5.0556	16.89	4.3475	14.53	6.68	Reject H ₀	3.33	Reject H ₀

(1) $H_0: \sigma_M^2 = 0, H_1: \sigma_M^2 > 0$

(2) $H_0: \sigma_s^2 = 0, H_1: \sigma_s^2 > 0$

(3) Level of Significance = 5%

TABLE 9
SUMMARY OF NESTED ANOVA REPORTS
(AGGREGATE ANALYSIS)

Attribute	Components of Variance						Hypothesis Testing			
	Material		Sampling		Testing		Hypothesis 1 ⁽¹⁾		Hypothesis 2 ⁽²⁾	
	Value	Percent	Value	Percent	Value	Percent	F-ratio	Conclusion ⁽³⁾	F-ratio	Conclusion ⁽³⁾
1 1/2" sieve	0.0000	0.00	0.0000	0.00	0.0000	0.00	0.00	Accept H ₀	0.00	Accept H ₀
1" sieve	0.3170	22.64	0.0005	0.03	1.0828	77.33	2.17	Reject H ₀	1.00	Accept H ₀
3/4" sieve	1.6014	20.83	0.4317	5.62	5.6545	73.55	1.98	Accept H ₀	1.15	Accept H ₀
1/2" sieve	5.4189	24.22	0.0000	0.00	16.9555	75.78	3.13	Reject H ₀	0.60	Accept H ₀
3/8" sieve	4.6121	18.56	0.0000	0.00	20.2308	81.44	3.02	Reject H ₀	0.45	Accept H ₀ ⁽⁴⁾
No. 4 sieve	1.9480	12.14	0.0000	0.00	14.1044	87.86	2.24	Reject H ₀	0.45	Accept H ₀ ⁽⁴⁾
No. 10 sieve	0.6304	6.29	0.0000	0.00	9.3938	93.71	1.38	Accept H ₀	0.71	Accept H ₀
No. 40 sieve	0.4723	11.88	0.0000	0.00	3.5042	88.12	1.87	Accept H ₀	0.62	Accept H ₀
No. 80 sieve	0.2528	33.40	0.0000	0.00	0.5149	66.60	3.10	Reject H ₀	0.95	Accept H ₀
No. 200 sieve	0.3294	56.66	0.0000	18.44	0.1447	24.90	4.67	Reject H ₀	2.48	Reject H ₀

(1) $H_0: \sigma^2_M = 0, H_1: \sigma^2_M > 0$

(2) $H_0: \sigma^2_s = 0, H_1: \sigma^2_s > 0$

(3) Level of Significance = 5%

(4) F' is significant

TABLE 10

SUMMARY OF DESCRIPTIVE STATISTICS REPORTS
(MIXTURE ANALYSIS)

Attribute	X _{max}	X _{min}	Mean	Range	Variance	Standard Deviation	CV %	Percentiles		
								15th	50th	85th
1 1/2" sieve	100.00	100.00	100.00	0.00	0.00	0.00	0.00	100.0	100.0	100.0
1" sieve	100.00	93.90	98.45	6.10	2.85	1.69	0.02	96.8	98.6	100.0
3/4" sieve	98.70	79.70	89.55	19.00	15.24	3.90	0.04	85.7	89.4	94.4
1/2" sieve	81.30	60.50	71.36	20.80	20.16	4.49	0.06	66.3	71.1	77.0
3/8" sieve	68.90	45.40	59.60	23.50	21.42	4.63	0.08	55.0	59.7	64.9
No. 4 sieve	44.50	27.00	37.70	17.50	10.86	3.30	0.09	34.0	37.9	41.0
No. 10 sieve	29.50	18.50	25.19	11.00	4.50	2.12	0.08	23.1	25.4	27.2
No. 40 sieve	18.40	12.00	15.24	6.40	1.76	1.33	0.09	13.6	15.4	16.5
No. 80 sieve	9.50	5.90	7.67	3.60	0.58	0.76	0.10	6.9	7.8	8.5
No. 200 sieve	5.47	2.23	3.75	3.24	0.35	0.59	0.16	3.2	3.7	4.3
% AC (Ext.)	4.41	3.01	3.75	1.40	0.09	0.30	0.08	3.4	3.8	4.1
% AC (Nuc.)	4.48	3.05	3.75	1.43	0.12	0.35	0.09	3.3	3.8	4.2
Core Density	96.30	91.20	94.10	5.10	1.10	1.05	0.01	93.1	94.1	95.2
Nuc. Density	94.97	82.79	90.34	12.18	4.92	2.22	0.02	88.3	90.1	92.8
Avg. Rices	3.50	2.46	2.51	1.05	0.01	0.11	0.04	2.5	2.5	2.6
Avg. LMSG	2.41	2.18	2.37	0.24	0.00	0.03	0.01	2.3	2.4	2.4
% Air Voids	14.39	2.48	5.29	11.91	2.82	1.68	0.32	4.2	5.0	6.0
Avg. Stab.	63.30	34.00	50.89	29.30	28.93	5.38	0.11	45.6	50.4	56.7

TABLE 11
SUMMARY OF DESCRIPTIVE STATISTICS REPORTS
(AGGREGATE ANALYSIS)

Attribute	X_{max}	X_{min}	Mean	Range	Variance	Standard Deviation	CV %	Percentiles		
								15th	50th	85th
1 1/2" sieve	100.00	100.00	100.00	0.00	0.00	0.00	0.00	100.0	100.0	100.0
1" sieve	100.00	94.80	97.81	5.20	1.39	1.18	0.01	96.6	97.7	99.1
3/4" sieve	92.40	79.60	87.14	12.80	7.63	2.76	0.03	84.2	87.3	89.8
1/2" sieve	76.40	57.30	67.72	19.10	18.85	4.34	0.06	62.4	67.8	73.0
3/8" sieve	65.70	44.70	55.69	21.00	19.20	4.38	0.08	51.1	55.4	60.6
No. 4 sieve	42.60	24.30	33.98	18.30	12.13	3.48	0.10	30.6	33.4	37.9
No. 10 sieve	30.70	14.40	23.43	16.30	8.67	2.94	0.13	20.8	23.1	26.2
No. 40 sieve	19.00	9.40	14.71	9.60	3.31	1.82	0.12	13.0	14.4	16.6
No. 80 sieve	8.60	4.60	6.81	4.00	0.75	0.87	0.13	6.0	6.8	7.9
No. 200 sieve	4.67	0.79	2.99	3.88	0.57	0.75	0.25	2.1	3.1	3.7

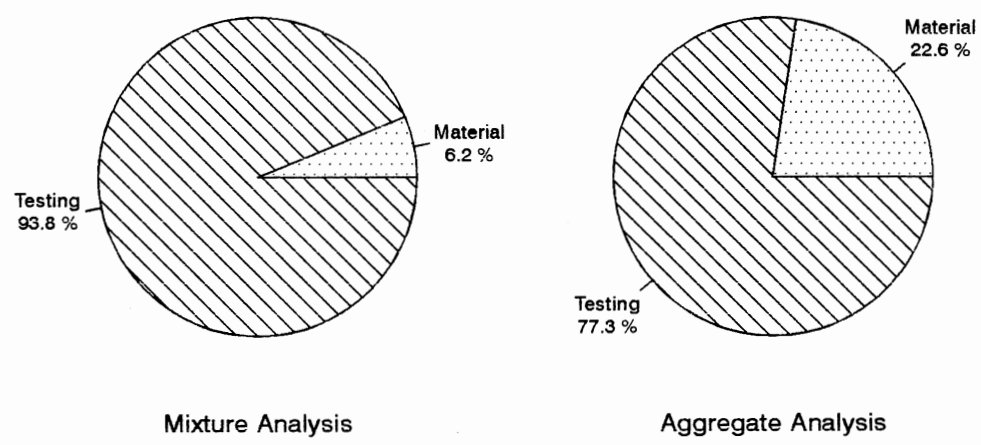
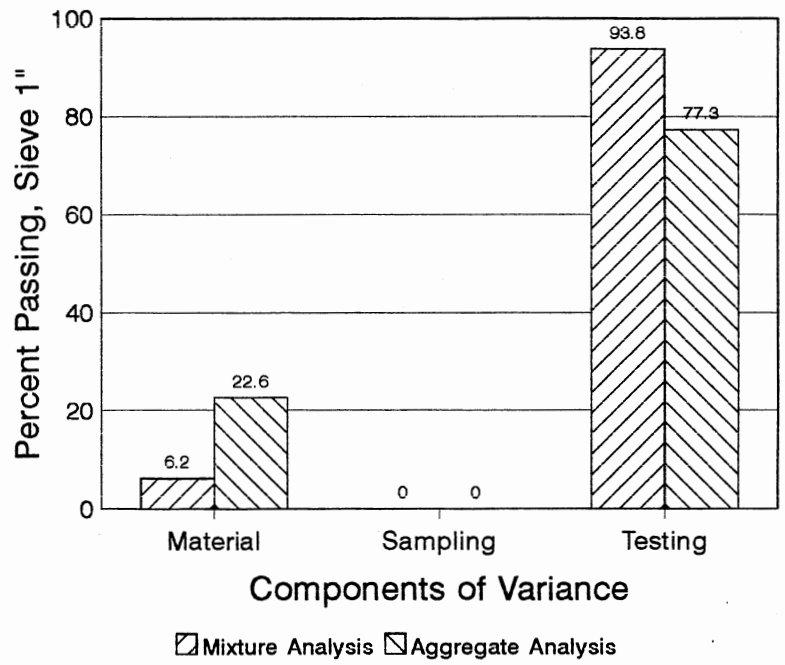

Figure 13. Components of Variance, Mixture Analysis vs. Aggregate Analysis for Sieve 1"

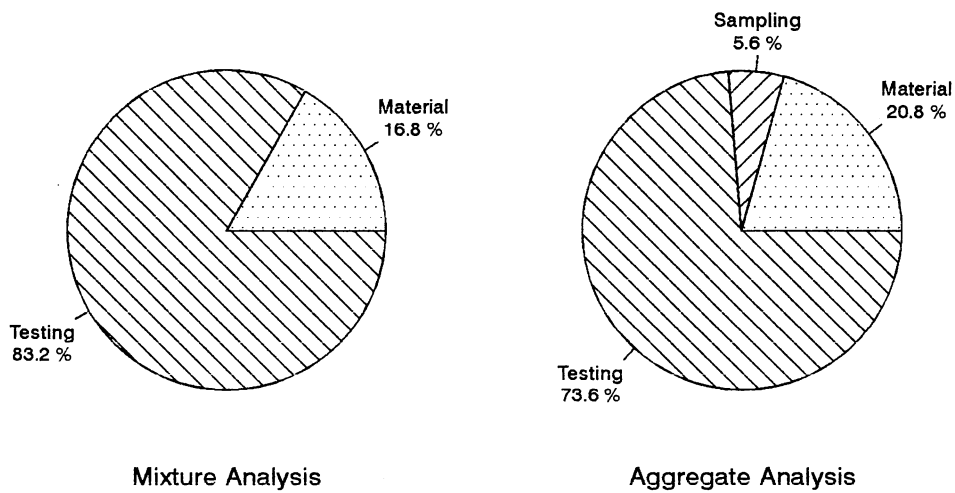
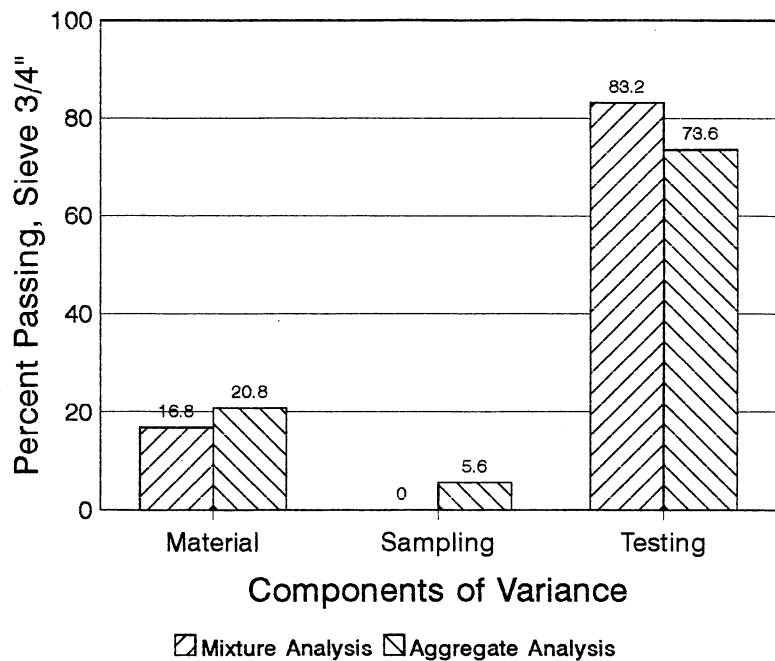

Figure 14. Components of Variance, Mixture Analysis vs. Aggregate Analysis for Sieve 3/4"

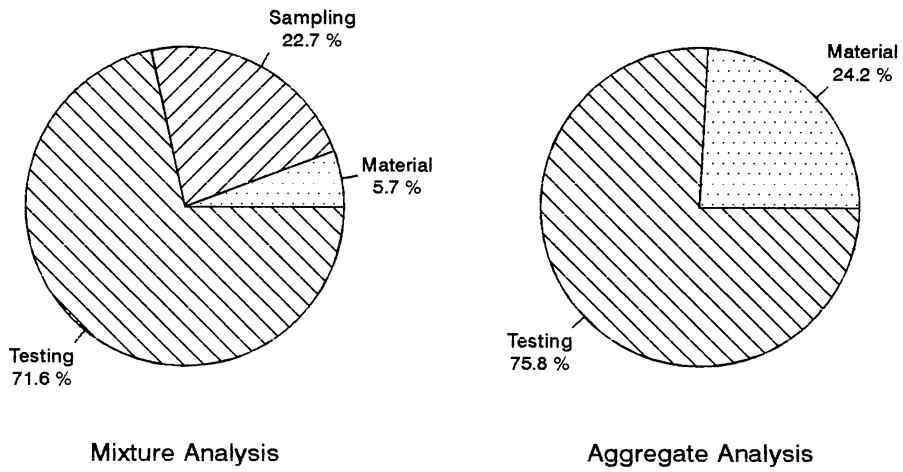
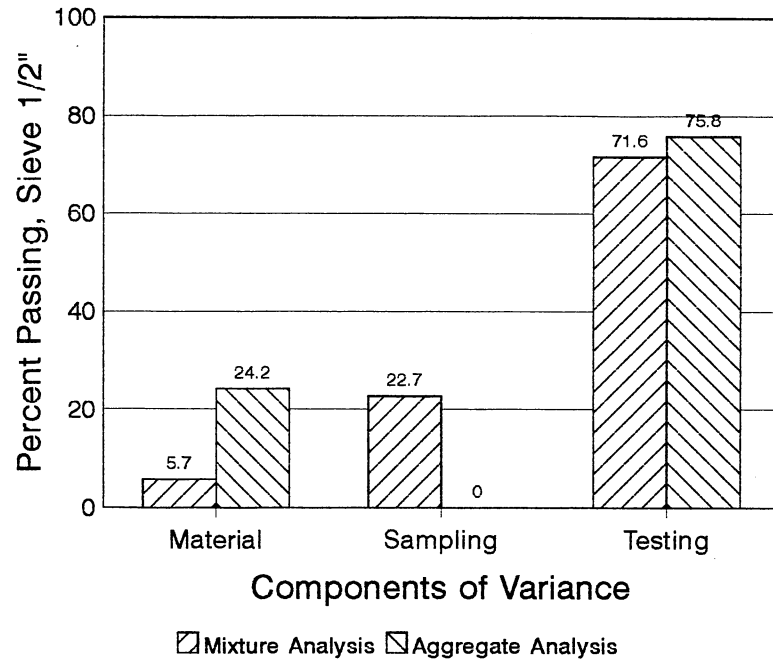

Figure 15. Components of Variance, Mixture Analysis vs. Aggregate Analysis for Sieve 1/2"

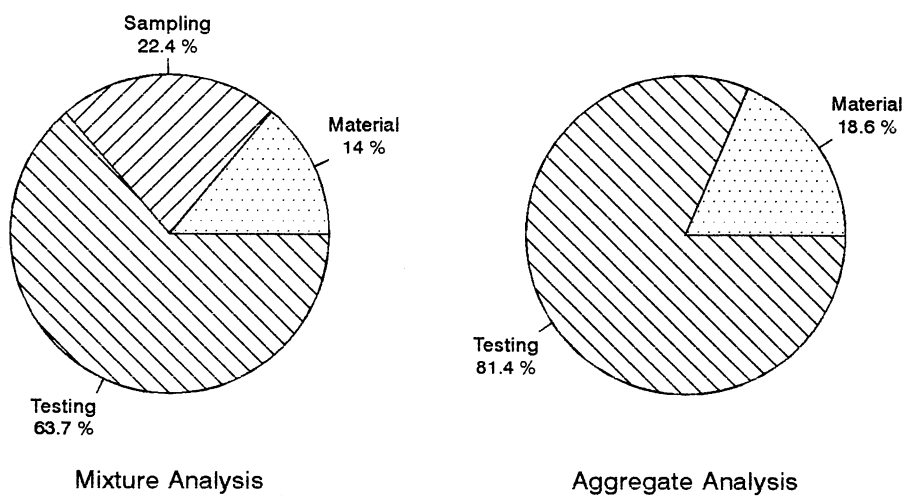
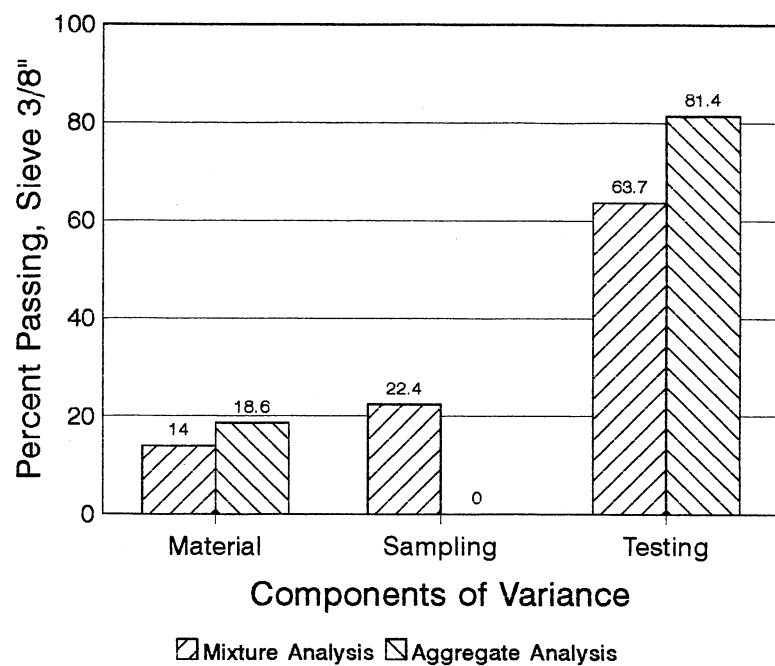

Figure 16. Components of Variance, Mixture Analysis vs. Aggregate Analysis for Sieve 3/8"

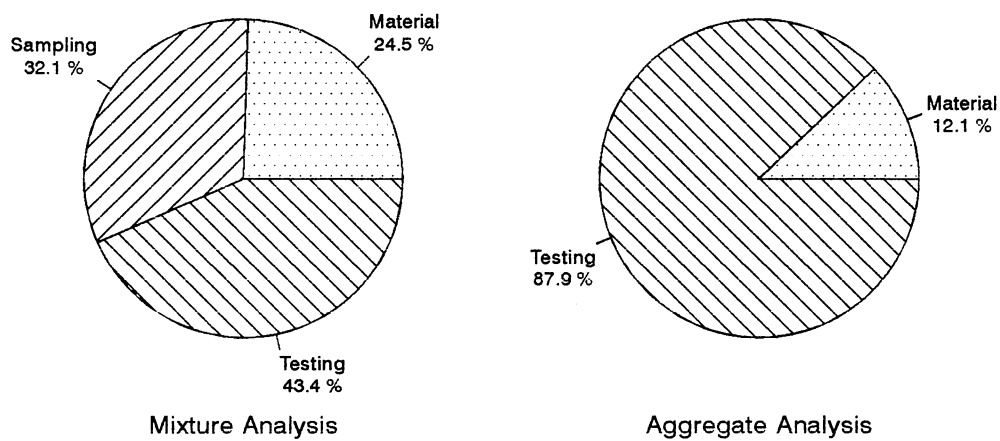
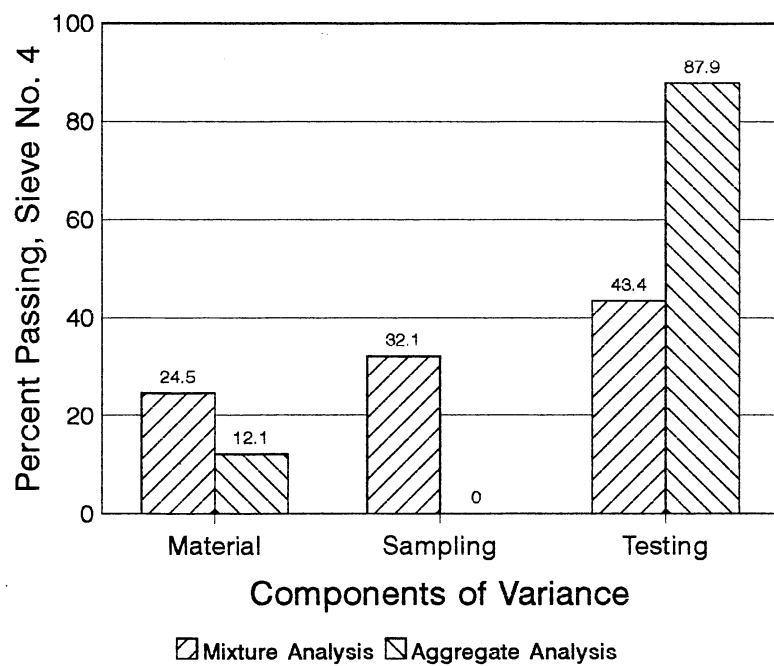

Figure 17. Components of Variance, Mixture Analysis vs. Aggregate Analysis for Sieve No. 4

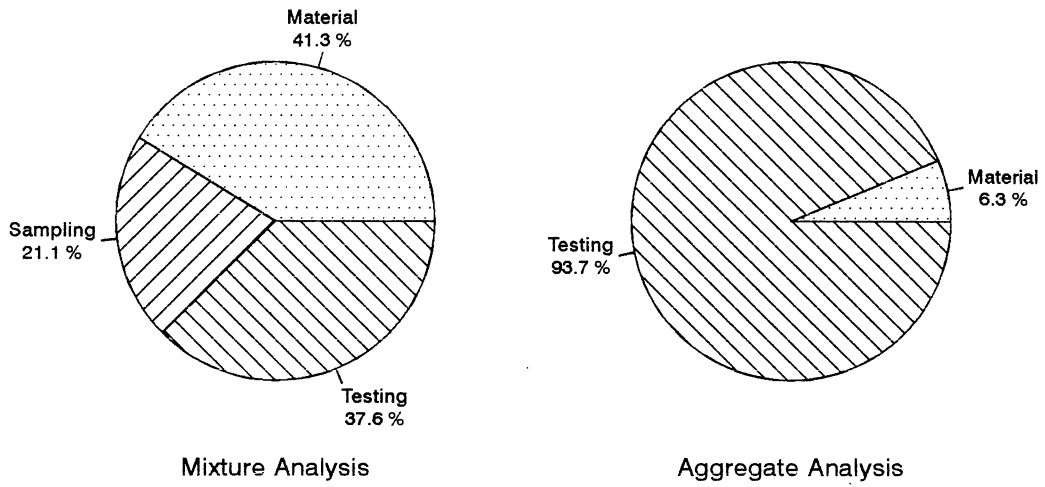
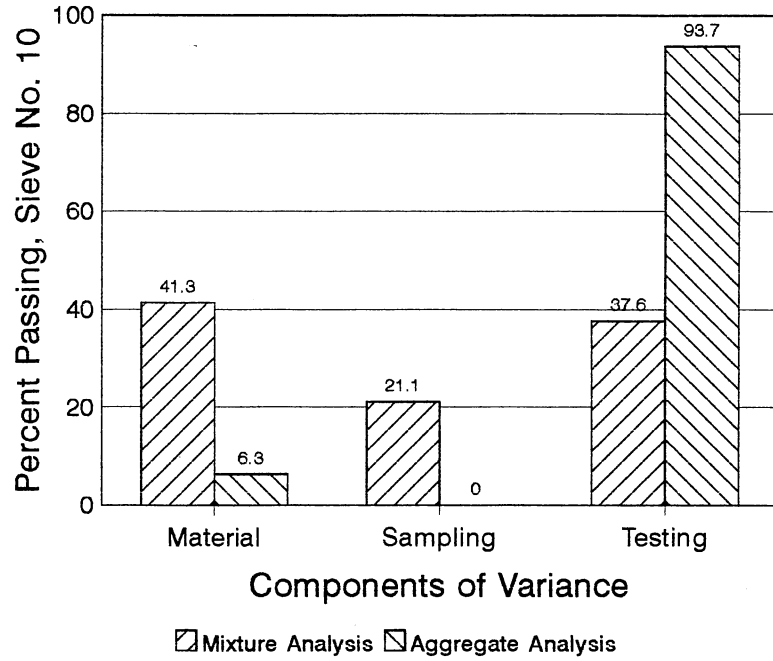
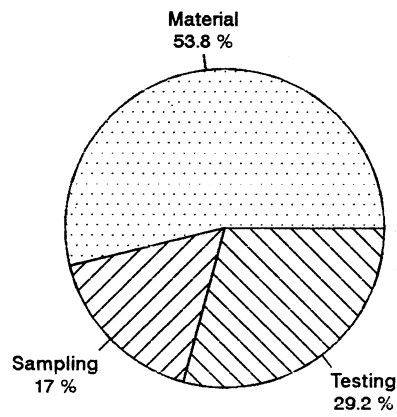
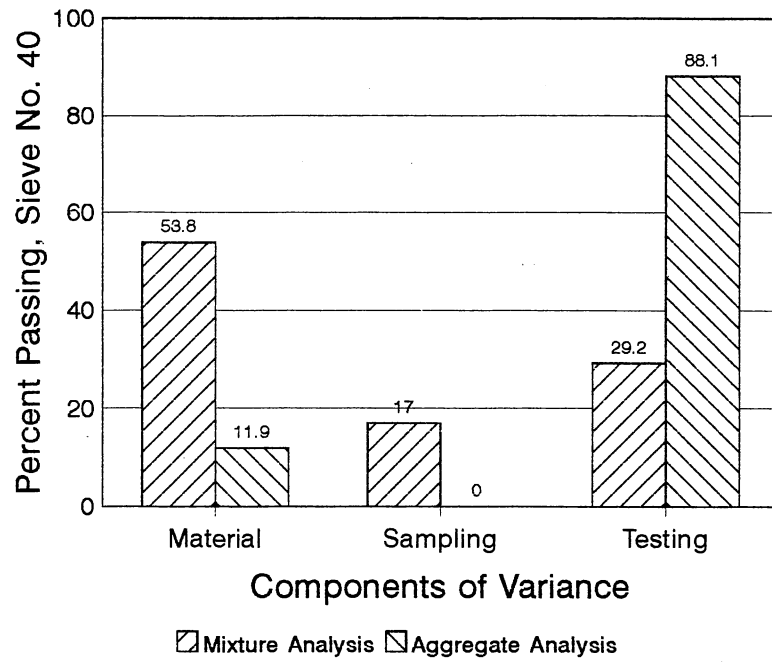
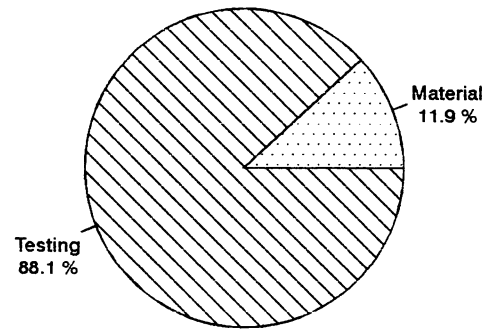

Figure 18. Components of Variance, Mixture Analysis vs. Aggregate Analysis for Sieve No. 10



Mixture Analysis



Aggregate Analysis

Figure 19. Components of Variance, Mixture Analysis vs. Aggregate Analysis for Sieve No. 40

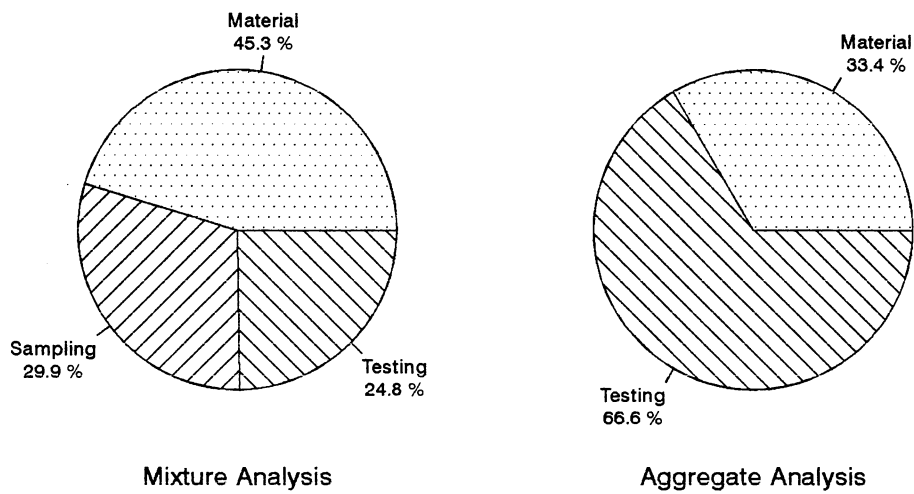
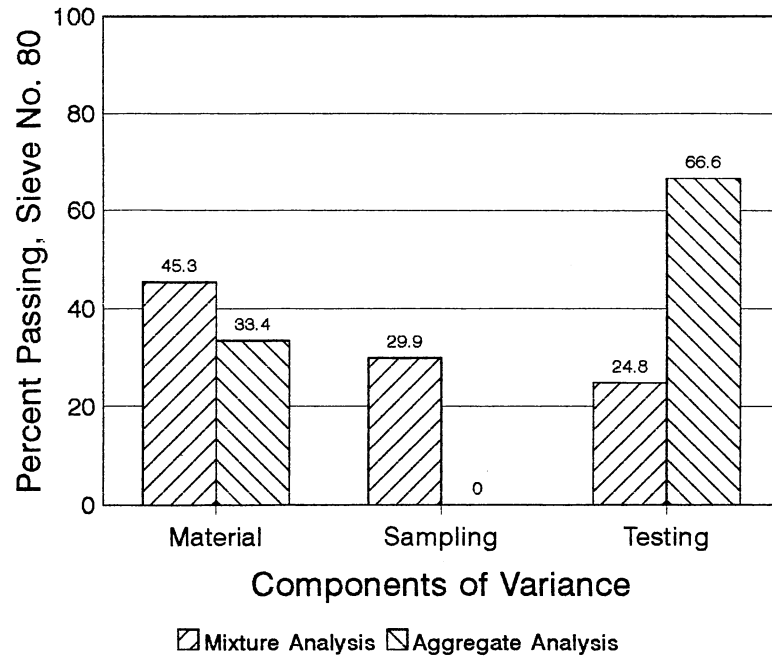

Figure 20. Components of Variance, Mixture Analysis vs. Aggregate Analysis for Sieve No. 80

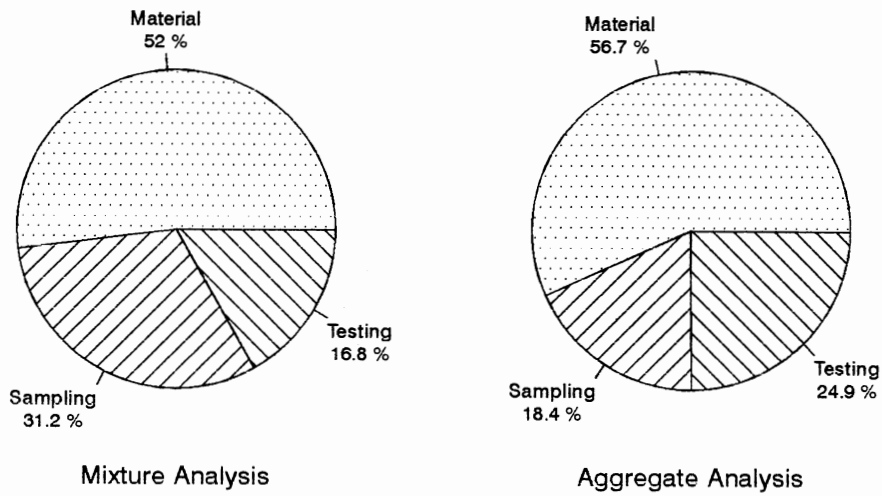
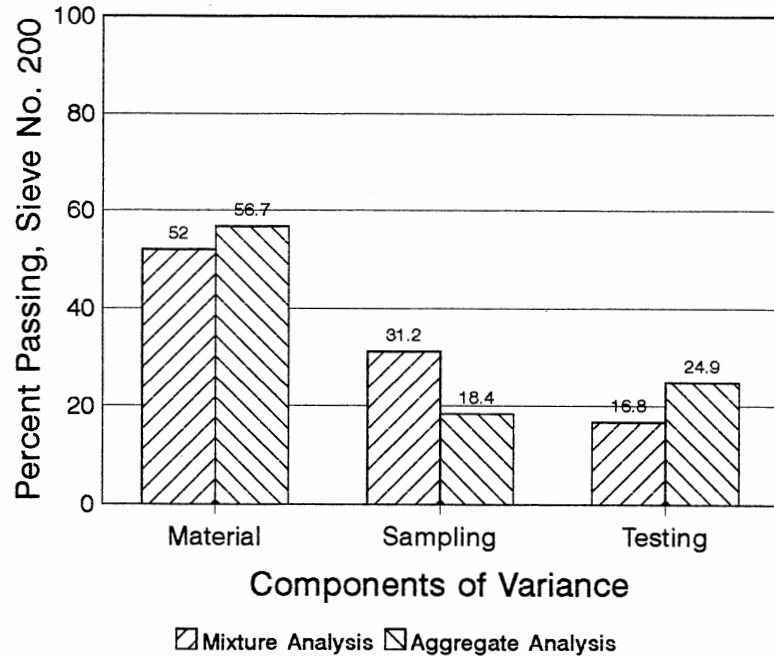

Figure 21. Components of Variance, Mixture Analysis vs. Aggregate Analysis for Sieve No. 200

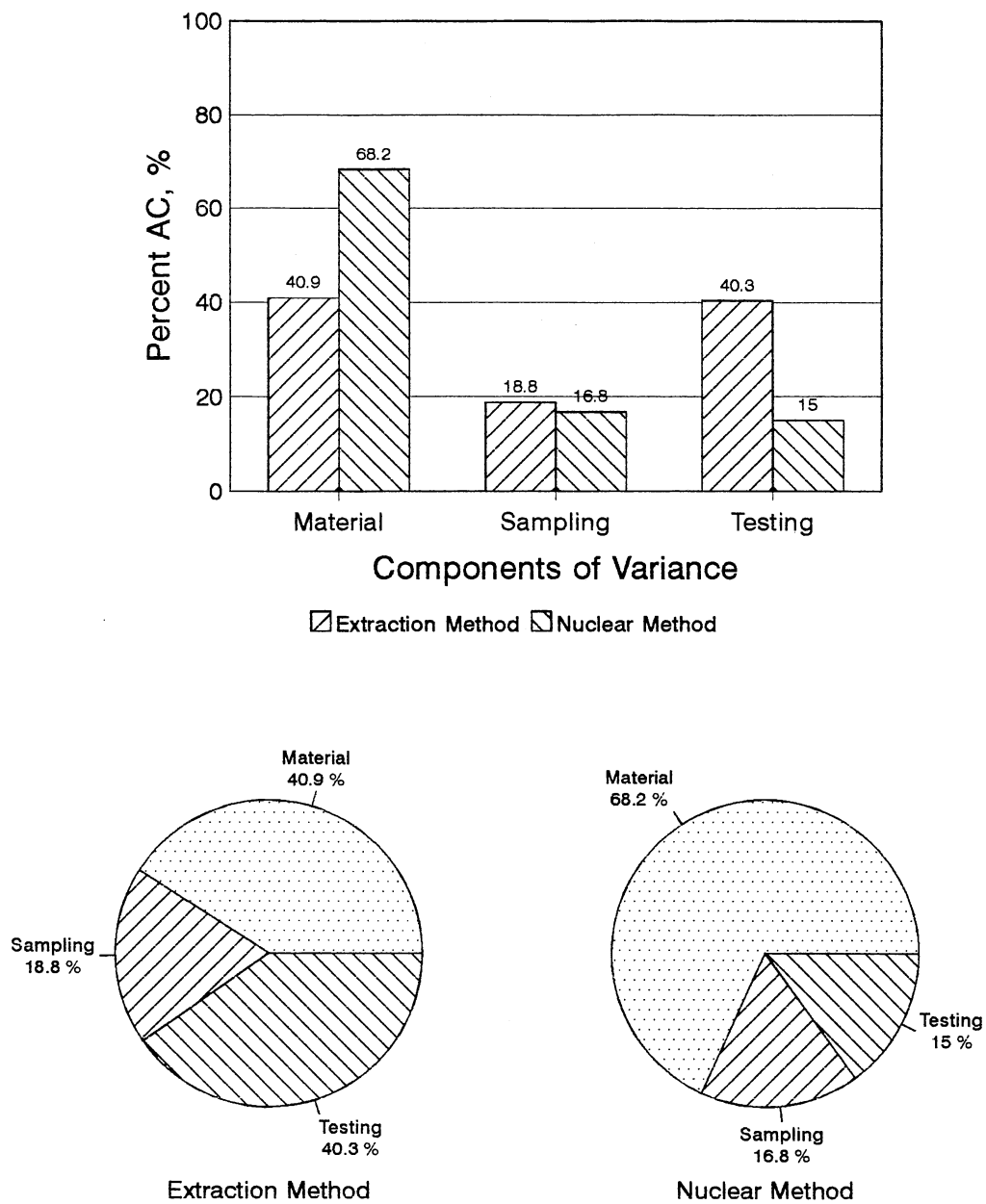

Figure 22. Mixture Analysis, Extracted vs. Nuclear % AC Measurements

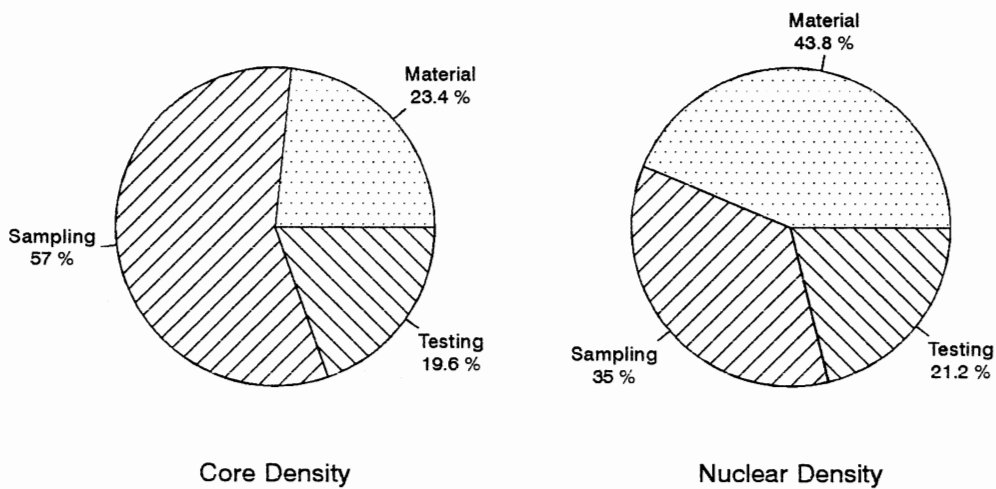
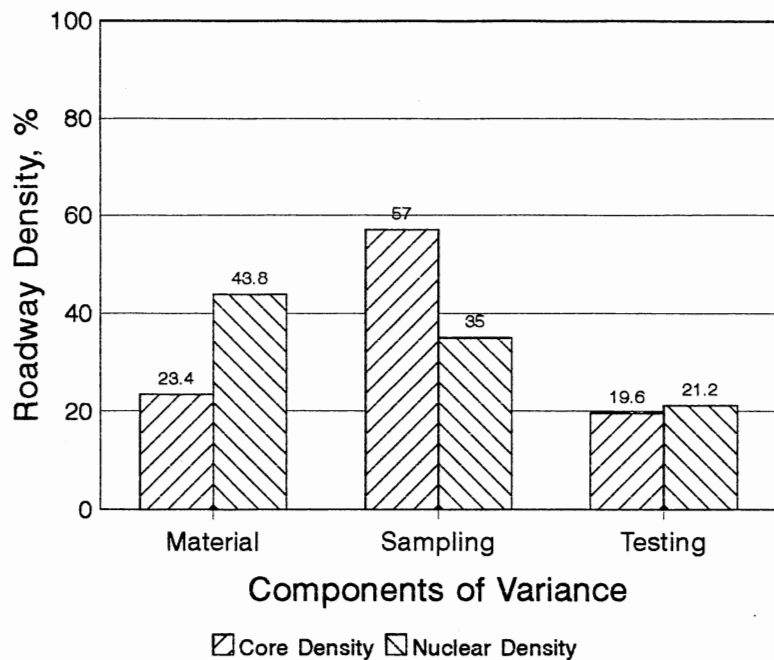

Figure 23. Mixture Analysis, Core Density vs. Nuclear Density

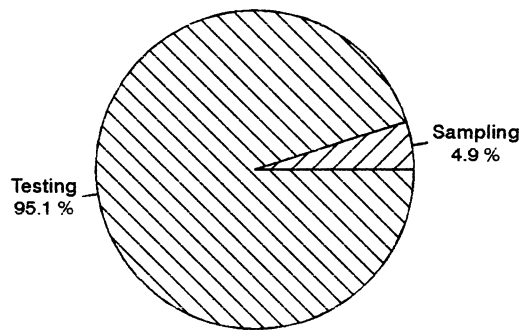
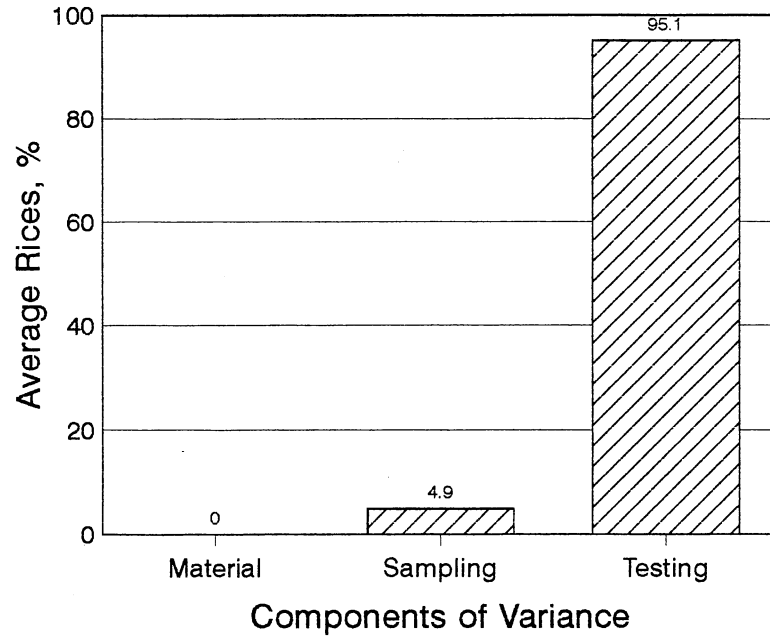

Figure 24. Mixture Analysis, Average Rices

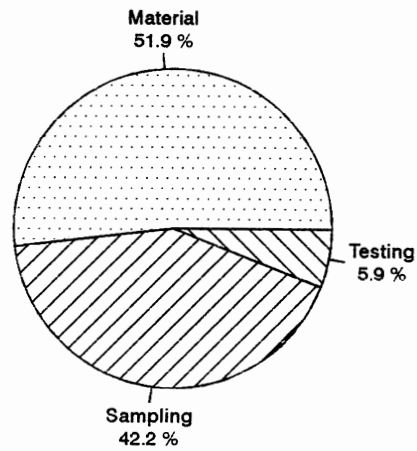
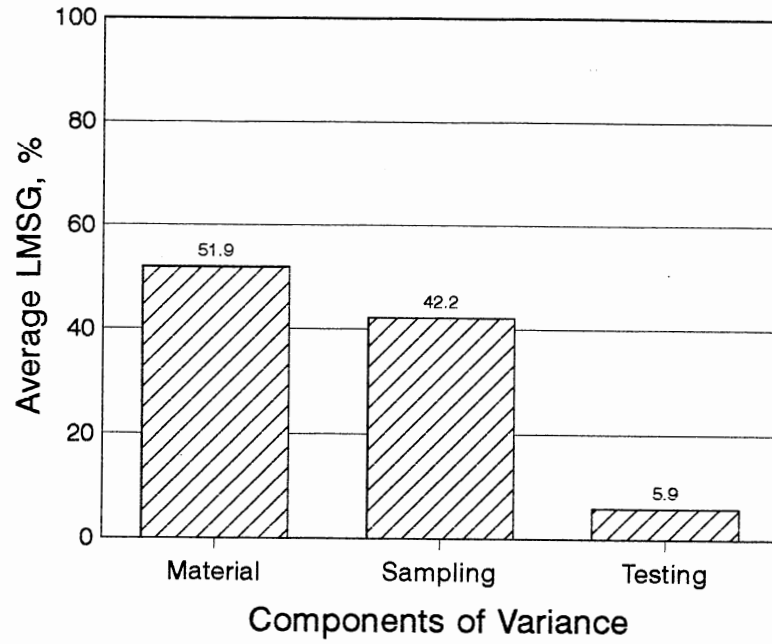

Figure 25. Mixture Analysis, Average LMSG

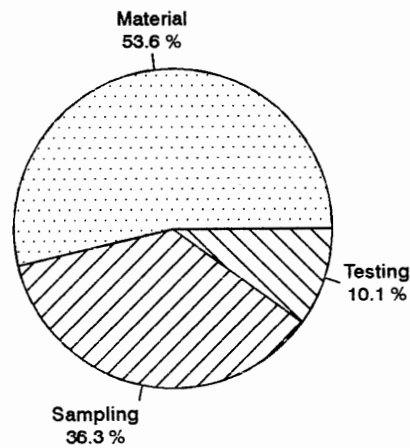
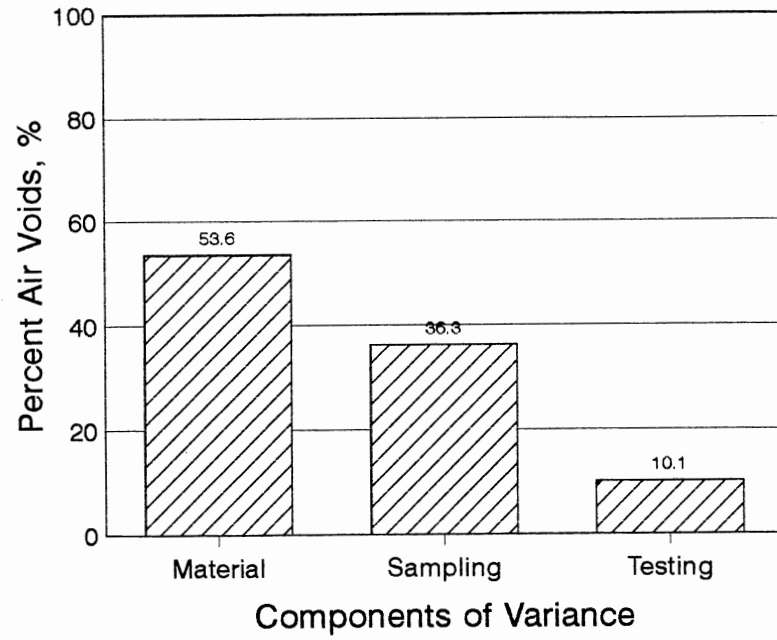

Figure 26. Mixture Analysis, % Air Voids

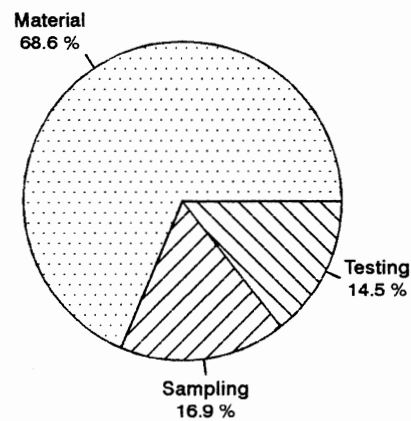
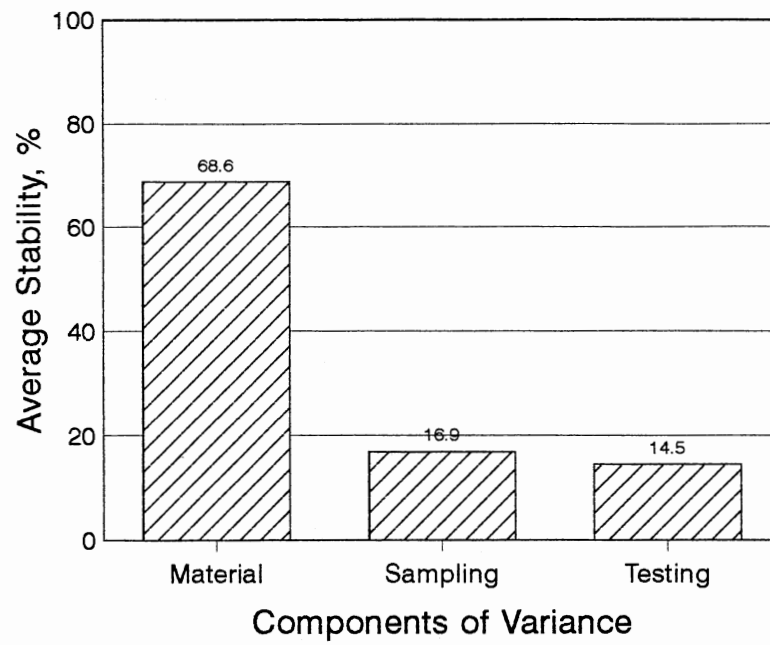

Figure 27. Mixture Analysis, Average Stability

Percent Asphalt Content - Percent AC measurements using the nuclear gauge showed higher percentage of variability due to materials than the extraction method, the percentages were 68.22% and 40.91%, respectively.

Roadway Density - Nuclear density measurements showed higher percentage of variability due to materials than core density measurements, the percentages were 43.82% and 23.36%, respectively.

Average Rices, LMSG, % Air Voids, and Stability - The variability due to materials for average rices, average LMSG, % air voids, and average stability were 0.00%, 51.92%, 53.56%, and 68.58%, respectively.

The highest percentage of variability due to materials in mixture analysis was associated with average stability measurements.

F-Test Results - Results of the F-tests indicated that the percent passing for each of sieves 3/8", 1/2", 1", 1 1/2", and sieve No. 4 is uniform, i.e., material variance is statistically not different from zero at the 95% confidence level. For each of sieves No. 10, 40, 80, 200, and 3/4", the F-tests indicated that percent passing is not uniform, i.e., material variance is statistically different from zero at the 95% confidence level.

Results of the F-tests also indicated that material variance is statistically not different from zero for core density, nuclear density, and average rices measurements. For percent AC measurements using both the nuclear and extracted methods, average LMSG, % air voids, and average stability measurements, the F-tests showed that material variance is statistically significant at the 95% confidence level.

Sampling Variation

Sieves No. 4 and larger - Variability due to sampling for sieves No. 4 and larger ranged from 0.00% to 32.13% of the total variance. The percentages of variability due to sampling for sieves 3/8", 1/2", 3/4", 1", and sieve No. 4 were 22.35%, 22.68%, 0.00%, 0.00%, and 32.13%, respectively. Sieve No. 4 had the highest percent of variability due to sampling among sieves No. 4 and larger.

Sieves No. 10 through 80 - For sieves No. 10 through 80, the variability due to sampling ranged from 16.99% to 29.94%. The percentages of total variation due to sampling for sieves No. 10, 40, and 80 were 21.12%, 16.99%, and 29.94%, respectively. In this group of sieves, sieve No. 80 exhibited the highest percentage of variability due to sampling.

Sieve No. 200 - Variability due to sampling for sieve No. 200 was 31.23% of the total variance.

Overall, sieve No. 4 had the largest percentage of variability due to sampling among all sieves.

Percent Asphalt Content - Percent AC measurements using the extraction method showed higher percentage of total variability due to sampling than % AC measurements using the nuclear gauge, the percentages were 18.80% and 16.80%, respectively.

Roadway Density - Analysis of variance indicated that sampling variance was higher in core density measurements than in nuclear density measurements. The percentages of total variance due to sampling for core density and nuclear density

were 57.03% and 34.99%, respectively.

Average Rices, LMSG, % Air Voids, and Stability - The variability due to sampling for average rices, average LMSG, % air voids, and average stability were 4.93%, 42.21%, 36.34%, and 16.89%, respectively.

The highest percentage of variability due to sampling in mixture analysis was associated with core density measurements.

F-Test Results - Results of the F-tests indicated that for each of sieves 3/8", 1/2", 3/4", 1", and 1 1/2" the contribution of sampling to the total variance is statistically not significant at the 95% confidence level. For sieve No. 4, 10, 40, 80, and 200, the F-tests indicated that sampling variance is statistically different from zero at the 95% confidence level.

Results of the F-tests also indicated that for average rices measurements, the contribution of sampling to the total variance is statistically not significant at the 95% confidence level. For percent AC measurements using both the nuclear and extracted methods, core density, nuclear density, average LMSG, % air voids, and average stability measurements, the F-tests showed that the contribution of sampling to the total variance is statistically different from zero at the 95% confidence level.

Testing Variation

Sieves No. 4 and larger - Variability due to testing for sieves No. 4 and larger ranged from 43.35% to 93.78% of the total variance. The percentages of variability due to testing for sieves 3/8", 1/2", 3/4", 1", and sieve No. 4 were 63.65%, 71.65%, 83.18%, 93.78%, and 43.35%, respectively. Sieve 1" had the highest percent of

variability due to testing among sieves No. 4 and larger.

Sieves No. 10 through 80 - For sieves No. 10 through 80, the variability due to testing ranged from 24.76% to 37.54%. The percentages of total variation due to testing for sieves No. 10, 40, and 80 were 37.54%, 29.19%, and 24.76%, respectively. In this group of sieves, sieve No. 10 had the highest percentage of variability due to testing.

Sieve No. 200 - Variability due to testing for sieve No. 200 was 16.76% of the total variance.

Overall, Sieve 1" had the largest percentage of variability due to testing among all sieves.

Percent Asphalt Content - Percent AC measurements using the extraction method showed higher percentage of variability due to testing than % AC measurements using the nuclear gauge, the percentages were 40.29% and 14.98%, respectively.

Roadway Density - Nuclear density measurements showed higher percentage of variability due to testing than core density measurements, the percentages were 21.20% and 19.62%, respectively.

Average Rices, LMSG, % Air Voids, and Stability - The percent variability due to testing for average rices, average LMSG, % air voids, and average stability were 95.07%, 5.87%, 10.11%, and 14.53%, respectively.

The highest percentage of variability due to testing in mixture analysis was associated with average rices measurements.

Aggregate Analysis

Material Variation

Sieves No. 4 and larger - Variability due to materials for sieves No. 4 and larger ranged from 12.14% to 24.22% of the total variation. The percentages of variability due to materials for sieves 3/8", 1/2", 3/4", 1", and sieve No. 4 were 18.56%, 24.22%, 20.83%, 22.64%, and 12.14%, respectively. Sieve 1/2" had the highest percentage of variability due to materials among sieves No. 4 and larger.

Sieves No. 10 through 80 - For sieves No. 10 through 80, the variability due to materials ranged from 6.29% to 33.40%. The corresponding percentages for sieves No. 10, 40, and 80 were 6.29%, 11.88%, and 33.40%, respectively. In this group of sieves, sieve No. 80 exhibited the highest percentage of variability due to materials.

Sieve No. 200 - Variability due to materials for sieve No. 200 was 56.66% of the total variance.

Overall, sieve No. 200 had the largest percentage of variability due to materials among all sieves.

F-Test Results - Results of the F-tests indicated that the percent passing for each of sieves 1 1/2" , 3/4", No. 10, and No. 40 is uniform, i.e., material variance is statistically not different from zero at the 95% confidence level. For each of sieves 1", 1/2", 3/8", No. 4, No. 80, and No. 200, the F-tests indicated that percent passing is not uniform, i.e., material variance is statistically different from zero at the 95% confidence level.

Sampling Variation

Sieves No. 4 and larger - Variability due to sampling for sieves No. 4 and larger ranged from 0.00% to 5.62% of the total variance. The percentages of variability due to sampling for sieves 3/8", 1/2", 3/4", 1", and sieve No. 4 were 0.00%, 0.00%, 5.62%, 0.03%, and 0.00%, respectively. Sieve No. 3/4" had the highest percentage of variability due to sampling among sieves No. 4 and larger.

Sieves No. 10 through 80 - For sieves No. 10, 40, and 80, the variability due to sampling was 0.00%.

Sieve No. 200 - Variability due to sampling for sieve No. 200 was 18.44% of the total variance.

Overall, sieve No. 200 had the largest percentage of variability due to sampling among all sieves.

F-Test Results - Results of the F-tests indicated that for each of sieves 1 1/2", 1", 3/4", 1/2", 3/8", No. 4, No. 10, No. 40, and No. 80, the contribution of sampling to the total variance is statistically not significant at the 95% confidence level. For sieve No. 200, the F-tests indicated that sampling variance is statistically different from zero at the 95% confidence level.

Testing Variation

Sieves No. 4 and larger - Variability due to testing for sieves No. 4 and larger ranged from 73.55% to 87.86% of the total variance. The percentages of variability due to testing for sieves 3/8", 1/2", 3/4", 1", and sieve No. 4 were 81.44%, 75.78%,

73.55%, 77.33%, and 87.86%, respectively. Sieve No. 4 had the highest percentage of variability due to testing among sieves No. 4 and larger.

Sieves No. 10 through 80 - For sieves No. 10 through 80, the variability due to testing ranged from 66.60% to 93.71%. The percentages of variability due to testing for sieves No. 10, 40, and 80 were 93.71%, 88.12%, and 66.60%, respectively. In this group of sieves, sieve No. 10 exhibited the highest percentage of variability due to testing.

Sieve No. 200 - Variability due to testing for sieve No. 200 was 24.90% of the total variance.

Overall, sieve No. 10 had the largest percentage due to testing variability among all sieves.

Summary

Aggregate Analysis

- The largest source of variation for sieves No. 4 and larger as well as sieves No. 10 through 80 was due to testing. For sieve No. 200, the largest source of variation was due to materials.
- The second largest source of variation for sieves No. 4 and larger as well as sieves No. 10 through 80 was due to materials. For sieve No. 200, the second largest source of variation was due to testing.
- The smallest source of variation for all sieves included in aggregate analysis was due to sampling.

Mixture Analysis

- The largest source of variation for sieves No. 4 and larger was due to testing. For sieves No. 10 through 80 as well as sieve No. 200, the largest source of variation was due to materials.
- The second largest component of variation for all sieves was due to sampling, except for sieves 3/4", 1", and No. 80. For sieves 3/4" and 1", the second largest component was due to materials, where as for sieve No. 80 testing was the second largest component of variation.
- The smallest component of variation for sieves No. 4 and larger was due to materials except for sieves 3/4" and 1", where sampling was the smallest source of variation. For sieves 10 through 80, the smallest source of variation was due to sampling except for sieve No. 80, where testing was the smallest source of variation. For sieve No. 200, the smallest source of variation was due to testing.

Aggregate Analysis Versus Mixture Analysis

- Overall, percent variability due to sampling was lower in aggregate analysis than in mixture analysis except for sieve No. 80.
- Percent variability due to testing is higher in aggregate analysis than in mixture analysis for sieves 1", 3/4", 1/2", 3/8", No. 4, No. 10, and No. 40.
- Aggregate analysis demonstrated higher percent of variation due to materials for sieves 1", No. 10, 40, 80, and 200 than mixture analysis.

CHAPTER V

CONCLUSIONS

The primary sources of variation in a finished construction product are due to materials, sampling techniques, and testing methods. The complete three-factor nested design presented in chapter II is suitable to determine the contribution of these sources to total variability.

The developed computer program, NANOVA, performs the necessary analysis of variance computations associated with the complete three-factor nested design. Results of applying program NANOVA to data obtained from project No. MAF-398(82), highway US-412, Delaware County, OK, can be summarized as follows:

Aggregate Analysis

- The largest source of variation for sieves No. 4 and larger as well as sieves No. 10 through 80 was due to testing. For sieve No. 200, the largest source of variation was due to materials.
- The second largest source of variation for sieves No. 4 and larger as well as sieves No. 10 through 80 was due to materials. For sieve No. 200, the second largest source of variation was due to testing.
- The smallest source of variation for all sieves included in aggregate analysis

was due to sampling.

Mixture Analysis

- The largest source of variation for sieves No. 4 and larger was due to testing. For sieves No. 10 through 80 as well as sieve No. 200, the largest source of variation was due to materials.
- The second largest component of variation for all sieves was due to sampling, except for sieves 3/4", 1", and No. 80. For sieves 3/4" and 1", the second largest component was due to materials, where as for sieve No. 80 testing was the second largest component of variation.
- The smallest component of variation for sieves No. 4 and larger was due to materials except for sieves 3/4" and 1", where sampling was the smallest source of variation. For sieves 10 through 80, the smallest source of variation was due to sampling except for sieve No. 80, where testing was the smallest source of variation. For sieve No. 200, the smallest source of variation was due to testing.

Aggregate Analysis Versus Mixture Analysis

- Overall, percent variability due to sampling was lower in aggregate analysis than in mixture analysis except for sieve No. 80.
- Percent variability due to testing is higher in aggregate analysis than in mixture analysis for sieves 1", 3/4", 1/2", 3/8", No. 4, No. 10, and No. 40.
- Aggregate analysis demonstrated higher percent of variation due to

materials for sieves 1", No. 10, 40, 80, and 200 than mixture analysis.

REFERENCES

1. Ahmed, S.A., Statistical Methods of QA-QC for Highway Construction, Quality control Quality Assurance Training Program, Oklahoma State University, 1991.
2. American Society for Testing and Materials. Standard practice for Use of the Terms Precision and Bias in ASTM Test Methods, E 177 - 86. Annual Book of ASTM Standards, Vol. 14.02, Philadelphia, PA, 1986.
3. American Society for Testing and Materials. Standard Practice for Preparing Precision and Bias Statements for Test Methods for Construction Materials, C 670 - 87. Annual Book of ASTM Standards, Vol. 4.02, Philadelphia, PA, 1987.
4. Brownlee, K.A., Statistical Theory and Methodology in Science and Engineering. John Wiley and Sons Inc., New York, 1960.
5. Davies, O.L., Statistical Methods in Research and Production with Special Reference to the Chemical Industry. Hafner Publishing Company, New York, 1957.
6. Federal Highway Administration. Demonstration Project No. 42: Highway Quality Assurance - Process Control and Acceptance Plans. FHWA Demonstration Projects Division, Region 15, 1980.
7. Federal Highway Administration. The Statistical Approach to Quality Control in Highway Construction. U.S. Department of Transportation, 1965.
8. Graybill, F.A., An Introduction to Linear Statistical Models. McGraw Hill Book Company Inc., New York, 1961.
9. Herget, D. Microsoft QuickBasic, third edition. Microsoft Corporation, 1988.
10. Johnson, N.L., Statistics and Experimental Design in Engineering and the Physical Sciences. John Wiley and Sons Inc., New York, 1964.
11. Kempthorne O., An Introduction to Genetic Statistics. John Wiley and Sons Inc., New York, 1957.

12. Kempthorne, O., The Design and Analysis of Experiments. John Wiley and Sons Inc., New York, 1952.
13. Keppel, G., Design and Analysis, a Researcher's Handbook. Prentice-Hall, Englewood Cliffs, New Jersey, 1982.
14. McMahon, T.F., et al., Quality Assurance in Highway Construction. Public Roads, Vol. 35. No. 1, Federal Highway Administration, Washington, D.C.
15. Ostle, B., Statistics in Research, Basic Concepts and Techniques for Research Workers. The Iowa State University Press, 1954.
16. Sheffé, H., The Analysis of Variance. John Wiley and Sons Inc., New York, 1959.
17. Steel, R.G.D., Principles and Procedures of Statistics - A Biometrical Approach. McGraw Hill Company, 1960.
18. Willenbrock, J.C., A Manual for Statistical Quality Control of Highway Construction, Volumes 1 & 2. Federal Highway Administration, D.C., 1976.
19. Winer, B.J., Statistical Principles in Experimental Design. McGraw Hill Book Company, 1972.

APPENDIX A
TYPICAL STATISTICAL REPORTS PRODUCED
BY NANOVA

TABLE 12
DATA LIST

PERCENT MATERIAL PASSING 3/8 INCH SIEVE

FILE DESCRIPTION: 21 SUBLOTS
2 SAMPLE UNITS/SUBLOT
2 TEST SPECIMENS/SAMPLE UNIT

Sublot No.	Sample Unit 1		Sample Unit 2	
	Test 1	Test 2	Test 1	Test 2
1	71.6	69.0	69.4	76.4
2	69.3	72.2	67.7	67.5
3	65.0	72.7	71.1	73.6
4	73.0	76.0	71.3	68.7
5	76.3	72.1	75.0	74.2
6	71.4	71.1	69.2	69.8
7	73.6	75.9	70.0	67.3
8	72.2	69.4	72.2	72.5
9	76.5	73.8	74.7	66.0
10	74.2	73.2	70.1	66.8
11	76.2	68.0	70.9	71.2
12	74.0	66.5	71.7	73.2
13	72.3	76.5	71.7	70.5
14	65.1	72.3	67.9	69.2
15	68.8	67.6	69.0	73.7
16	76.1	74.2	75.4	71.4
17	70.7	74.6	70.7	67.9
18	70.3	70.6	65.3	67.7
19	65.5	68.0	72.1	71.0
20	70.7	66.8	73.8	70.4
21	72.4	71.7	68.5	67.4

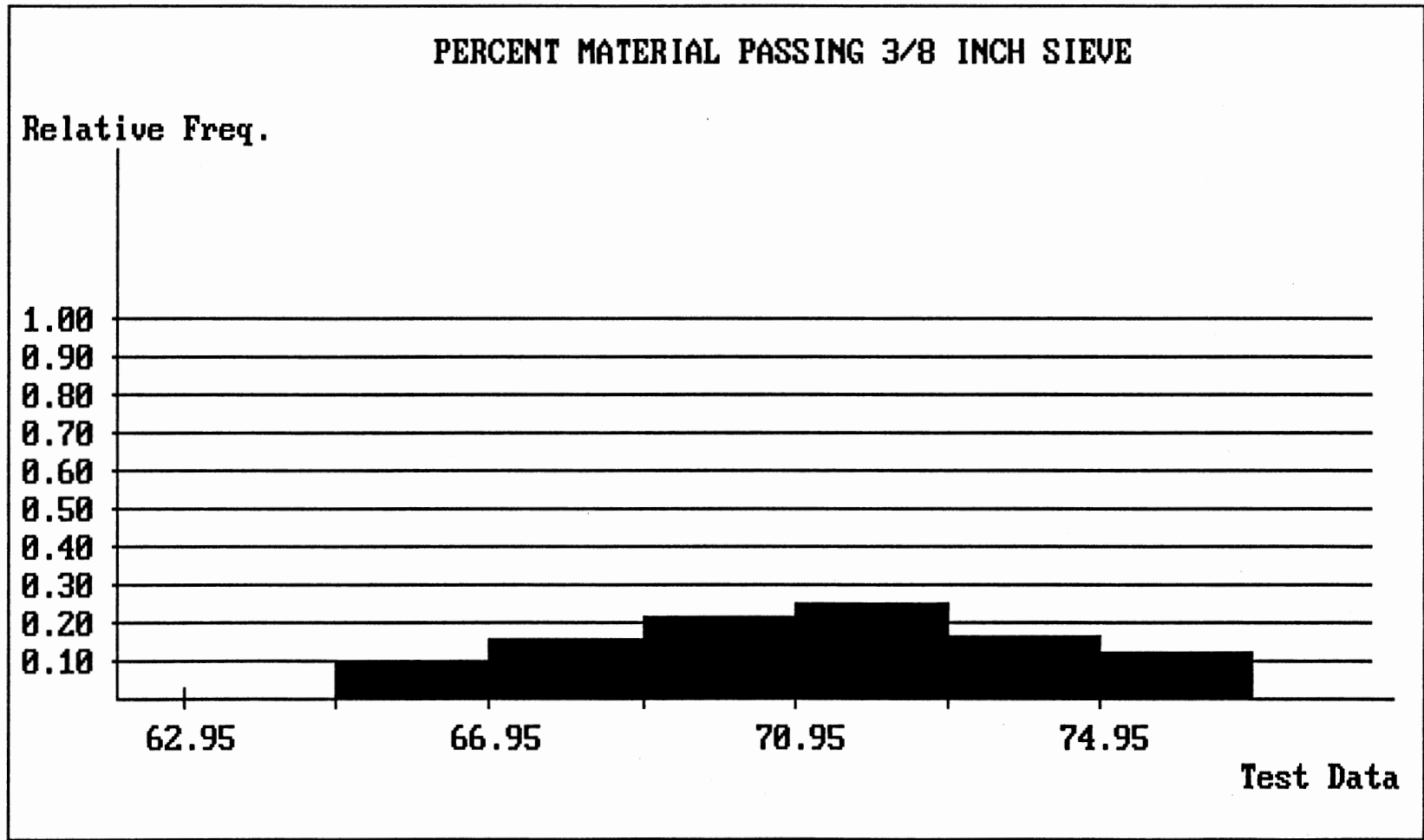

Figure 28. Relative Frequency Histogram

TABLE 13
POINT FREQUENCY TABLE

PERCENT MATERIAL PASSING 3/8 INCH SIEVE

Test Data	Frequency	Relative Freq.	Cumulative Freq.
65.00	1	0.012	0.012
65.10	1	0.012	0.024
65.30	1	0.012	0.036
65.50	1	0.012	0.048
66.00	1	0.012	0.060
66.50	1	0.012	0.071
66.80	2	0.024	0.095
67.30	1	0.012	0.107
67.40	1	0.012	0.119
67.50	1	0.012	0.131
67.60	1	0.012	0.143
67.70	2	0.024	0.167
67.90	2	0.024	0.190
68.00	2	0.024	0.214
68.50	1	0.012	0.226
68.70	1	0.012	0.238
68.80	1	0.012	0.250
69.00	2	0.024	0.274
69.20	2	0.024	0.298
69.30	1	0.012	0.310
69.40	2	0.024	0.333
69.80	1	0.012	0.345
70.00	1	0.012	0.357
70.10	1	0.012	0.369
70.30	1	0.012	0.381
70.40	1	0.012	0.393
70.50	1	0.012	0.405
70.60	1	0.012	0.417
70.70	3	0.036	0.452
70.90	1	0.012	0.464
71.00	1	0.012	0.476
71.10	2	0.024	0.500
71.20	1	0.012	0.512
71.30	1	0.012	0.524
71.40	2	0.024	0.548
71.60	1	0.012	0.560
71.70	3	0.036	0.595
72.10	2	0.024	0.619
72.20	2	0.024	0.643
72.30	2	0.024	0.667
72.40	1	0.012	0.679
72.50	1	0.012	0.690
72.70	2	0.024	0.714
73.00	1	0.012	0.726
73.20	2	0.024	0.750
73.60	2	0.024	0.774
73.70	1	0.012	0.786
73.80	2	0.024	0.810
74.00	1	0.012	0.821
74.20	3	0.036	0.857
74.60	1	0.012	0.869
74.70	1	0.012	0.881
75.00	1	0.012	0.893
75.40	1	0.012	0.905
75.90	1	0.012	0.917
76.00	1	0.012	0.929
76.10	1	0.012	0.940
76.20	1	0.012	0.952
76.30	1	0.012	0.964
76.40	1	0.012	0.976
76.50	2	0.024	1.000
Totals	84	1.000	

TABLE 14

INTERVAL FREQUENCY TABLE

PERCENT MATERIAL PASSING 3/8 INCH SIEVE

Interval	Frequency	Relative Freq.	Rel. Cumulative Freq.
62.95 < X ≤ 64.95	0	0.00	0.00
64.95 < X ≤ 66.95	8	0.10	0.10
66.95 < X ≤ 68.95	13	0.15	0.25
68.95 < X ≤ 70.95	18	0.21	0.46
70.95 < X ≤ 72.95	21	0.25	0.71
72.95 < X ≤ 74.95	14	0.17	0.88
74.95 < X ≤ 76.95	10	0.12	1.00
Totals	84	1.00	

TABLE 15
DESCRIPTIVE STATISTICS

PERCENT MATERIAL PASSING 3/8 INCH SIEVE

Xmax	Xmin	Midrange	Median	Mean	Range	Variance	S. Dev.	CV %
76.50	65.00	70.75	71.15	71.10	11.50	9.15	3.02	4.25

THE 15th Percentile is : 67.6

THE 50th Percentile is : 71.1

THE 85th Percentile is : 74.2

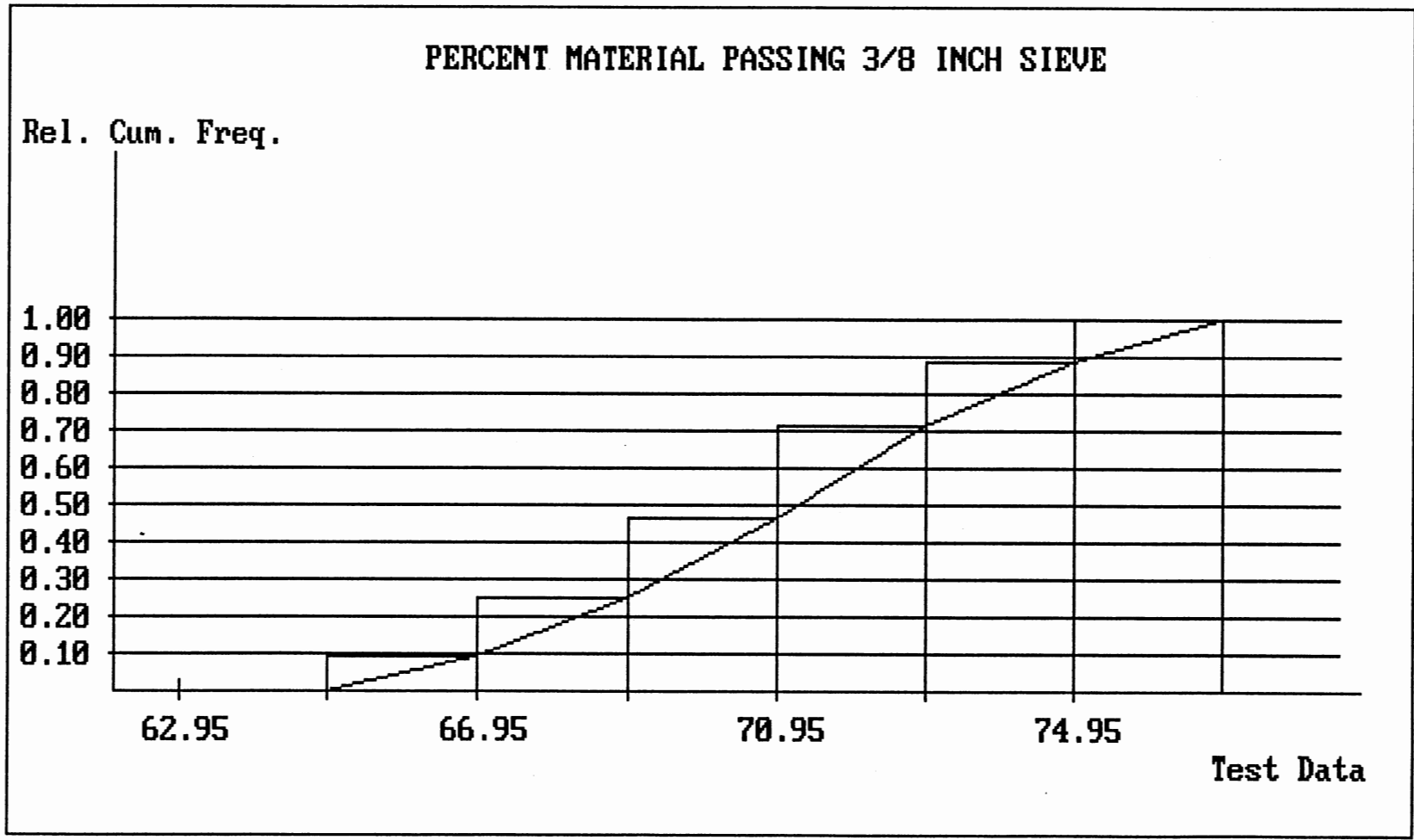

Figure 29. Cumulative Frequency Curve

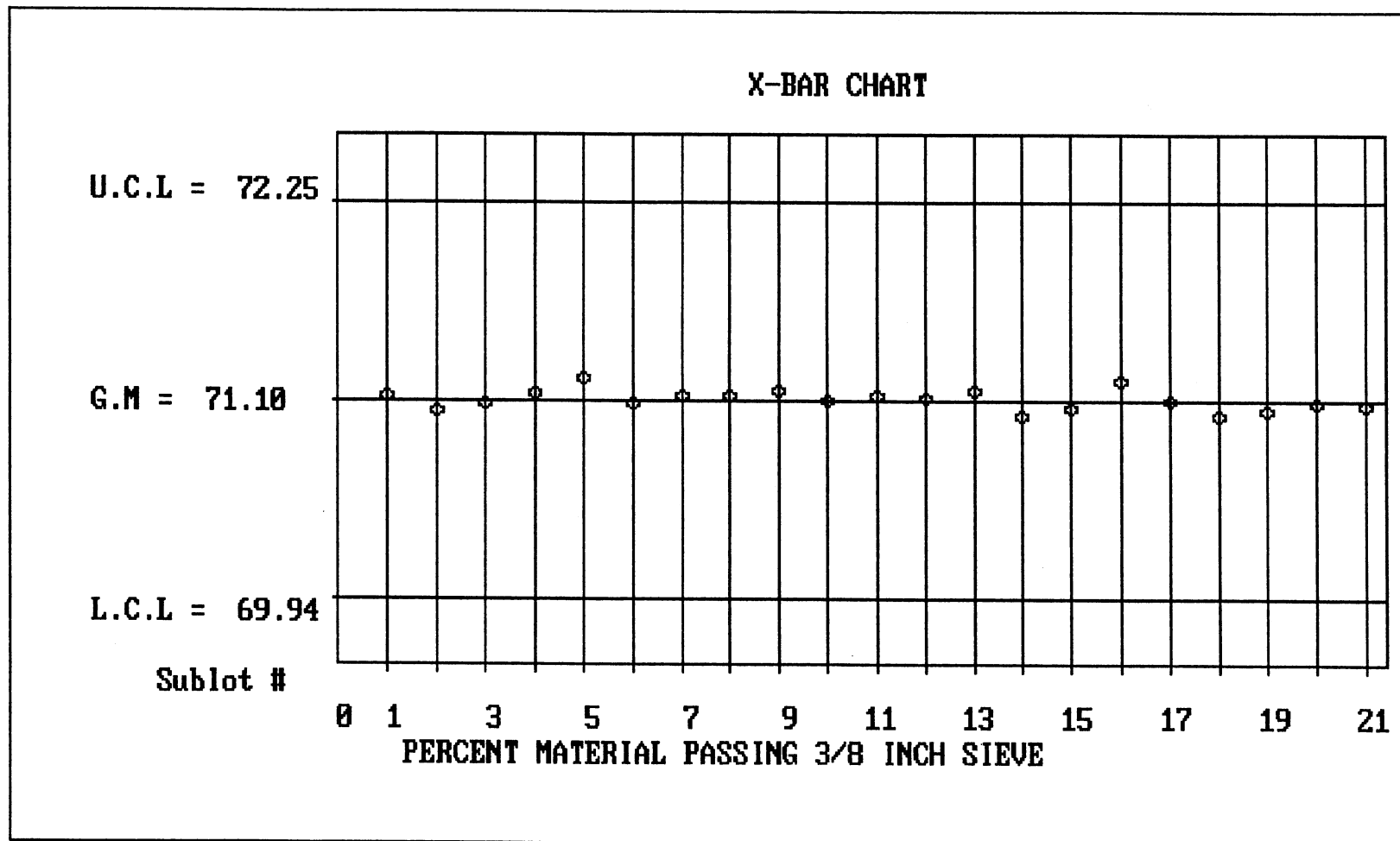

Figure 30. XBAR Control Chart

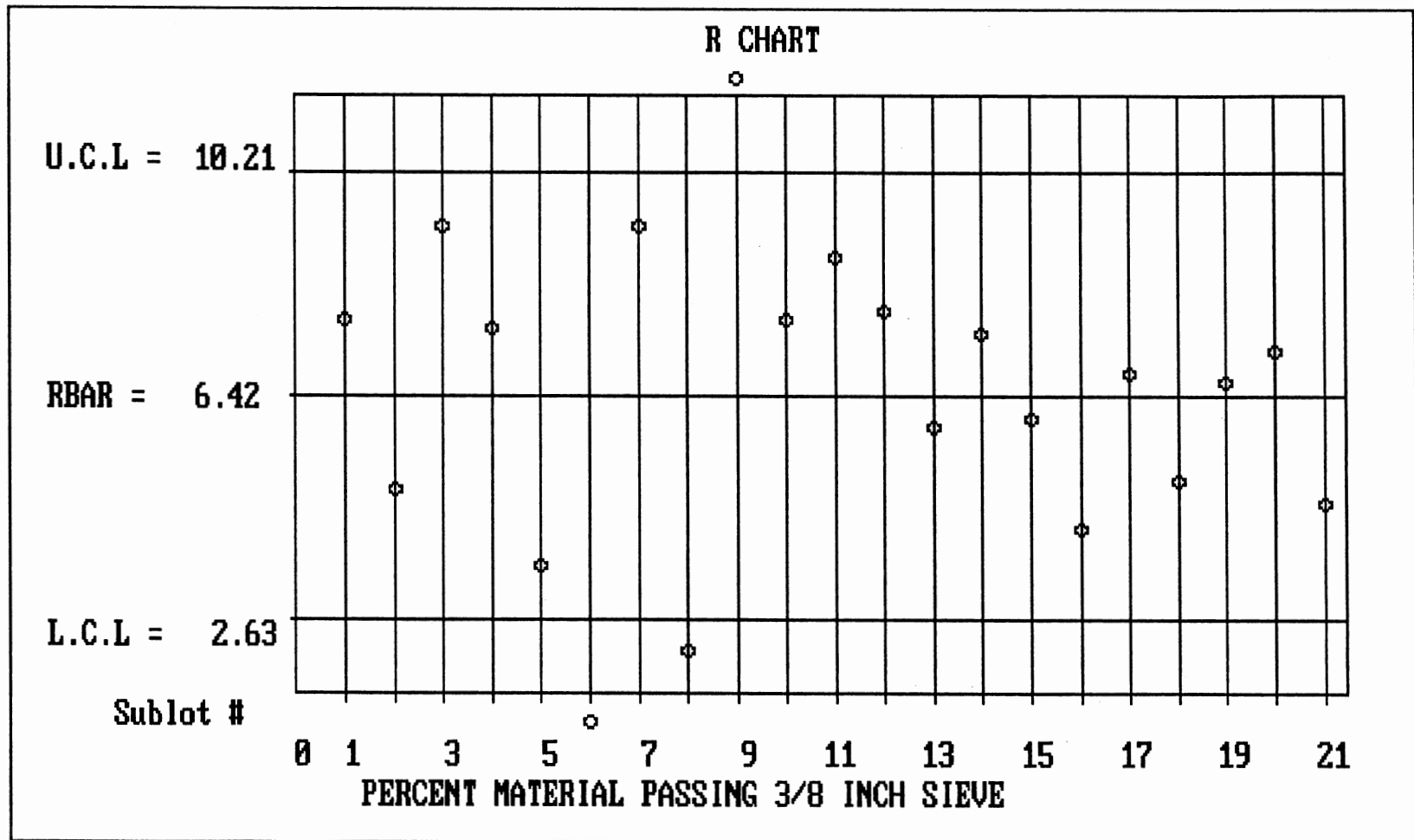

Figure 31. R Control Chart

TABLE 16
NESTED ANALYSIS OF VARIANCE

PERCENT MATERIAL PASSING 3/8 INCH SIEVE

21 Sublots,
2 Sample Units per Sublot,
2 Test Specimens per Sample Unit

Source of Variation	Sum of Squares	d.f.	Mean Square, M.S.	Expected M.S.
Between Sublots	212.520	20	10.626	$\sigma_T^2 + 2\sigma_S^2 + 4\sigma_M^2$
Between Sample Units	252.008	21	12.000	$\sigma_T^2 + 2\sigma_S^2$
Between Tests	294.590	42	7.014	σ_T^2
Total	759.118	83		

Component	Variance		Percent of Total Variance	
	Computed	Rounded	Computed	Rounded
Material	-0.3436	0.0000	-3.75	0.00
Sampling	2.4932	2.4932	27.21	26.22
Testing	7.0140	7.0140	76.54	73.78
Total	9.1636	9.1636	100.00	100.00

Hypothesis 1	Computed F-Ratio	Hypothesis 2	Computed F-Ratio
$H_0: \sigma_M^2 = 0$	0.89	$H_0: \sigma_S^2 = 0$	1.71
$H_1: \sigma_M^2 > 0$		$H_1: \sigma_S^2 > 0$	

APPENDIX B

NANOVA REPORTS FOR NESTED ANALYSIS

OF VARIANCE

US 412 PROJECT, MIXTURE ANALYSIS - SIEVE: 1 1/2 inch
 23 Sublots,
 2 Sample Units per Sublot,
 2 Test Specimens per Sample Unit

Source of Variation	Sum of Squares	d.f.	Mean Square, M.S.	Expected M.S.
Between Sublots	0.000	22	0.000	$\sigma_T^2 + 2 \sigma_S^2 + 4 \sigma_M^2$
Between Sample Units	0.000	23	0.000	$\sigma_T^2 + 2 \sigma_S^2$
Between Tests	0.000	46	0.000	σ_T^2
Total	0.000	91		

Component	Variance		Percent of Total Variance	
	Computed	Rounded	Computed	Rounded
Material	0.00	0.00	0.00	0.00
Sampling	0.00	0.00	0.00	0.00
Testing	0.00	0.00	0.00	0.00
Total	0.00	0.00	0.00	0.00

Hypothesis 1	Computed F-Ratio	Hypothesis 2	Computed F-Ratio
$H_0: \sigma_M^2 = 0$	0.00	$H_0: \sigma_S^2 = 0$	0.00
$H_1: \sigma_M^2 > 0$		$H_1: \sigma_S^2 > 0$	

US 412 PROJECT, MIXTURE ANALYSIS - SIEVE: 1 inch
 23 Sublots,
 2 Sample Units per Sublot,
 2 Test Specimens per Sample Unit

Source of Variation	Sum of Squares	d.f.	Mean Square, M.S.	Expected M.S.
Between Sublots	71.913	22	3.269	$\sigma_T^2 + 2 \sigma_S^2 + 4 \sigma_M^2$
Between Sample Units	57.967	23	2.520	$\sigma_T^2 + 2 \sigma_S^2$
Between Tests	129.709	46	2.820	σ_T^2
Total	259.590	91		

Component	Variance		Percent of Total Variance	
	Computed	Rounded	Computed	Rounded
Material	0.1871	0.1871	6.55	6.22
Sampling	-0.1497	0.0000	-5.24	0.00
Testing	2.8198	2.8198	98.69	93.78
Total	2.8572	3.0069	100.00	100.00

Hypothesis 1	Computed F-Ratio	Hypothesis 2	Computed F-Ratio
$H_0: \sigma_M^2 = 0$	1.30	$H_0: \sigma_S^2 = 0$	0.89
$H_1: \sigma_M^2 > 0$		$H_1: \sigma_S^2 > 0$	

US 412 PROJECT, MIXTURE ANALYSIS - SIEVE: 3/4 inch
 23 Sublots,
 2 Sample Units per Sublot,
 2 Test Specimens per Sample Unit

Source of Variation	Sum of Squares	d.f.	Mean Square, M.S.	Expected M.S.
Between Sublots	487.869	22	22.176	$\sigma_T^2 + 2 \sigma_S^2 + 4 \sigma_M^2$
Between Sample Units	246.080	23	10.669	$\sigma_T^2 + 2 \sigma_S^2$
Between Tests	652.621	46	14.187	σ_T^2
Total	1386.569	91		

Component	Variance		Percent of Total Variance	
	Computed	Rounded	Computed	Rounded
Material	2.8692	2.8692	18.74	16.82
Sampling	-1.7441	0.0000	-11.39	0.00
Testing	14.1874	14.1874	92.65	83.18
Total	15.3124	17.0566	100.00	100.00

Hypothesis 1	Computed F-Ratio	Hypothesis 2	Computed F-Ratio
$H_0: \sigma_M^2 = 0$	2.07	$H_0: \sigma_S^2 = 0$	0.75
$H_1: \sigma_M^2 > 0$		$H_1: \sigma_S^2 > 0$	

US 412 PROJECT, MIXTURE ANALYSIS - SIEVE: 1/2 inch
 23 Sublots,
 2 Sample Units per Sublot,
 2 Test Specimens per Sample Unit

Source of Variation	Sum of Squares	d.f.	Mean Square, M.S.	Expected M.S.
Between Sublots	622.239	22	28.284	$\sigma_T^2 + 2 \sigma_S^2 + 4 \sigma_M^2$
Between Sample Units	544.888	23	23.691	$\sigma_T^2 + 2 \sigma_S^2$
Between Tests	667.359	46	14.508	σ_T^2
Total	1834.486	91		

Component	Variance		Percent of Total Variance	
	Computed	Rounded	Computed	Rounded
Material	1.1482	1.1482	5.67	5.67
Sampling	4.5915	4.5915	22.68	22.68
Testing	14.5078	14.5078	71.65	71.65
Total	20.2475	20.2475	100.00	100.00

Hypothesis 1	Computed F-Ratio	Hypothesis 2	Computed F-Ratio
$H_0: \sigma_M^2 = 0$	1.19	$H_0: \sigma_S^2 = 0$	1.63
$H_1: \sigma_M^2 > 0$		$H_1: \sigma_S^2 > 0$	

US 412 PROJECT, MIXTURE ANALYSIS - SIEVE: 3/8 inch

23 Sublots,

2 Sample Units per Sublot,

2 Test Specimens per Sample Unit

Source of Variation	Sum of Squares	d.f.	Mean Square, M.S.	Expected M.S.
Between Sublots	779.925	22	35.451	$\sigma_T^2 + 2 \sigma_S^2 + 4 \sigma_M^2$
Between Sample Units	537.683	23	23.378	$\sigma_T^2 + 2 \sigma_S^2$
Between Tests	631.691	46	13.732	σ_T^2
Total	1949.299	91		

Component	Variance		Percent of Total Variance	
	Computed	Rounded	Computed	Rounded
Material	3.0184	3.0184	13.99	13.99
Sampling	4.8226	4.8226	22.35	22.35
Testing	13.7324	13.7324	63.65	63.65
Total	21.5734	21.5734	100.00	100.00

Hypothesis 1	Computed F-Ratio	Hypothesis 2	Computed F-Ratio
$H_0: \sigma_M^2 = 0$	1.52	$H_0: \sigma_S^2 = 0$	1.70
$H_1: \sigma_M^2 > 0$		$H_1: \sigma_S^2 > 0$	

US 412 PROJECT, MIXTURE ANALYSIS - SIEVE: No. 4

23 Sublots,

2 Sample Units per Sublot,

2 Test Specimens per Sample Unit

Source of Variation	Sum of Squares	d.f.	Mean Square, M.S.	Expected M.S.
Between Sublots	497.372	22	22.608	$\sigma_T^2 + 2 \sigma_S^2 + 4 \sigma_M^2$
Between Sample Units	271.994	23	11.826	$\sigma_T^2 + 2 \sigma_S^2$
Between Tests	219.144	46	4.764	σ_T^2
Total	988.509	91		

Component	Variance		Percent of Total Variance	
	Computed	Rounded	Computed	Rounded
Material	2.6955	2.6955	24.53	24.53
Sampling	3.5309	3.5309	32.13	32.13
Testing	4.7640	4.7640	43.35	43.35
Total	10.9904	10.9904	100.00	100.100

Hypothesis 1	Computed F-Ratio	Hypothesis 2	Computed F-Ratio
$H_0: \sigma_M^2 = 0$	1.91	$H_0: \sigma_S^2 = 0$	2.48
$H_1: \sigma_M^2 > 0$		$H_1: \sigma_S^2 > 0$	

US 412 PROJECT, MIXTURE ANALYSIS - SIEVE: No. 10

23 Sublots,

2 Sample Units per Sublot,

2 Test Specimens per Sample Unit

Source of Variation	Sum of Squares	d.f.	Mean Square, M.S.	Expected M.S.
Between Sublots	246.671	22	11.212	$\sigma_T^2 + 2 \sigma_S^2 + 4 \sigma_M^2$
Between Sample Units	83.921	23	3.649	$\sigma_T^2 + 2 \sigma_S^2$
Between Tests	78.975	46	1.717	σ_T^2
Total	409.567	91		

Component	Variance		Percent of Total Variance	
	Computed	Rounded	Computed	Rounded
Material	1.8909	1.8909	41.34	41.34
Sampling	0.9660	0.9660	21.12	21.12
Testing	1.7168	1.7168	37.54	37.54
Total	4.5737	4.5737	100.00	100.00

Hypothesis 1	Computed F-Ratio	Hypothesis 2	Computed F-Ratio
$H_0: \sigma_M^2 = 0$	3.07	$H_0: \sigma_S^2 = 0$	2.13
$H_1: \sigma_M^2 > 0$		$H_1: \sigma_S^2 > 0$	

US 412 PROJECT, MIXTURE ANALYSIS - SIEVE: No. 40

23 Sublots,

2 Sample Units per Sublot,

2 Test Specimens per Sample Unit

Source of Variation	Sum of Squares	d.f.	Mean Square, M.S.	Expected M.S.
Between Sublots	110.245	22	5.011	$\sigma_T^2 + 2 \sigma_S^2 + 4 \sigma_M^2$
Between Sample Units	26.147	23	1.137	$\sigma_T^2 + 2 \sigma_S^2$
Between Tests	24.165	46	0.525	σ_T^2
Total	160.557	91		

Component	Variance		Percent of Total Variance	
	Computed	Rounded	Computed	Rounded
Material	0.9686	0.9686	53.82	53.82
Sampling	0.3058	0.3058	16.99	16.99
Testing	0.5253	0.5253	29.19	29.19
Total	1.7997	1.7997	100.00	100.00

Hypothesis 1	Computed F-Ratio	Hypothesis 2	Computed F-Ratio
$H_0: \sigma_M^2 = 0$	4.41	$H_0: \sigma_S^2 = 0$	2.16
$H_1: \sigma_M^2 > 0$		$H_1: \sigma_S^2 > 0$	

US 412 PROJECT, MIXTURE ANALYSIS - SIEVE: No. 80

23 Sublots,

2 Sample Units per Sublot,

2 Test Specimens per Sample Unit

Source of Variation	Sum of Squares	d.f.	Mean Square, M.S.	Expected M.S.
Between Sublots	34.434	22	1.565	$\sigma_T^2 + 2 \sigma_S^2 + 4 \sigma_M^2$
Between Sample Units	11.463	23	0.498	$\sigma_T^2 + 2 \sigma_S^2$
Between Tests	6.705	46	0.146	σ_T^2
Total	52.602	91		

Component	Variance		Percent of Total Variance	
	Computed	Rounded	Computed	Rounded
Material	0.2667	0.2667	45.30	45.30
Sampling	0.1763	0.1763	29.94	29.94
Testing	0.1458	0.1458	24.76	24.76
Total	0.5888	0.5888	100.00	100.00

Hypothesis 1	Computed F-Ratio	Hypothesis 2	Computed F-Ratio
$H_0: \sigma_M^2 = 0$	3.14	$H_0: \sigma_S^2 = 0$	3.42
$H_1: \sigma_M^2 > 0$		$H_1: \sigma_S^2 > 0$	

US 412 PROJECT, MIXTURE ANALYSIS - SIEVE: No. 200

23 Sublots,

2 Sample Units per Sublot,

2 Test Specimens per Sample Unit

Source of Variation	Sum of Squares	d.f.	Mean Square, M.S.	Expected M.S.
Between Sublots	22.626	22	1.028	$\sigma_T^2 + 2 \sigma_S^2 + 4 \sigma_M^2$
Between Sample Units	6.523	23	0.284	$\sigma_T^2 + 2 \sigma_S^2$
Between Tests	2.760	46	0.060	σ_T^2
Total	31.909	91		

Component	Variance		Percent of Total Variance	
	Computed	Rounded	Computed	Rounded
Material	0.1862	0.1862	52.01	52.01
Sampling	0.1118	0.1118	31.23	31.23
Testing	0.0600	0.0600	16.76	16.76
Total	0.3580	0.3580	100.00	100.00

Hypothesis 1	Computed F-Ratio	Hypothesis 2	Computed F-Ratio
$H_0: \sigma_M^2 = 0$	3.63	$H_0: \sigma_S^2 = 0$	4.73
$H_1: \sigma_M^2 > 0$		$H_1: \sigma_S^2 > 0$	

US 412 PROJECT, MIXTURE ANALYSIS - % AC (EXTRACTION)

23 Sublots,

2 Sample Units per Sublot,

2 Test Specimens per Sample Unit

Source of Variation	Sum of Squares	d.f.	Mean Square, M.S.	Expected M.S.
Between Sublots	4.956	22	0.225	$\sigma_T^2 + 2 \sigma_S^2 + 4 \sigma_M^2$
Between Sample Units	1.671	23	0.073	$\sigma_T^2 + 2 \sigma_S^2$
Between Tests	1.729	46	0.038	σ_T^2
Total	8.356	91		

Component	Variance		Percent of Total Variance	
	Computed	Rounded	Computed	Rounded
Material	0.0382	0.0382	40.91	40.91
Sampling	0.0175	0.0175	18.80	18.80
Testing	0.0376	0.0376	40.29	40.29
Total	0.0933	0.0933	100.00	100.00

Hypothesis 1	Computed F-Ratio	Hypothesis 2	Computed F-Ratio
$H_0: \sigma_M^2 = 0$	3.10	$H_0: \sigma_S^2 = 0$	1.93
$H_1: \sigma_M^2 > 0$		$H_1: \sigma_S^2 > 0$	

US 412 PROJECT, MIXTURE ANALYSIS - % AC (NUCLEAR)

22 Sublots,

2 Sample Units per Sublot,

2 Test Specimens per Sample Unit

Source of Variation	Sum of Squares	d.f.	Mean Square, M.S.	Expected M.S.
Between Sublots	8.431	21	0.401	$\sigma_T^2 + 2 \sigma_S^2 + 4 \sigma_M^2$
Between Sample Units	1.335	22	0.061	$\sigma_T^2 + 2 \sigma_S^2$
Between Tests	0.823	44	0.019	σ_T^2
Total	10.589	87		

Component	Variance		Percent of Total Variance	
	Computed	Rounded	Computed	Rounded
Material	0.0852	0.0852	68.22	68.22
Sampling	0.0210	0.0210	16.80	16.80
Testing	0.0187	0.0187	14.98	14.98
Total	0.1249	0.1249	100.00	100.00

Hypothesis 1	Computed F-Ratio	Hypothesis 2	Computed F-Ratio
$H_0: \sigma_M^2 = 0$	6.62	$H_0: \sigma_S^2 = 0$	3.24
$H_1: \sigma_M^2 > 0$		$H_1: \sigma_S^2 > 0$	

US 412 PROJECT, MIXTURE ANALYSIS - CORE DENSITY

25 Sublots,

2 Sample Units per Sublot,

2 Test Specimens per Sample Unit

Source of Variation	Sum of Squares	d.f.	Mean Square, M.S.	Expected M.S.
Between Sublots	60.534	24	2.522	$\sigma_T^2 + 2 \sigma_S^2 + 4 \sigma_M^2$
Between Sample Units	37.113	25	1.485	$\sigma_T^2 + 2 \sigma_S^2$
Between Tests	10.893	50	0.218	σ_T^2
Total	108.540	99		

Component	Variance		Percent of Total Variance	
	Computed	Rounded	Computed	Rounded
Material	0.2594	0.2594	23.36	23.36
Sampling	0.6333	0.6333	57.03	57.03
Testing	0.2179	0.2179	19.62	19.62
Total	1.1106	1.1106	100.00	100.00

Hypothesis 1	Computed F-Ratio	Hypothesis 2	Computed F-Ratio
$H_0: \sigma_M^2 = 0$	1.70	$H_0: \sigma_S^2 = 0$	6.81
$H_1: \sigma_M^2 > 0$		$H_1: \sigma_S^2 > 0$	

US 412 PROJECT, MIXTURE ANALYSIS - NUCLEAR DENSITY

25 Sublots,

2 Sample Units per Sublot,

2 Test Specimens per Sample Unit

Source of Variation	Sum of Squares	d.f.	Mean Square, M.S.	Expected M.S.
Between Sublots	320.091	24	13.337	$\sigma_T^2 + 2 \sigma_S^2 + 4 \sigma_M^2$
Between Sample Units	114.087	25	4.563	$\sigma_T^2 + 2 \sigma_S^2$
Between Tests	53.048	50	1.061	σ_T^2
Total	487.226	99		

Component	Variance		Percent of Total Variance	
	Computed	Rounded	Computed	Rounded
Material	2.1934	2.1934	43.82	43.82
Sampling	1.7513	1.7513	34.99	34.99
Testing	1.0610	1.0610	21.20	21.20
Total	5.0056	5.0056	100.00	100.00

Hypothesis 1	Computed F-Ratio	Hypothesis 2	Computed F-Ratio
$H_0: \sigma_M^2 = 0$	2.92	$H_0: \sigma_S^2 = 0$	4.30
$H_1: \sigma_M^2 > 0$		$H_1: \sigma_S^2 > 0$	

US 412 PROJECT, MIXTURE ANALYSIS - AVERAGE RICES

23 Sublots,

2 Sample Units per Sublot,

2 Test Specimens per Sample Unit

Source of Variation	Sum of Squares	d.f.	Mean Square, M.S.	Expected M.S.
Between Sublots	0.245	22	0.011	$\sigma_T^2 + 2 \sigma_S^2 + 4 \sigma_M^2$
Between Sample Units	0.278	23	0.012	$\sigma_T^2 + 2 \sigma_S^2$
Between Tests	0.503	46	0.011	σ_T^2
Total	1.025	91		

Component	Variance		Percent of Total Variance	
	Computed	Rounded	Computed	Rounded
Material	-0.0002	0.0000	-2.12	0.00
Sampling	0.0006	0.0006	5.04	4.93
Testing	0.0109	0.0109	97.09	95.07
Total	0.0113	0.0115	100.00	100.00

Hypothesis 1	Computed F-Ratio	Hypothesis 2	Computed F-Ratio
$H_0: \sigma_M^2 = 0$	0.92	$H_0: \sigma_S^2 = 0$	1.10
$H_1: \sigma_M^2 > 0$		$H_1: \sigma_S^2 > 0$	

US 412 PROJECT, MIXTURE ANALYSIS - SPECIFIC GRAVITY

22 Sublots,

2 Sample Units per Sublot,

2 Test Specimens per Sample Unit

Source of Variation	Sum of Squares	d.f.	Mean Square, M.S.	Expected M.S.
Between Sublots	0.070	21	0.003	$\sigma_T^2 + 2 \sigma_S^2 + 4 \sigma_M^2$
Between Sample Units	0.022	22	0.001	$\sigma_T^2 + 2 \sigma_S^2$
Between Tests	0.003	44	0.000	σ_T^2
Total	0.096	87		

Component	Variance		Percent of Total Variance	
	Computed	Rounded	Computed	Rounded
Material	0.0006	0.0006	51.92	51.92
Sampling	0.0005	0.0005	42.21	42.21
Testing	0.0001	0.0001	5.87	5.87
Total	0.0012	0.0012	100.00	100.00

Hypothesis 1	Computed F-Ratio	Hypothesis 2	Computed F-Ratio
$H_0: \sigma_M^2 = 0$	3.30	$H_0: \sigma_S^2 = 0$	15.39
$H_1: \sigma_M^2 > 0$		$H_1: \sigma_S^2 > 0$	

US 412 PROJECT, MIXTURE ANALYSIS - % AIR VOIDS

22 Sublots,

2 Sample Units per Sublot,

2 Test Specimens per Sample Unit

Source of Variation	Sum of Squares	d.f.	Mean Square, M.S.	Expected M.S.
Between Sublots	180.073	21	8.575	$\sigma_T^2 + 2 \sigma_S^2 + 4 \sigma_M^2$
Between Sample Units	52.581	22	2.390	$\sigma_T^2 + 2 \sigma_S^2$
Between Tests	12.838	44	0.292	σ_T^2
Total	245.492	87		

Component	Variance		Percent of Total Variance	
	Computed	Rounded	Computed	Rounded
Material	1.5462	1.5462	53.56	53.56
Sampling	1.0491	1.0491	36.34	36.34
Testing	0.2918	0.2918	10.11	10.11
Total	2.8871	2.8871	100.00	100.00

Hypothesis 1	Computed F-Ratio	Hypothesis 2	Computed F-Ratio
$H_0: \sigma_M^2 = 0$	3.59	$H_0: \sigma_S^2 = 0$	8.19
$H_1: \sigma_M^2 > 0$		$H_1: \sigma_S^2 > 0$	

US 412 PROJECT, MIXTURE ANALYSIS - AVERAGE STABILITY

17 Sublots,
 2 Sample Units per Sublot,
 2 Test Specimens per Sample Unit

Source of Variation	Sum of Squares	d.f.	Mean Square, M.S.	Expected M.S.
Between Sublots	1544.653	16	96.541	$\sigma_T^2 + 2 \sigma_S^2 + 4 \sigma_M^2$
Between Sample Units	245.796	17	14.459	$\sigma_T^2 + 2 \sigma_S^2$
Between Tests	147.814	34	4.347	σ_T^2
Total	1938.263	67		

Component	Variance		Percent of Total Variance	
	Computed	Rounded	Computed	Rounded
Material	20.5205	20.5205	68.58	68.58
Sampling	5.0556	5.0556	16.89	16.89
Testing	4.3475	4.3475	14.53	14.53
Total	29.9236	29.9236	100.00	100.00

Hypothesis 1	Computed F-Ratio	Hypothesis 2	Computed F-Ratio
$H_0: \sigma_M^2 = 0$	6.68	$H_0: \sigma_S^2 = 0$	3.33
$H_1: \sigma_M^2 > 0$		$H_1: \sigma_S^2 > 0$	

US 412 PROJECT, AGGREGATE ANALYSIS - SIEVE: 1 1/2 inch
 23 Sublots,
 2 Sample Units per Sublot,
 2 Test Specimens per Sample Unit

Source of Variation	Sum of Squares	d.f.	Mean Square, M.S.	Expected M.S.
Between Sublots	0.000	22	0.000	$\sigma_T^2 + 2 \sigma_S^2 + 4 \sigma_M^2$
Between Sample Units	0.000	23	0.000	$\sigma_T^2 + 2 \sigma_S^2$
Between Tests	0.000	46	0.000	σ_T^2
Total	0.000	91		

Component	Variance		Percent of Total Variance	
	Computed	Rounded	Computed	Rounded
Material	0.0000	0.0000	0.00	0.00
Sampling	0.0000	0.0000	0.00	0.00
Testing	0.0000	0.0000	0.00	0.00
Total	0.0000	0.0000	0.00	0.00

Hypothesis 1	Computed F-Ratio	Hypothesis 2	Computed F-Ratio
$H_0: \sigma_M^2 = 0$	0.00	$H_0: \sigma_S^2 = 0$	0.00
$H_1: \sigma_M^2 > 0$		$H_1: \sigma_S^2 > 0$	

US 412 PROJECT, AGGREGATE ANALYSIS - SIEVE: 1 inch

23 Sublots,

2 Sample Units per Sublot,

2 Test Specimens per Sample Unit

Source of Variation	Sum of Squares	d.f.	Mean Square, M.S.	Expected M.S.
Between Sublots	51.738	22	2.352	$\sigma_T^2 + 2 \sigma_S^2 + 4 \sigma_M^2$
Between Sample Units	24.926	23	1.084	$\sigma_T^2 + 2 \sigma_S^2$
Between Tests	49.808	46	1.083	σ_T^2
Total	126.472	91		

Component	Variance		Percent of Total Variance	
	Computed	Rounded	Computed	Rounded
Material	0.3170	0.3170	22.64	22.64
Sampling	0.0005	0.0005	0.03	0.03
Testing	1.0828	1.0828	77.33	77.33
Total	1.4003	1.4003	100.00	100.00

Hypothesis 1	Computed F-Ratio	Hypothesis 2	Computed F-Ratio
$H_0: \sigma_M^2 = 0$	2.17	$H_0: \sigma_S^2 = 0$	1.00
$H_1: \sigma_M^2 > 0$		$H_1: \sigma_S^2 > 0$	

US 412 PROJECT, AGGREGATE ANALYSIS - SIEVE: 3/4 inch
 23 Sublots,
 2 Sample Units per Sublot,
 2 Test Specimens per Sample Unit

Source of Variation	Sum of Squares	d.f.	Mean Square, M.S.	Expected M.S.
Between Sublots	284.322	22	12.924	$\sigma_T^2 + 2 \sigma_S^2 + 4 \sigma_M^2$
Between Sample Units	149.913	23	6.518	$\sigma_T^2 + 2 \sigma_S^2$
Between Tests	260.108	46	5.655	σ_T^2
Total	694.343	91		

Component	Variance		Percent of Total Variance	
	Computed	Rounded	Computed	Rounded
Material	1.6014	1.6014	20.83	20.83
Sampling	0.4317	0.4317	5.62	5.62
Testing	5.6545	5.6545	73.55	73.55
Total	7.6877	7.6877	100.00	100.00

Hypothesis 1	Computed F-Ratio	Hypothesis 2	Computed F-Ratio
$H_0: \sigma_M^2 = 0$	1.98	$H_0: \sigma_S^2 = 0$	1.15
$H_1: \sigma_M^2 > 0$		$H_1: \sigma_S^2 > 0$	

US 412 PROJECT, AGGREGATE ANALYSIS - SIEVE: 1/2 inch

23 Sublots,

2 Sample Units per Sublot,

2 Test Specimens per Sample Unit

Source of Variation	Sum of Squares	d.f.	Mean Square, M.S.	Expected M.S.
Between Sublots	701.040	22	31.865	$\sigma_T^2 + 2 \sigma_S^2 + 4 \sigma_M^2$
Between Sample Units	234.363	23	10.190	$\sigma_T^2 + 2 \sigma_S^2$
Between Tests	779.953	46	16.955	σ_T^2
Total	1715.356	91		

Component	Variance		Percent of Total Variance	
	Computed	Rounded	Computed	Rounded
Material	5.4189	5.4189	28.53	24.22
Sampling	-3.3829	0.0000	-17.81	0.00
Testing	16.9555	16.9555	89.28	75.78
Total	18.9915	22.3744	100.00	100.00

Hypothesis 1	Computed F-Ratio	Hypothesis 2	Computed F-Ratio
$H_0: \sigma_M^2 = 0$	3.13	$H_0: \sigma_S^2 = 0$	0.60
$H_1: \sigma_M^2 > 0$		$H_1: \sigma_S^2 > 0$	

US 412 PROJECT, AGGREGATE ANALYSIS - SIEVE: 3/8 inch

23 Sublots,

2 Sample Units per Sublot,

2 Test Specimens per Sample Unit

Source of Variation	Sum of Squares	d.f.	Mean Square, M.S.	Expected M.S.
Between Sublots	606.830	22	27.583	$\sigma_T^2 + 2 \sigma_S^2 + 4 \sigma_M^2$
Between Sample Units	210.105	23	9.135	$\sigma_T^2 + 2 \sigma_S^2$
Between Tests	930.616	46	20.231	σ_T^2
Total	1747.551	91		

Component	Variance		Percent of Total Variance	
	Computed	Rounded	Computed	Rounded
Material	4.6121	4.6121	23.90	18.56
Sampling	-5.5479	0.0000	-28.75	0.00
Testing	20.2308	20.2308	104.85	81.44
Total	19.2949	24.8421	100.00	100.00

Hypothesis 1	Computed F-Ratio	Hypothesis 2	Computed F-Ratio
$H_0: \sigma_M^2 = 0$	3.02	$H_0: \sigma_S^2 = 0$	0.45
$H_1: \sigma_M^2 > 0$		$H_1: \sigma_S^2 > 0$	

US 412 PROJECT, AGGREGATE ANALYSIS - SIEVE: No. 4

23 Sublots,

2 Sample Units per Sublot,

2 Test Specimens per Sample Unit

Source of Variation	Sum of Squares	d.f.	Mean Square, M.S.	Expected M.S.
Between Sublots	310.023	22	14.092	$\sigma_T^2 + 2 \sigma_S^2 + 4 \sigma_M^2$
Between Sample Units	144.903	23	6.300	$\sigma_T^2 + 2 \sigma_S^2$
Between Tests	648.801	46	14.104	σ_T^2
Total	1103.727	91		

Component	Variance		Percent of Total Variance	
	Computed	Rounded	Computed	Rounded
Material	1.9480	1.9480	16.03	12.14
Sampling	-3.9021	0.0000	-32.12	0.00
Testing	14.1044	14.1044	116.08	87.86
Total	12.1502	16.0524	100.00	100.00

Hypothesis 1	Computed F-Ratio	Hypothesis 2	Computed F-Ratio
$H_0: \sigma_M^2 = 0$	2.24	$H_0: \sigma_S^2 = 0$	0.45
$H_1: \sigma_M^2 > 0$		$H_1: \sigma_S^2 > 0$	

US 412 PROJECT, AGGREGATE ANALYSIS - SIEVE: No. 10

23 Sublots,

2 Sample Units per Sublot,

2 Test Specimens per Sample Unit

Source of Variation	Sum of Squares	d.f.	Mean Square, M.S.	Expected M.S.
Between Sublots	202.694	22	9.213	$\sigma_T^2 + 2 \sigma_S^2 + 4 \sigma_M^2$
Between Sample Units	153.914	23	6.692	$\sigma_T^2 + 2 \sigma_S^2$
Between Tests	432.114	46	9.394	σ_T^2
Total	788.722	91		

Component	Variance		Percent of Total Variance	
	Computed	Rounded	Computed	Rounded
Material	0.6304	0.6304	7.27	6.29
Sampling	-1.3509	0.0000	-15.58	0.00
Testing	9.3938	9.3938	108.31	93.71
Total	8.6732	10.0242	100.00	100.00

Hypothesis 1	Computed F-Ratio	Hypothesis 2	Computed F-Ratio
$H_0: \sigma_M^2 = 0$	1.38	$H_0: \sigma_S^2 = 0$	0.71
$H_1: \sigma_M^2 > 0$		$H_1: \sigma_S^2 > 0$	

US 412 PROJECT, AGGREGATE ANALYSIS - SIEVE: No. 40

23 Sublots,

2 Sample Units per Sublot,

2 Test Specimens per Sample Unit

Source of Variation	Sum of Squares	d.f.	Mean Square, M.S.	Expected M.S.
Between Sublots	89.544	22	4.070	$\sigma_T^2 + 2 \sigma_S^2 + 4 \sigma_M^2$
Between Sample Units	50.162	23	2.181	$\sigma_T^2 + 2 \sigma_S^2$
Between Tests	161.195	46	3.504	σ_T^2
Total	300.901	91		

Component	Variance		Percent of Total Variance	
	Computed	Rounded	Computed	Rounded
Material	0.4723	0.4723	14.25	11.88
Sampling	-0.6616	0.0000	-19.96	0.00
Testing	3.5042	3.5042	105.71	88.12
Total	3.3149	3.9765	100.00	100.00

Hypothesis 1	Computed F-Ratio	Hypothesis 2	Computed F-Ratio
$H_0: \sigma_M^2 = 0$	1.87	$H_0: \sigma_S^2 = 0$	0.62
$H_1: \sigma_M^2 > 0$		$H_1: \sigma_S^2 > 0$	

US 412 PROJECT, AGGREGATE ANALYSIS - SIEVE: No. 80

23 Sublots,

2 Sample Units per Sublot,

2 Test Specimens per Sample Unit

Source of Variation	Sum of Squares	d.f.	Mean Square, M.S.	Expected M.S.
Between Sublots	33.529	22	1.524	$\sigma_T^2 + 2 \sigma_S^2 + 4 \sigma_M^2$
Between Sample Units	11.303	23	0.491	$\sigma_T^2 + 2 \sigma_S^2$
Between Tests	23.685	46	0.515	σ_T^2
Total	68.517	91		

Component	Variance		Percent of Total Variance	
	Computed	Rounded	Computed	Rounded
Material	0.2582	0.2582	33.91	33.40
Sampling	-0.0117	0.0000	-1.54	0.00
Testing	0.5149	0.5149	67.63	66.60
Total	0.7613	0.7731	100.00	100.00

Hypothesis 1	Computed F-Ratio	Hypothesis 2	Computed F-Ratio
$H_0: \sigma_M^2 = 0$	3.10	$H_0: \sigma_S^2 = 0$	0.95
$H_1: \sigma_M^2 > 0$		$H_1: \sigma_S^2 > 0$	

US 412 PROJECT, AGGREGATE ANALYSIS - SIEVE: No. 200

23 Sublots,

2 Sample Units per Sublot,

2 Test Specimens per Sample Unit

Source of Variation	Sum of Squares	d.f.	Mean Square, M.S.	Expected M.S.
Between Sublots	36.884	22	1.677	$\sigma_T^2 + 2 \sigma_S^2 + 4 \sigma_M^2$
Between Sample Units	8.259	23	0.359	$\sigma_T^2 + 2 \sigma_S^2$
Between Tests	6.658	46	0.145	σ_T^2
Total	51.801	91		

Component	Variance		Percent of Total Variance	
	Computed	Rounded	Computed	Rounded
Material	0.3294	0.3294	56.66	56.66
Sampling	0.1072	0.1072	18.44	18.44
Testing	0.1447	0.1447	24.90	24.90
Total	0.5813	0.5813	100.00	100.00

Hypothesis 1	Computed F-Ratio	Hypothesis 2	Computed F-Ratio
$H_0: \sigma_M^2 = 0$	4.67	$H_0: \sigma_S^2 = 0$	2.48
$H_1: \sigma_M^2 > 0$		$H_1: \sigma_S^2 > 0$	

VITA 2

Bedii Belgaroui

Candidate for the Degree of

Master of Science

**Thesis: COMPONENTS OF VARIABILITY IN BITUMINOUS CONCRETE
PAVEMENT CONSTRUCTION**

Major Field: Civil Engineering

Biographical:

Personal Data: Born in Tunis, Tunisia, December 2, 1966, the son of Abdallah and Fatma S. Belgaroui.

Education: Graduated from Lycee Technique de Tunis, Tunis, Tunisia, in June 1986; received Bachelor of Science Degree in Civil Engineering from Oklahoma State University in Stillwater, in December 1990; completed requirements for the Master of Science degree at Oklahoma State University in May, 1992.

Professional Experience: Research Assistant, School of Civil Engineering, Oklahoma State University, August 1991, to March 1991.